

# HONDA

## SHOP MANUAL PA50

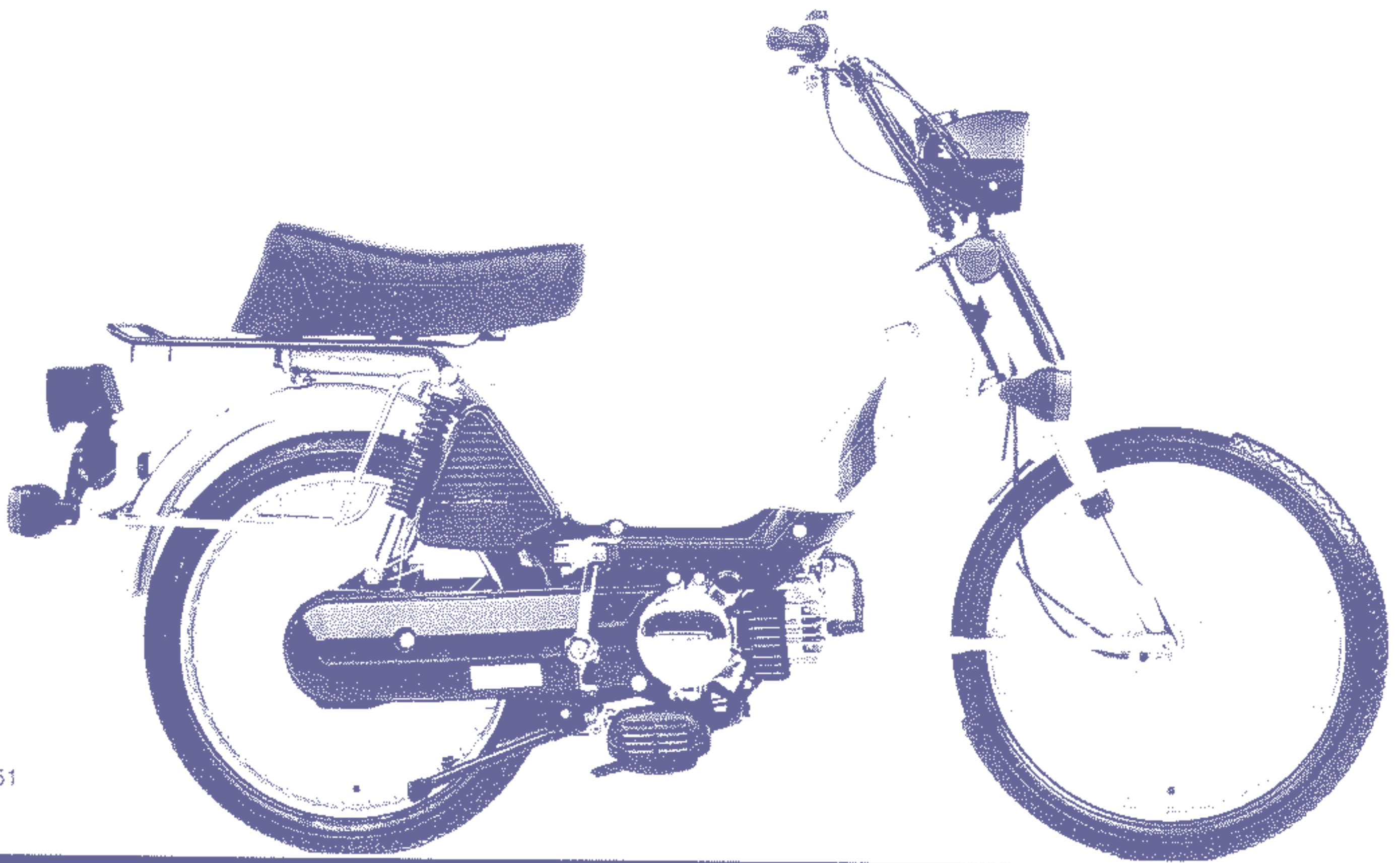

NO. HM 1051

1983

PA50



## IMPORTANT SAFETY NOTICE

**WARNING**

*Indicates a strong possibility of severe personal injury or loss of life if instructions are not followed.*

**CAUTION**

*Indicates a possibility of personal injury or equipment damage if instructions are not followed.*

**NOTE:** Gives helpful information.

Detailed descriptions of standard workshop procedures, safety principles and service operations are not included. It is important to note that this manual contains some warnings and cautions against some specific service methods which could cause **PERSONAL INJURY** to service personnel or could damage a vehicle or render it unsafe. Please understand that those warnings could not cover all conceivable ways in which service, whether or not recommended by Honda might be done or of the possible hazardous consequences of each conceivable way, nor could Honda investigate all such ways. Anyone using service procedures or tools, whether or not recommended by Honda *must satisfy himself thoroughly* that neither personal safety nor vehicle safety will be jeopardized by the service method or tools selected.



# HONDA PA50

## TABLE OF CONTENTS

|  |       |
|--|-------|
| 1. Specifications .....                    | 1     |
| 2. Technical features .....                | 2     |
| 3. Service procedures .....                | 3     |
| 4. Inspection / Adjustment .....           | 36    |
| <b>ENGINE</b>                              |       |
| 5. Engine removal/Installation .....       | 43    |
| 6. Cylinder head/cylinder piston .....     | 45    |
| 7. A.C. generator .....                    | 52    |
| 8. Drive pulley/clutch/Driven pulley ..... | 55    |
| 9. Crankshaft/crankcase .....              | 63    |
| 10. Carburetor/Air cleaner .....           | 67    |
| <b>FRAME</b>                               |       |
| 11. Handlebar/Front suspension/Front wheel | 72    |
| 12. Rear Wheel .....                       | 78    |
| 13. Final Reduction .....                  | 82    |
| 14. Fuel tank/Rear shock absorber .....    | 85    |
| 15. Electrical .....                       | 87    |
| 16. Wiring .....                           | 89-92 |

# 1. SPECIFICATIONS

| ITEM  | DX    | S      | Custom  | St.     |
|---|-------|--------|---|---------|
| Overall height  | 1050  | 993    | 1120  | 985     |
| Overall length  | 1650  | 1650   | 1650  | 1650    |
| Overall width   | 640   | 620    | 715   | 620     |
| Wheel base  | 1055  | 1055   | 1055  | 1055    |
| Ground clearance  | 100   | 100    | 100   | 100     |
| Dry weight  | 54 kg | 50,8kg | 59,7 kg   | 49,6 kg |
| FRAME<br>F. suspension travel<br>R. suspension travel<br>F. tire size<br>R. tire size<br>Fuel capacity<br>Fuel reserve<br>Caster angle<br>Trail   |       |        | Back-Bone<br>Telescopic<br>Swing unit<br>2.00 - 2.25 - 17 - 2PR<br>2.00 - 2.25 - 17 - 2PR<br>3 l<br>0,6 l<br>66° 30'<br>55 mm   |         |
| ENGINE<br>Bore and stroke<br>Displacement<br>Compression ratio<br><br>Carburator<br>Max. power<br><br>Max. torque<br><br>Fuel<br><br>Idling speed |       |        | Air cooled 2 stroke<br>40.0 x 39.6<br>49 cc<br>6,7 : 1 (40 - 45 km/h)<br>7,0 : 1 (NL - 25 km/h)<br>ø 12<br>1,69 Kw/5500 (45 km/h)<br>1,32 Kw/5000 (40 km/h)<br>1,10 Kw/3800 (NL - 25 km/h)<br>3,72 Nm/3500 (45 km/h)<br>3,60 Nm/2400 (NL)<br>3,30 Nm/3000 (40 km/h)<br>3,05 Nm/3000 (25 km/h)<br>Mixed fuel/oil<br>1/25 - 40 - 45 km/h<br>1/50 - NL - 25 km/h<br>1500 RPM |         |
| DRIVE TRAIN<br>Clutch<br>Transmission<br>Transmission ratio<br><br>Final ratio  |       |        | Drive belt<br>Autom. centrif. dry type<br>Variable pulley or fixed transmission<br>1.80 ~ 0.98 (45 km/h)<br>1.80 ~ 1.12 (40 km/h)<br>1.80 ~ 1.46 (25 km/h)<br>2.149 ~ 1.131 (NL)<br>1.129 ~ for fixed transmission<br>12.462  |         |
| ELECTRICAL<br>Battery<br><br>Generator<br>Tail/stop<br>Turn signal  |       |        | Flywheel magneto<br>6 V - 0.8 AH<br>6 V - 6 W France<br>6 V - 18 W UK<br>6 V - 15 W other<br>44 W/4800<br>6 V - 4/5 W<br>6 V - 21 W Germany<br>6 V - 10 W other   |         |
| Tire pressure   |       |        | Front: 2.00-2.50 kg/cm <sup>2</sup><br>Rear: 2.00-2.50 kg/cm <sup>2</sup>   |         |



# HONDA PA50

## 2. TECHNICAL FEATURES HONDA V-MATIC

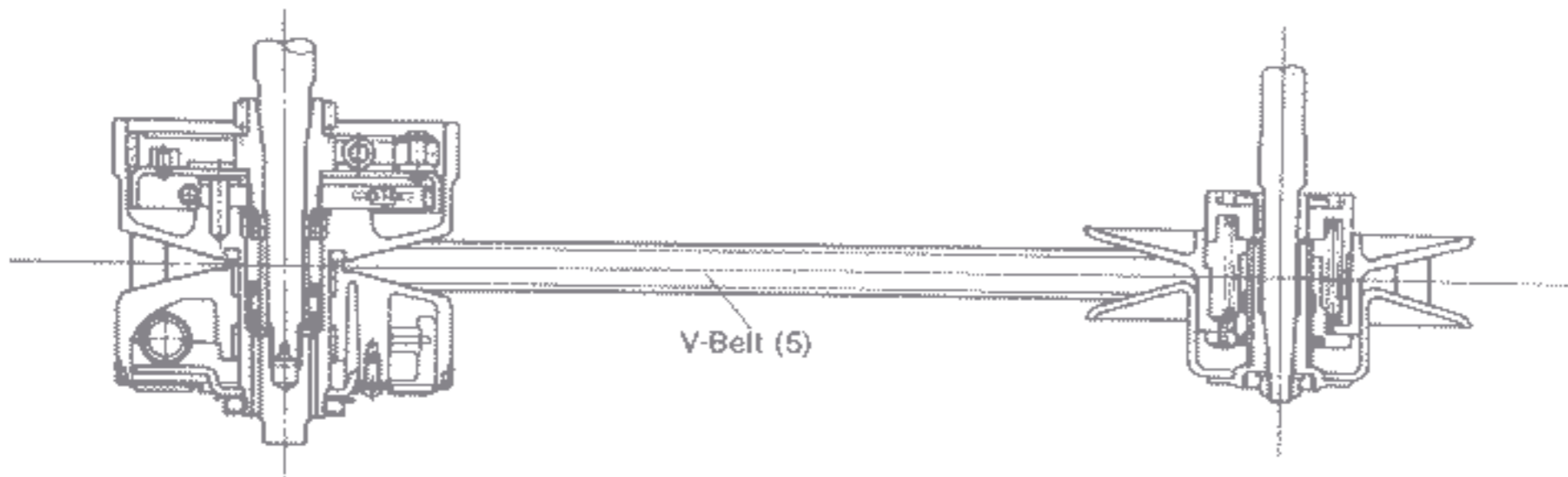
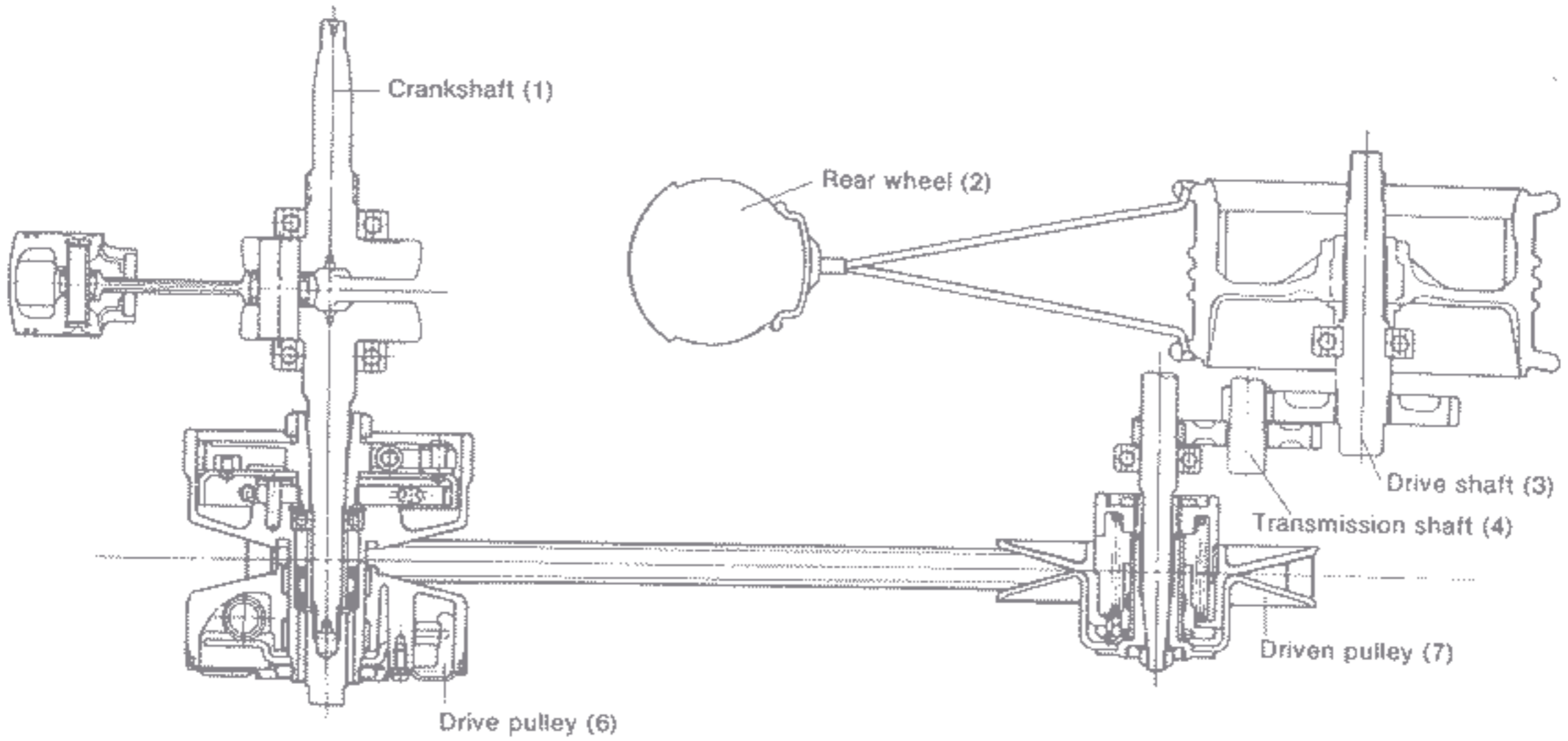

Drive pulley (1)

Driven pulley (2)

Drive pulley

Driven pulley

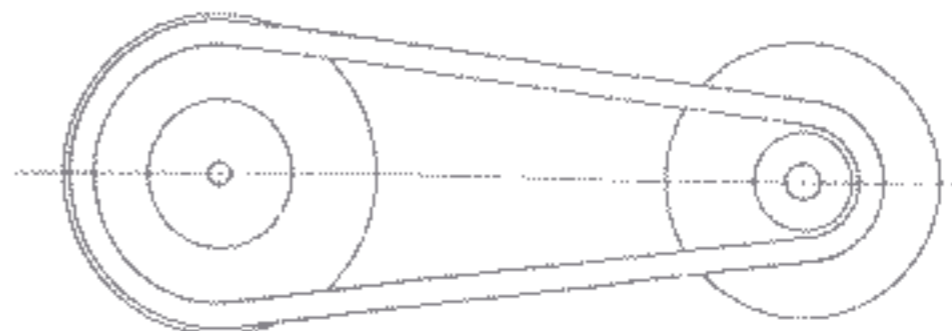
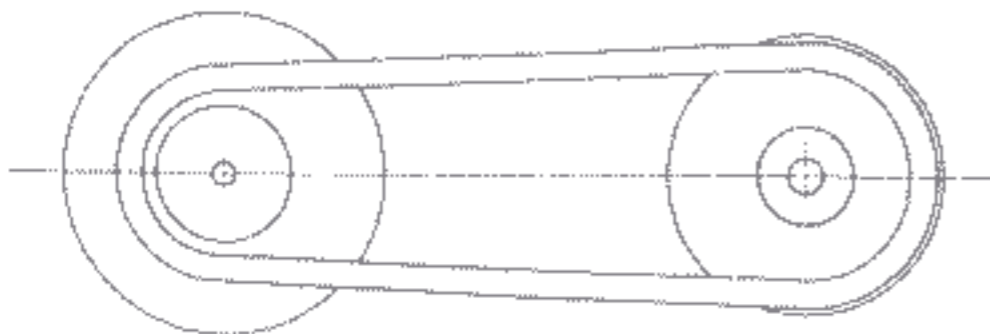



# HONDA<sup>®</sup> PA50

## 3. SERVICE PROCEDURES

|                                |       |
|--------------------------------|-------|
| 1. Service data .....          | 4     |
| 2. Torque specifications ..... | 5     |
| 3. Special tools .....         | 6     |
| 4. Lubrication .....           | 7     |
| 5. Wiring diagram .....        | 8-28  |
| 6. Trouble shooting .....      | 29-34 |
| 7. Maintenance schedule .....  | 35    |

## 1. Service data

(Engine)

Unit: mm

| Item  | Assembly Standard             | Repair Limit       | Page          |     |
|---|-------------------------------|--------------------|---------------|-----|
| Piston-to-piston ring clearance               | 0.025-0.055 (0.001-0.002)     | 0.1 (0.0039)       | 94            |     |
| Piston skirt O.D. (4mm from bottom)           | 39.955-39.975 (1.573-1.574)   | 39.85 (1.569)      | 94            |     |
| Cylinder I.D.                                 | 40.00-40.020 (1.5748-1.5752)  | 40.05 (1.5767)     | 92            |     |
| Piston ring end gap                           | 0.15-0.35 (0.0059-0.138)      | 0.6 (0.024)        | 96            |     |
| Piston pin O.D.                               | 9.994-10.000 (0.395-0.3937)   | 9.97 (0.3925)      | 96            |     |
| Piston pin hole I.D.                          | 10.002-10.008 (0.3938-0.3940) | 10.03 (0.3949)     | 96            |     |
| Starting clutch lining thickness              | 2.9-3.1 (0.1142-1.220)        | 1.5 (0.0591)       | 118           |     |
| Drive clutch lining thickness                 | 3.4-3.6 (0.1339-1.417)        | 2.0 (0.0787)       | 118           |     |
| Starting clutch face (Drive face) I.D.        | 96.9-97.1 (3.8149-3.8228)     | 97.5 (3.8386)      | 118           |     |
| Clutch weight face (Drive face) I.D.          | 104.0-104.1 (4.0945-4.0984)   | 104.5 (4.1142)     | 118           |     |
| Connecting rod big end bearing side clearance | 0.15-0.41 (0.0059-0.0161)     | 0.6 (0.0236)       | 128           |     |
| Crankshaft runout                             | Left 60mm                     | 0.05 max. (0.0020) | 0.15 (0.0059) | 128 |
|   | Right 75mm                    | 0.05 max. (0.0020) | 0.15 (0.0059) |     |

(Frame)

| Item                                    | Assembly Standard       | Repair Limit | Page |
|---|-------------------------|--------------|------|
| Front wheel axle bend                   | 0.05 max (0.002)        | 0.1 (0.004)  | -    |
| Front and rear wheel hub I.D.           | 80.0-80.2 (3.150-3.157) | 81.0 (3.189) | 146  |
| Front and rear brake lining thicknesses | 3.5 (0.138)             | 2.0 (0.079)  | 146  |
| Front wheel runout                      | 1.0 max (0.039)         | 2.0 (0.079)  | 146  |



## 2. Torque specifications

(Engine)

| Ref.No | Tightening point                      | Qty | Thread dia<br>mm | Torque  |             | Page |
|--------|---------------------------------------|-----|------------------|---------|-------------|------|
|        |                                       |     |                  | kg-cm   | (lbs-ft)    |      |
| 1      | Cylinder head hold-down               | 4   | 6                | 90-120  | (5.8-8.7)   | 88   |
| 2      | A.C. flywheel generator attaching nut | 1   | 10               | 300-400 | (21.7-28.9) | 100  |
| 3      | Drive pulley attaching nut            | 1   | 10               | 300-400 | (21.7-28.9) | 108  |
| 4      | Driven pulley attaching nut           | 1   | 8                | 200-250 | (14.5-18.1) | 108  |
| 5      | Intake pipe attaching nuts            | 4   | 6                | 80-120  | (5.8-8.7)   | -    |
| 6      | Nut special 27 mm                     | 1   | 27               | 280-350 | (20.3-25.3) | -    |
| 7      | Nut special 20 mm                     | 1   | 20               | 500     | (36.0)      | -    |
| 8      | Engine Hanger Bolt                    | 1   | 10               | 590-650 | (42.6-47.0) | 82   |

(Frame)

| Ref.No | Tightening point          | Qty | Thread dia<br>mm | Torque  |             | Page |
|--------|---------------------------|-----|------------------|---------|-------------|------|
|        |                           |     |                  | kg-cm   | (lbs-ft)    |      |
| 1      | Suspension bar Cap Nut    | 2   | 10               | 400-500 | (28.9-36.1) | -    |
| 2      | Steering stem nut         | 1   | 22               | 250-350 | (18.1-25.3) | -    |
| 3      | Steering top bridge bolts | 2   | 10               | 300-400 | (21.7-28.9) | -    |
| 4      | Steering holder bolts     | 4   | 6                | 90-120  | (6.5-8.7)   | -    |
| 5      | Front wheel axle nuts     | 2   | 11               | 300-400 | (21.7-28.9) | -    |
| 6      | Free wheel guide          | 1   | 14               | 400-600 | (28.9-43.4) | -    |
| 7      | Rear shock absorber bolts | 4   | 8                | 300-400 | (21.7-28.9) | -    |

## Standard torque specifications

| Type        | Torque  |             |
|-------------|---------|-------------|
|             | kg-cm   | (lbs-ft)    |
| 5 mm bolts  | 40- 70  | (2.9-5.1)   |
| 6 mm screws | 80-120  | (5.8-8.7)   |
| 6 mm bolts  | 80-120  | (5.8-8.7)   |
| 8 mm bolts  | 200-250 | (14.5-18.1) |
| 10 mm bolts | 300-400 | (21.7-28.9) |
| 14 mm nut   | 600-800 | (43.4-57.8) |

**3. Special tools**

| N° | Tool parts no | Description                |
|----|---------------|----------------------------|
| 1  | 07902-1480000 | Holder, drive pulley       |
| 2  | 07916-1480001 | Wrench, lock nut 36 x 46   |
| 3  | 07925-0010001 | Holder, flywheel           |
| 4  | 07933-1480000 | Puller, drive pulley       |
| 5  | 07935-1480000 | Puller, case               |
| 6  | 07965-1480001 | Assembly tool, seal & case |
| 7  | 07934-1480000 | Cam Puller                 |
| 8  | 07797-0010400 | Case, special Tools        |
| 9  | 07933-1480100 | Puller pulley              |
| 10 | 07960-1480100 | Assy, driven pulley        |
| 11 | 07900-1480002 | Tool Set                   |

**Common tools**

| No | Tool parts no | Description                 |
|----|---------------|-----------------------------|
| 1  | 07959-3290000 | Rear shock disassembly tool |
| 2  | 07401-0010000 | Float level gauge           |
| 3  | 07902-2000000 | Pin spanner wrench          |



# HONDA PA50

## 4. Lubrication

### ● ENGINE

| Point of lubrication |  | Lubricant                   |
|----------------------|--|-----------------------------|
| 1                    | Crankcase rotating or sliding surfaces | Use Honda oil or equivalent |
| 2                    | Cylinder rotating or sliding surfaces  | Use Honda oil or equivalent |
| 3                    | Oil felt                               | Engine oil (ultra oil)      |
| 4                    | Weight rollers of movable drive face   | Grease                      |
| 5                    | Driven pulley spring                   | Grease                      |

### ● FRAME

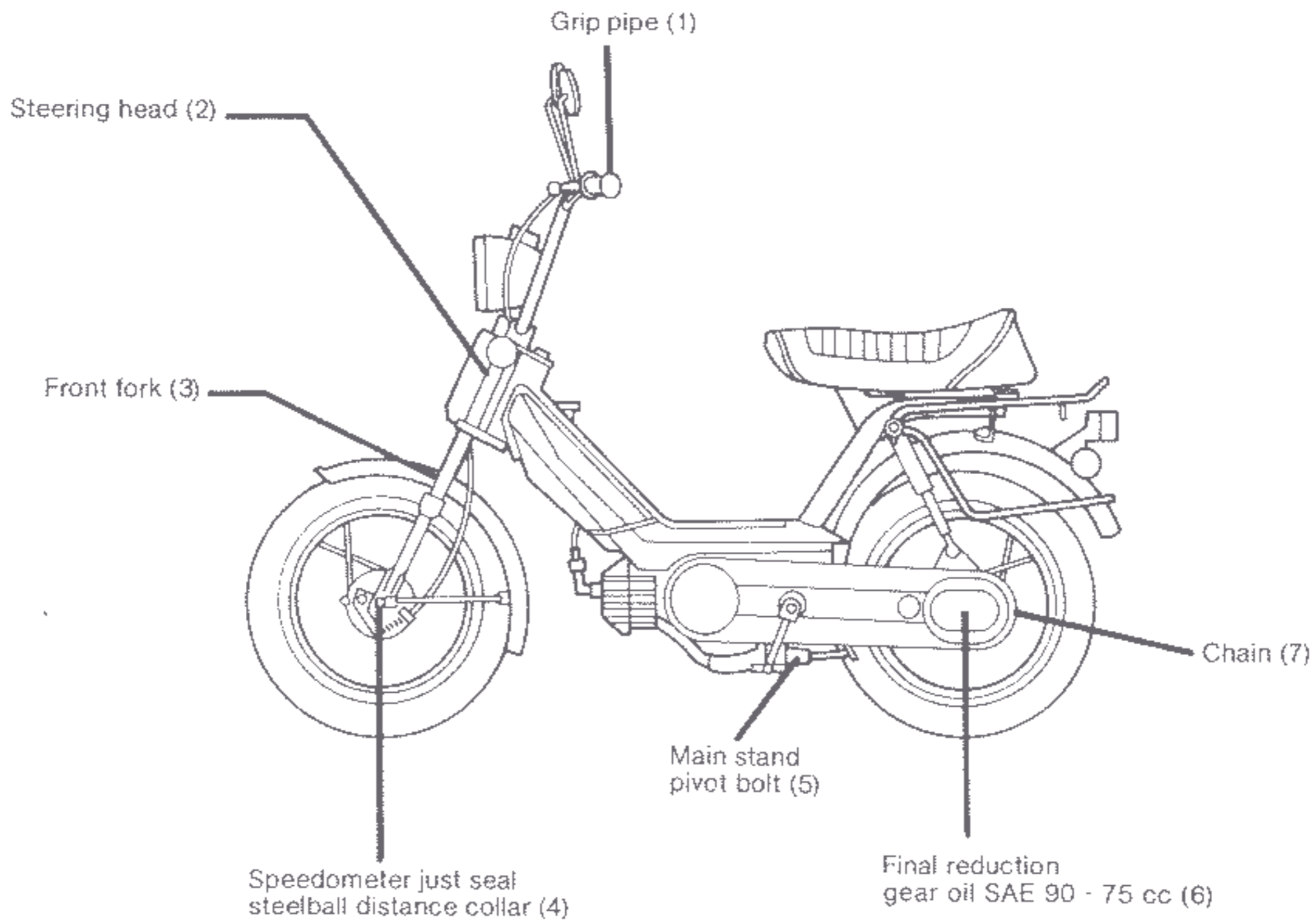



# HONDA PA50

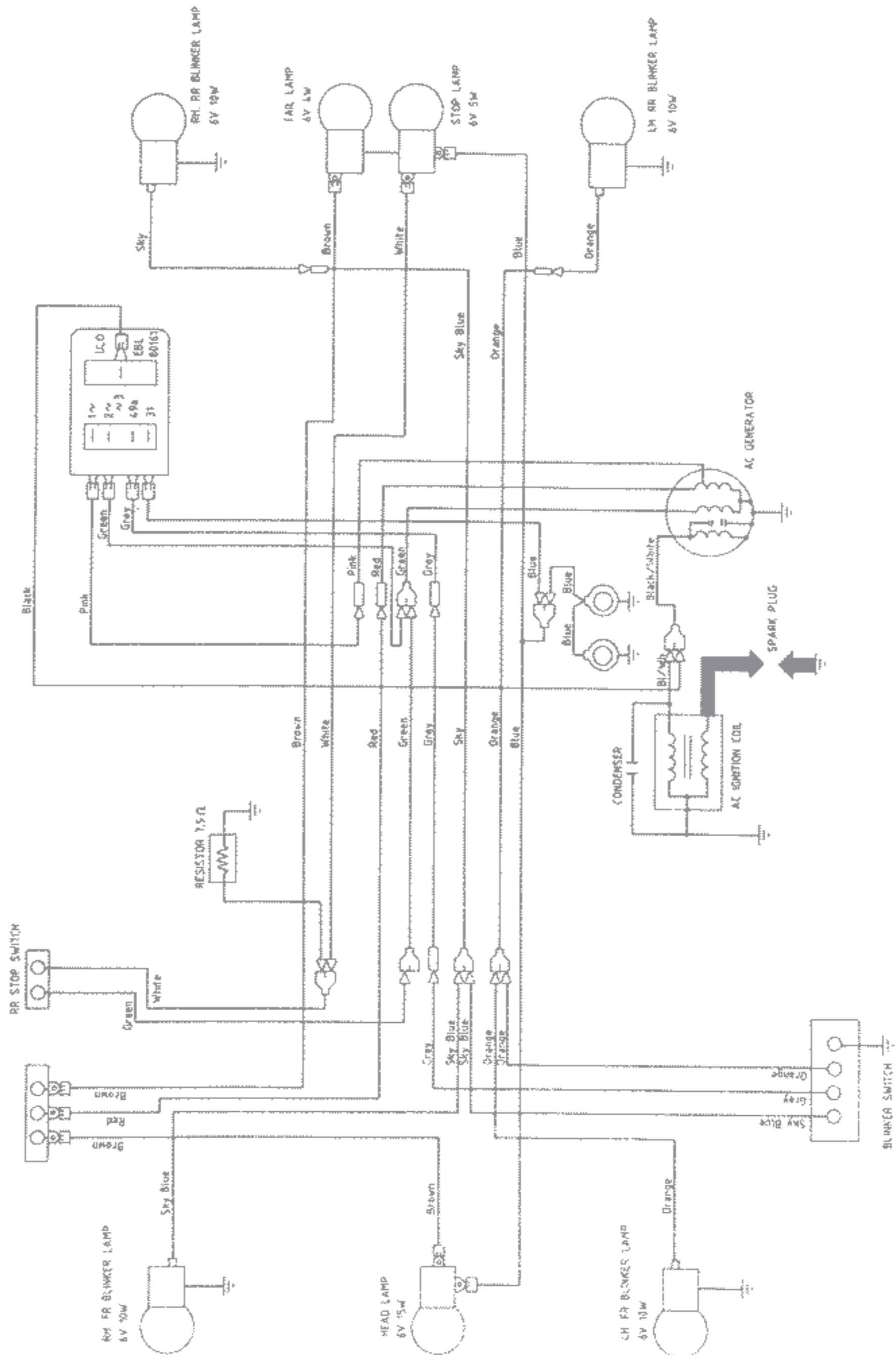

DESTINATION : MVLC  
VLCB

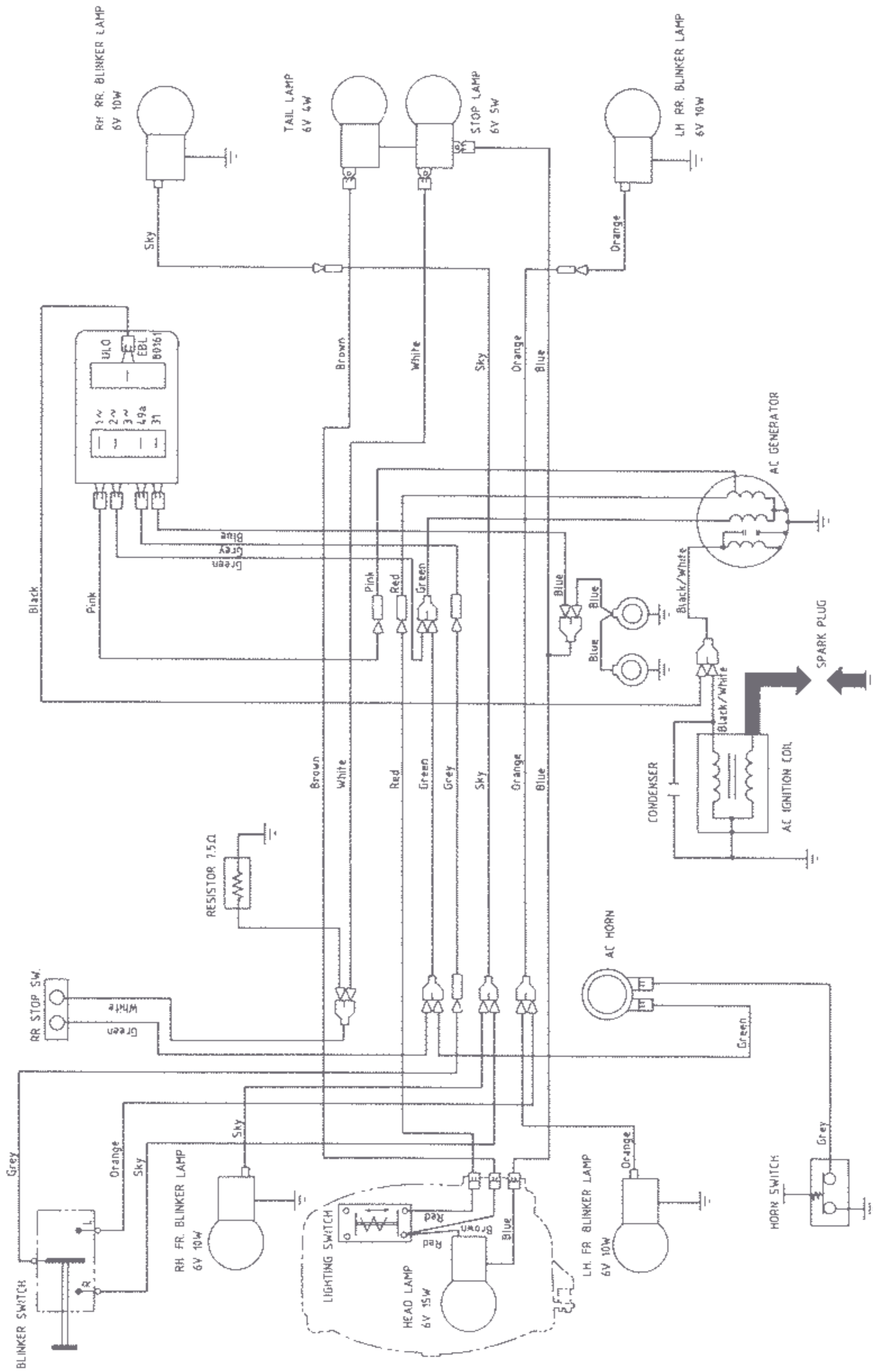

DESTINATION : C VLCS : B  
MC VLCS : B



# HONDA PA50

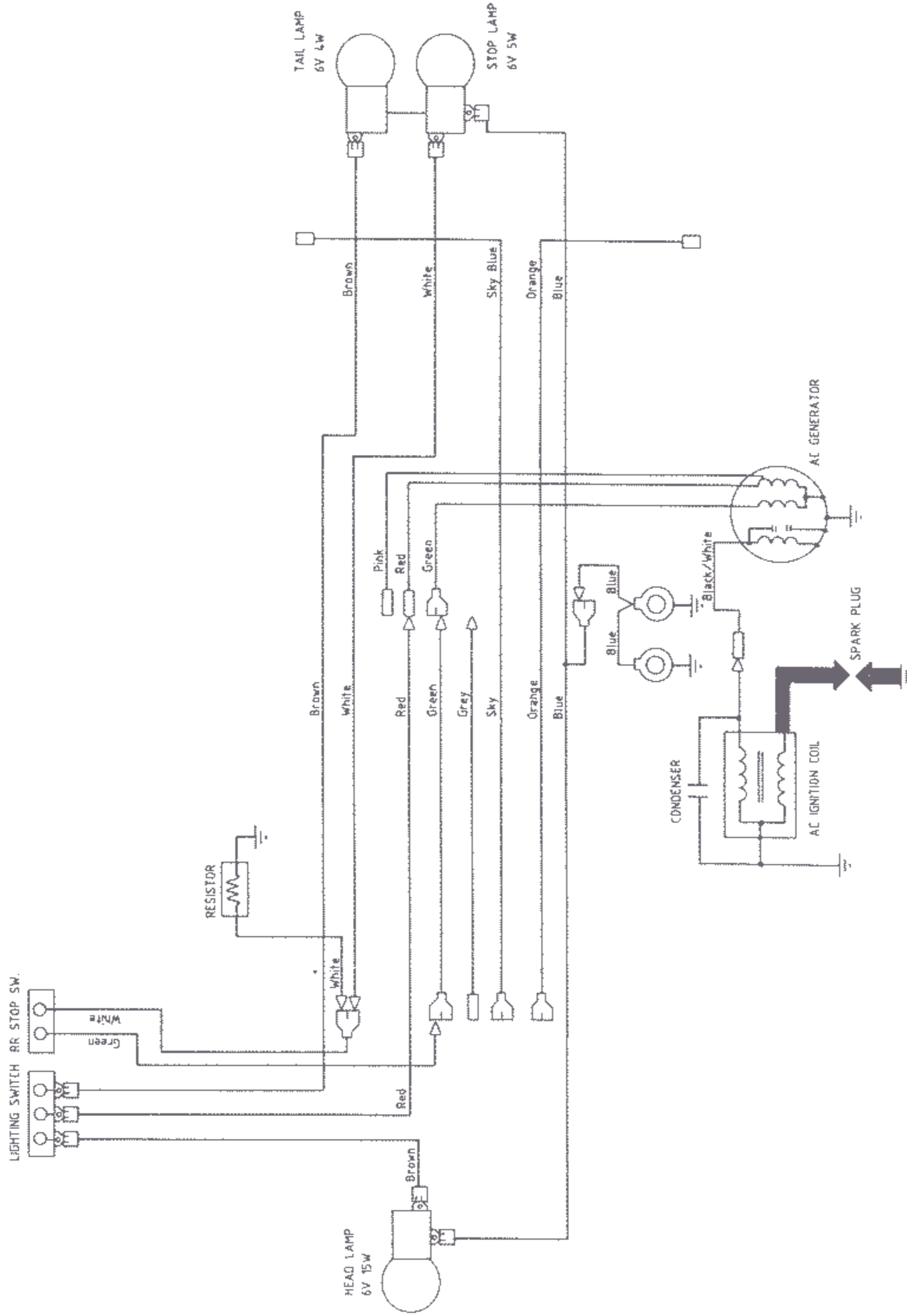

DESTINATION : B-L-VL  
 B-ML-MVL  
 DK-VL&S VL  
 AUS

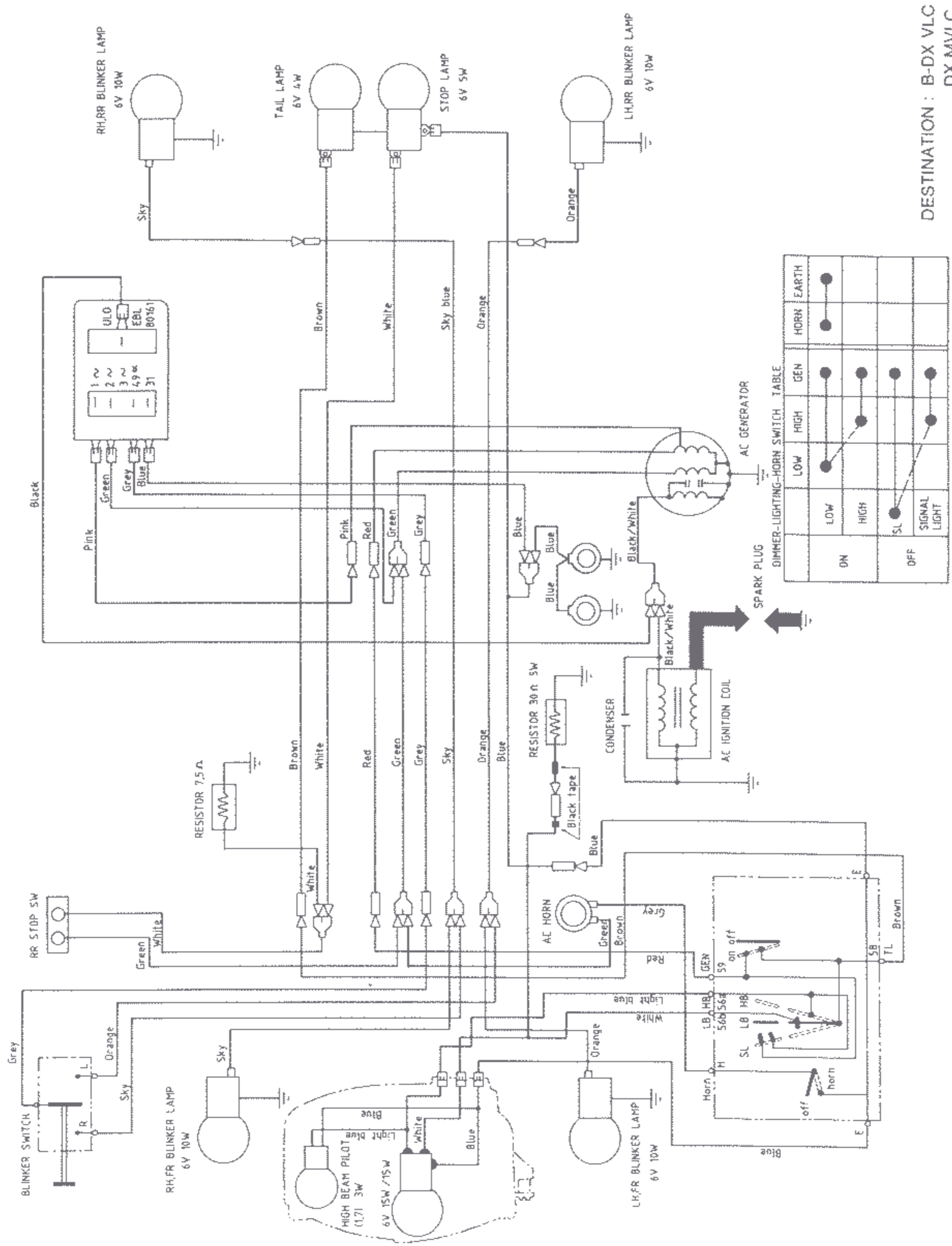

DESTINATION : B-DX VLC  
DX MVLC  
S VLCS  
S MVLCS

|     | LOW | HIGH | GEN | HORN | EARTH |
|-----|-----|------|-----|------|-------|
| DN  | ●   | ●    | ●   | ●    | ●     |
| OFF | ●   | ●    | ●   | ●    | ●     |



# HONDA PA50

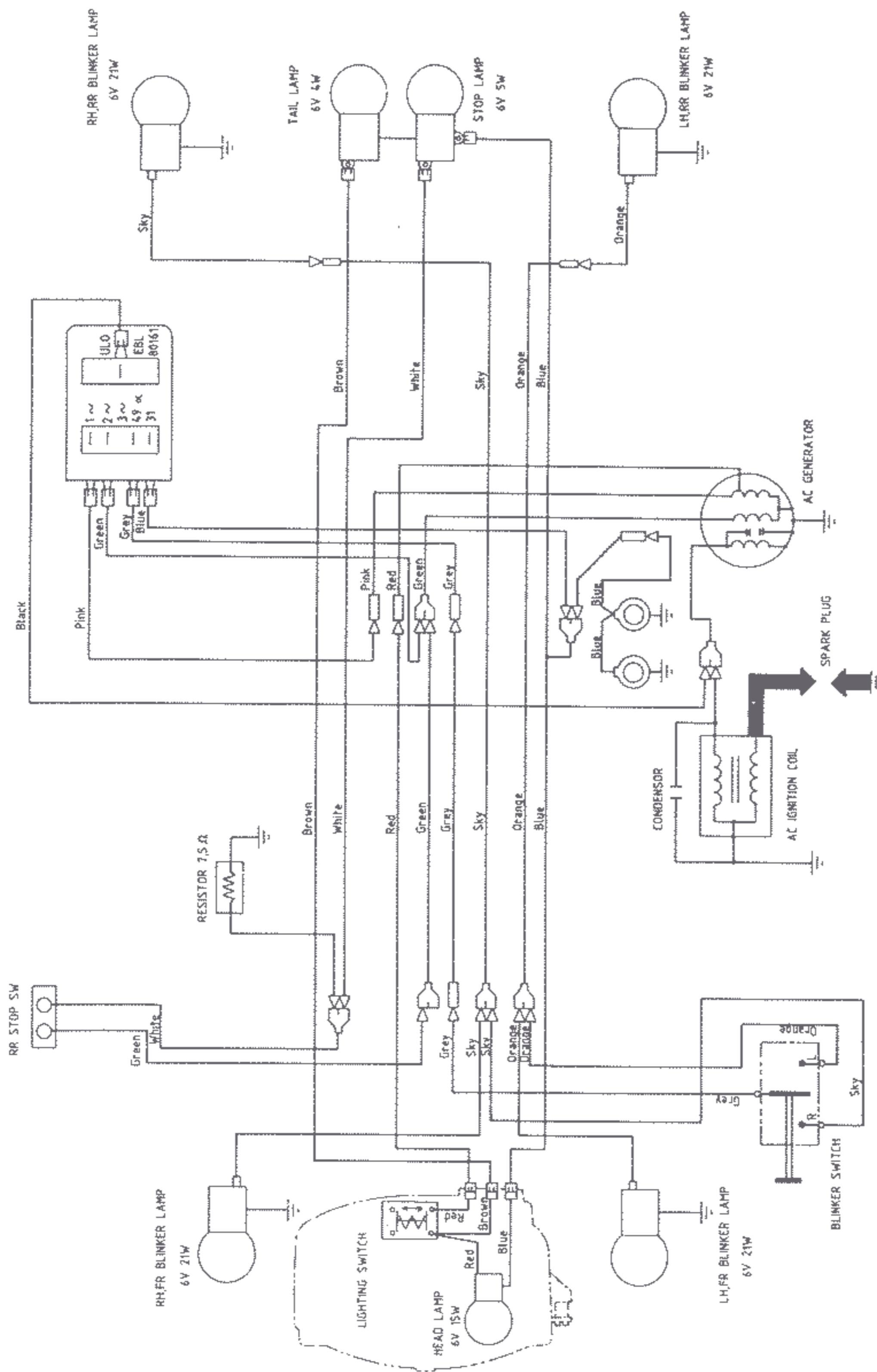

DESTINATION : G



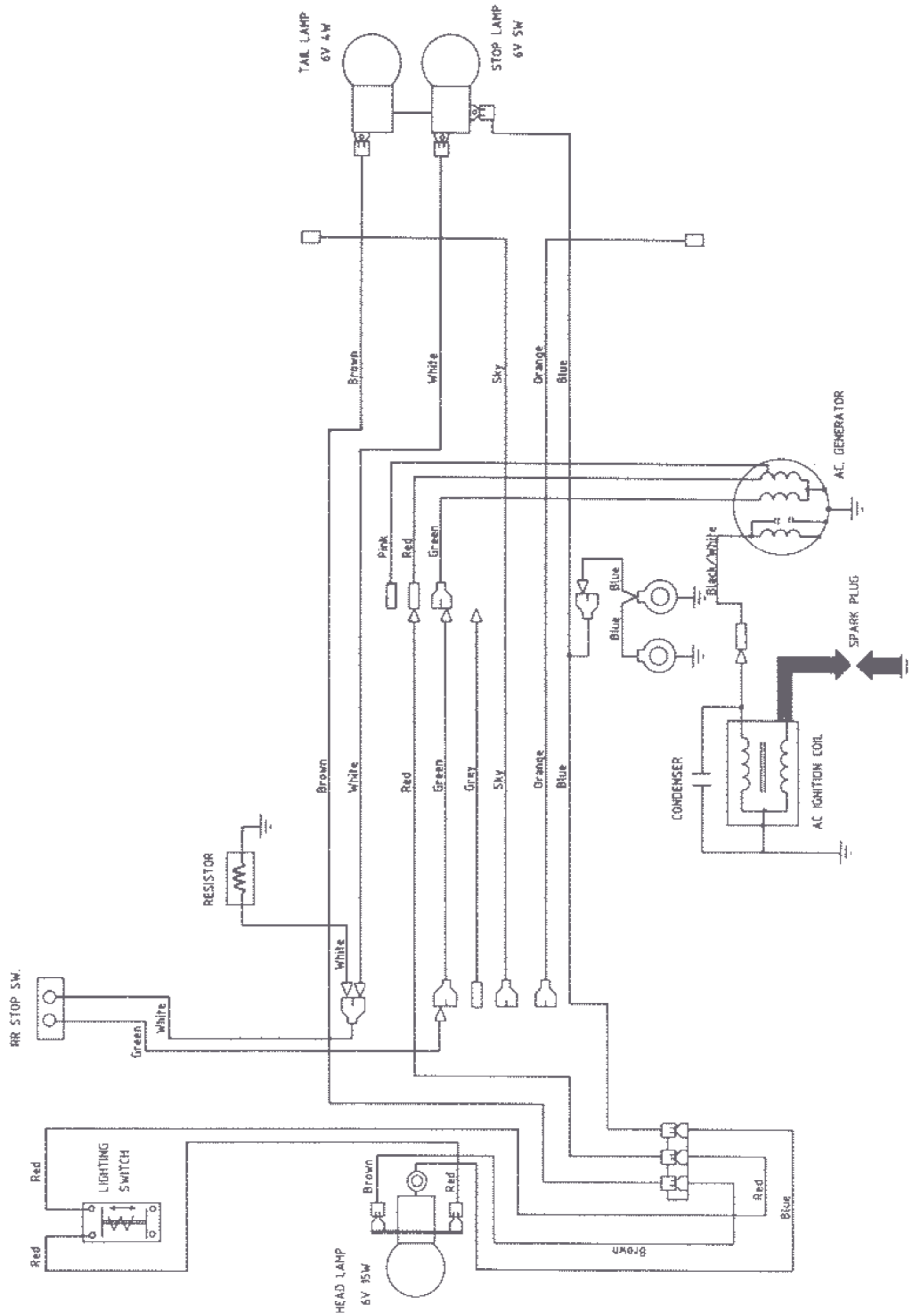

DESTINATION : DX MVLS : G  
S MVLS : G  
SVLS : A



# HONDA PA50

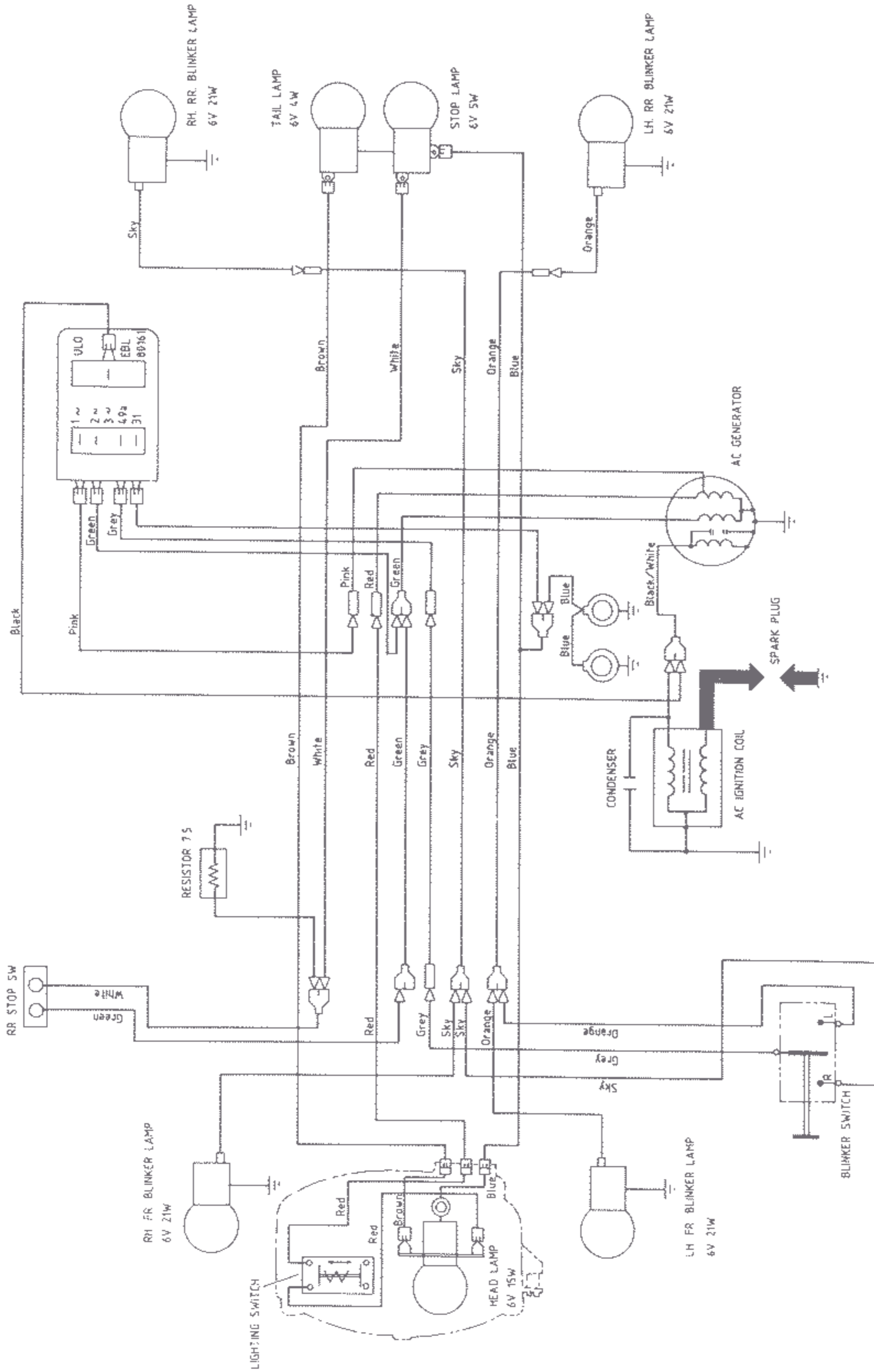

DESTINATION : GERM.  
MS VLCS  
MS LCS

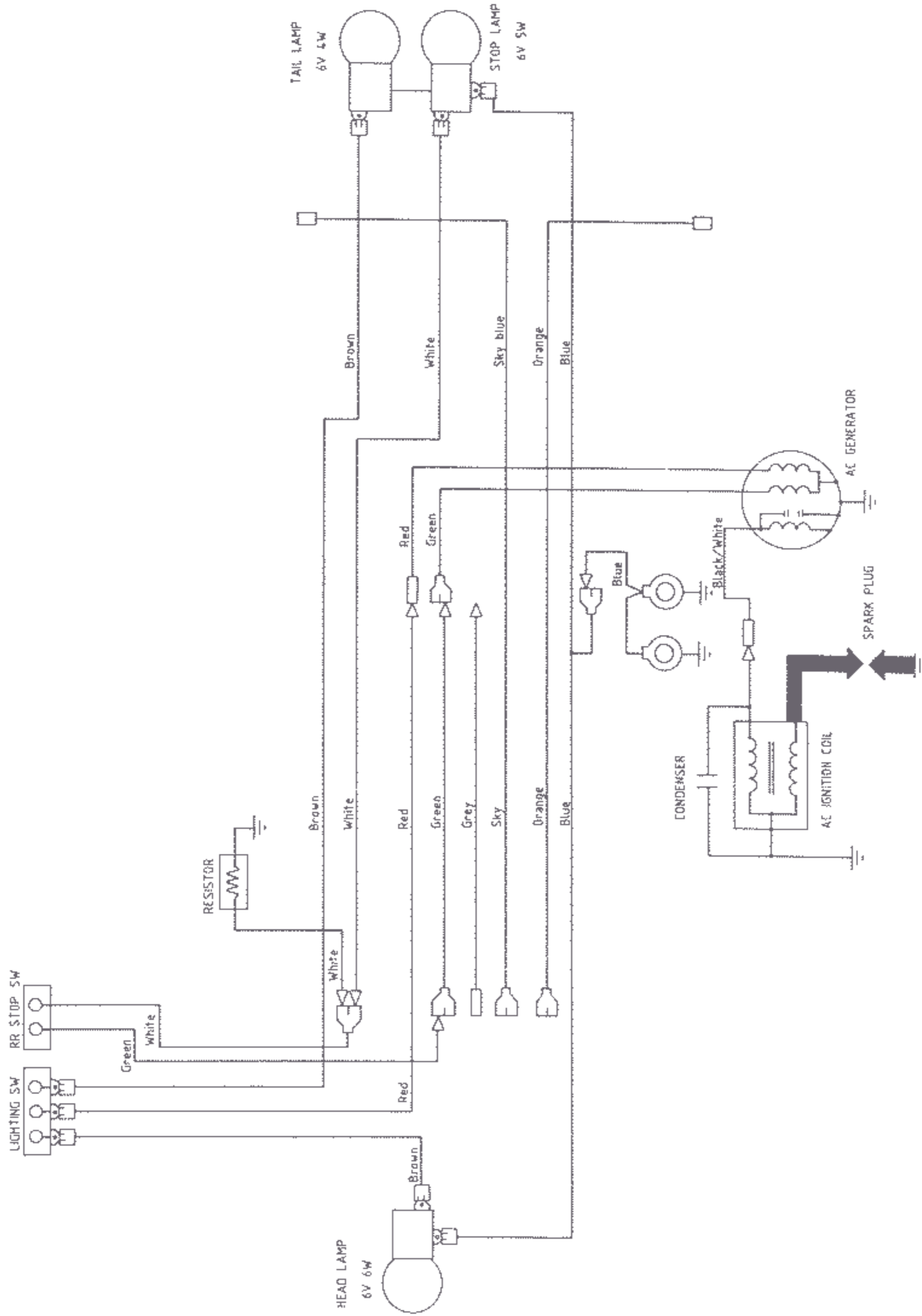

DESTINATION : VL : F  
VL : GR



# HONDA PA50

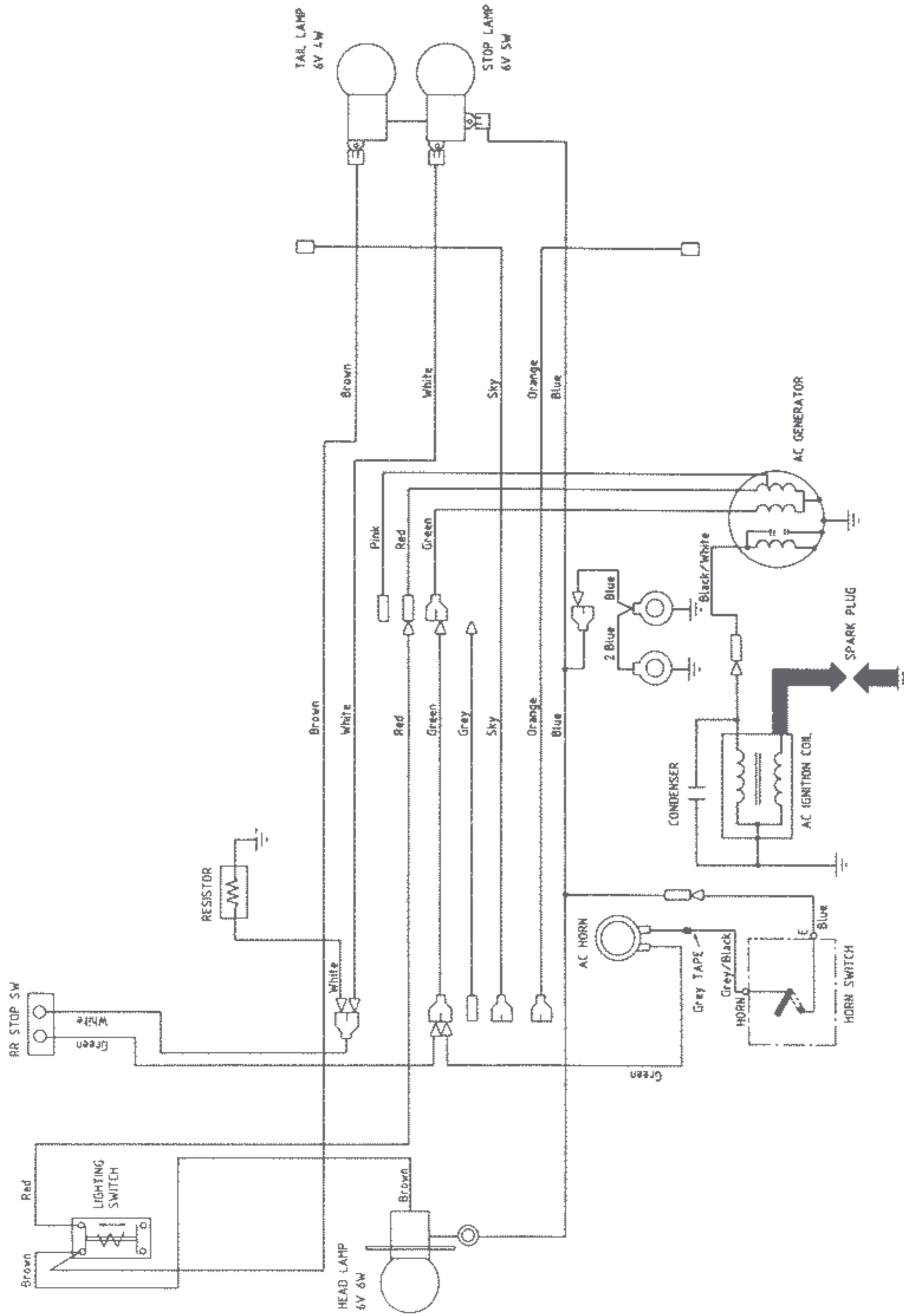

DESTINATION : DX - VL : F  
S VLS : N

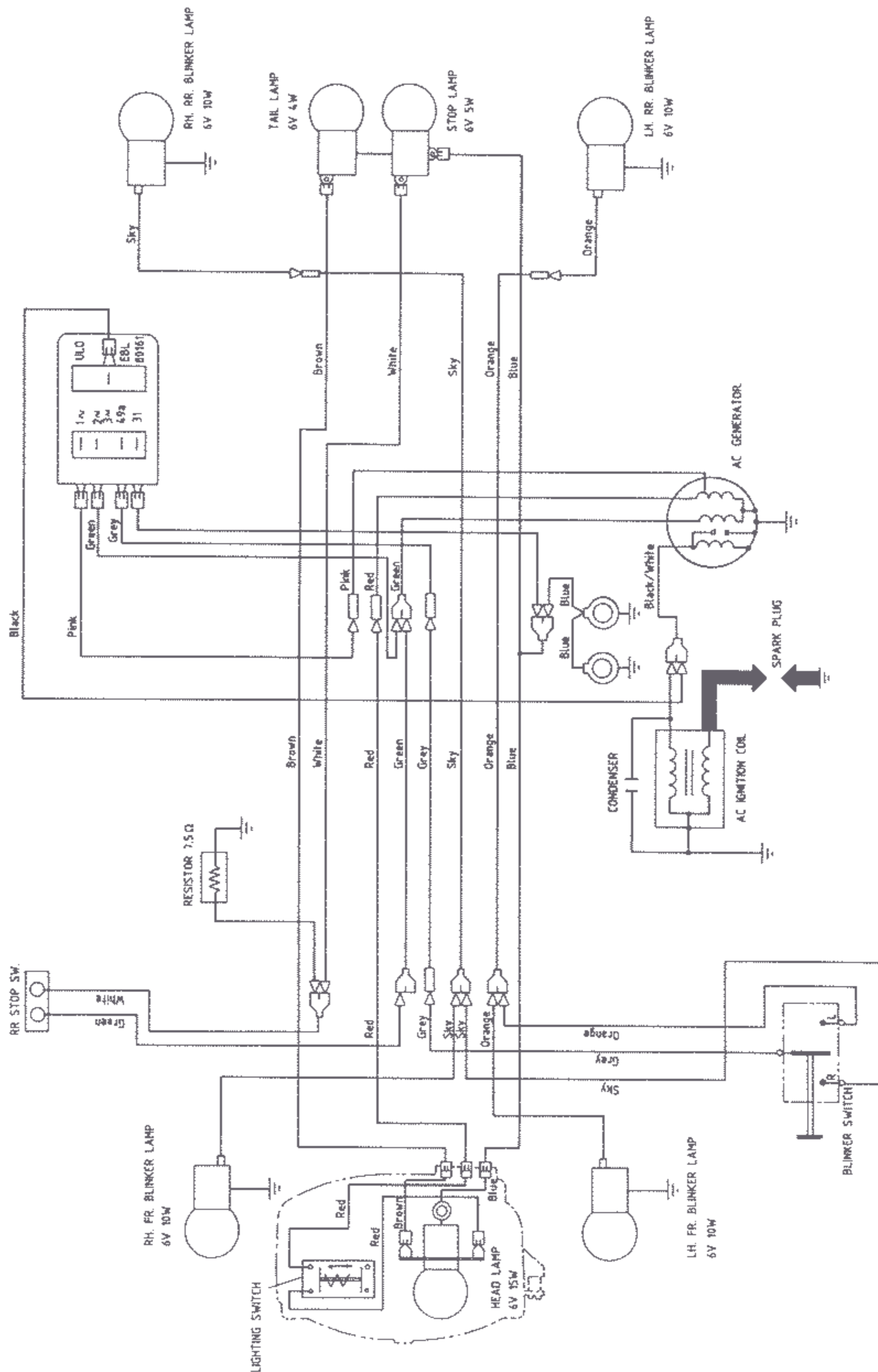

DESTINATION : NL DX VLC



# HONDA PA50

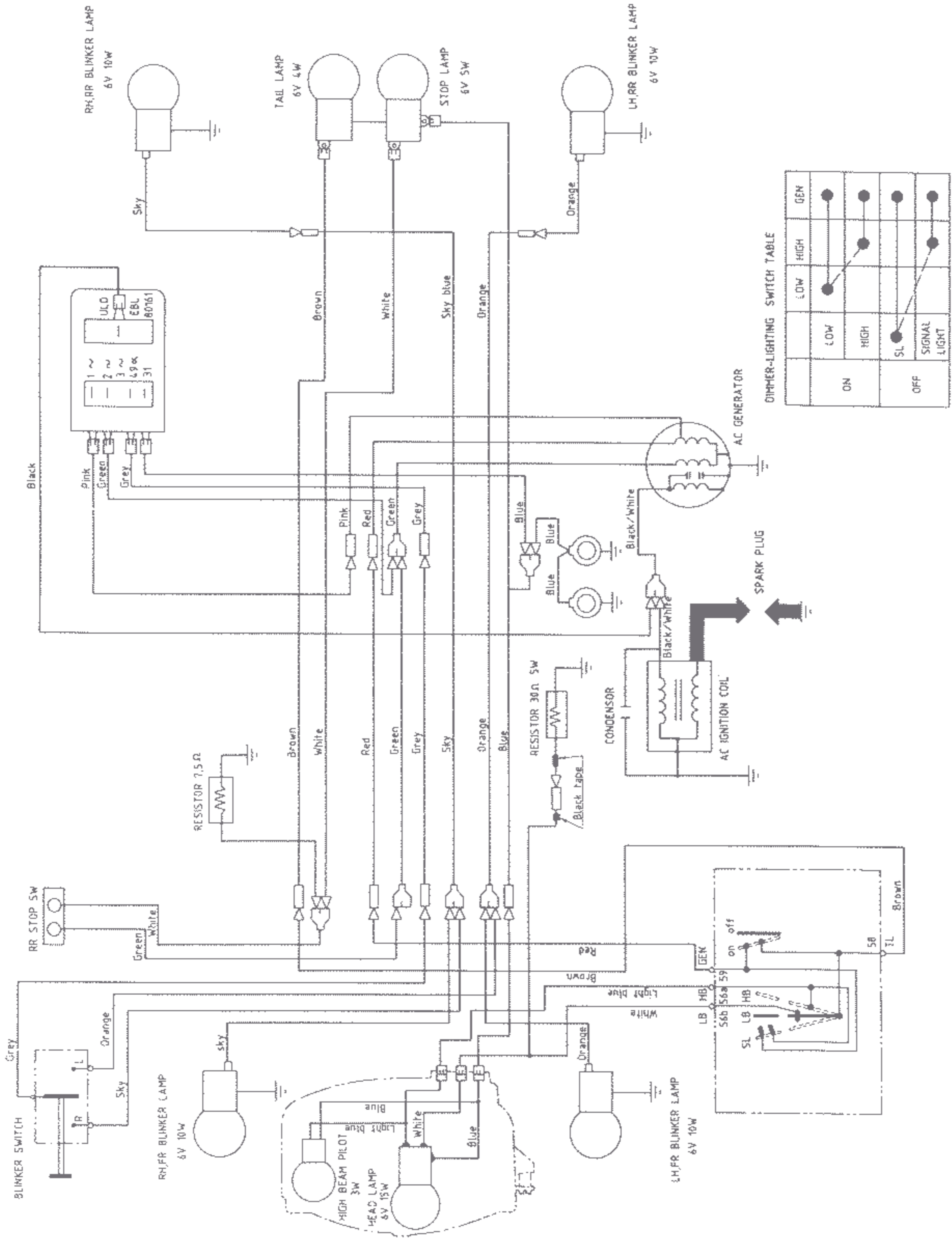

DESTINATION : SVLCS NL

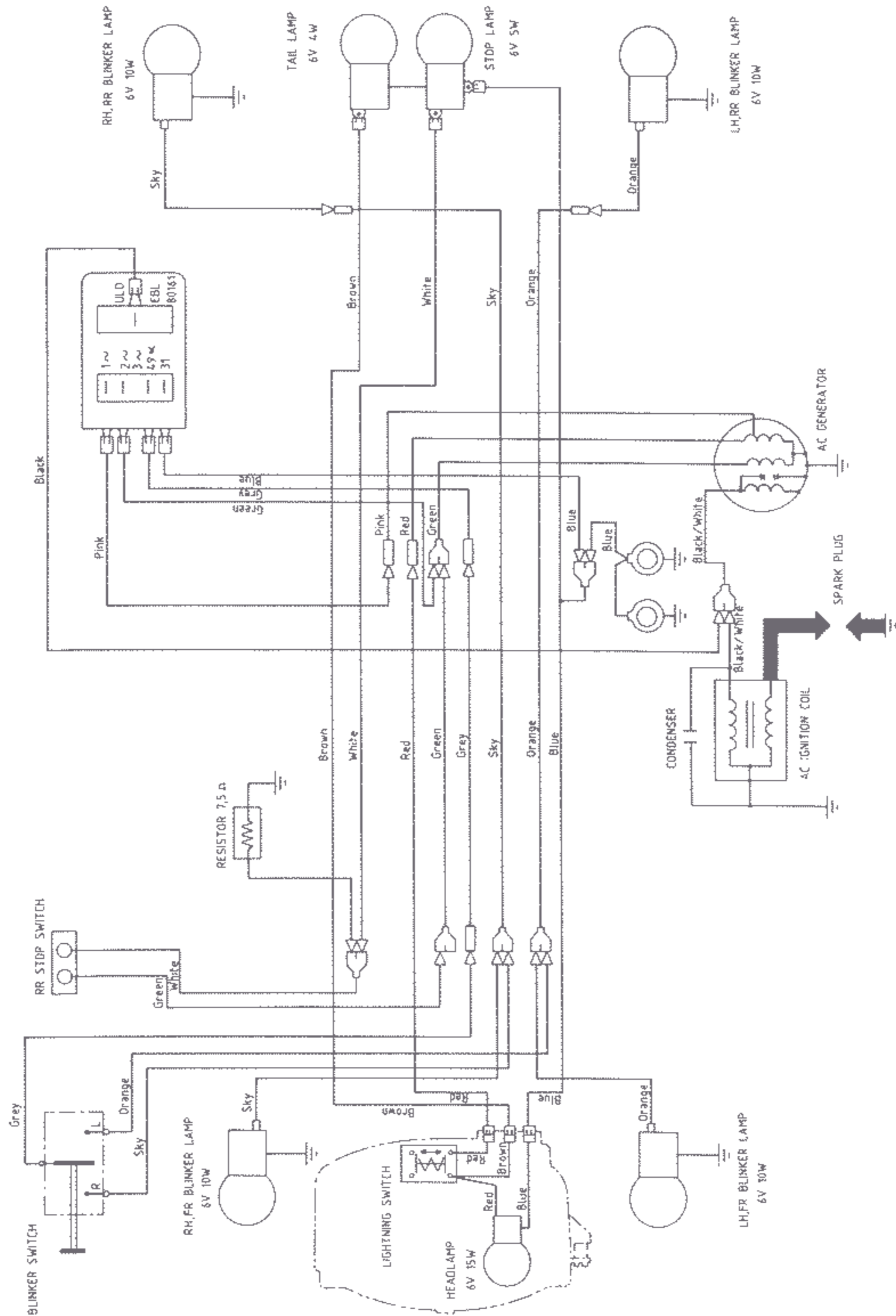

DESTINATION : NL



# HONDA PA50

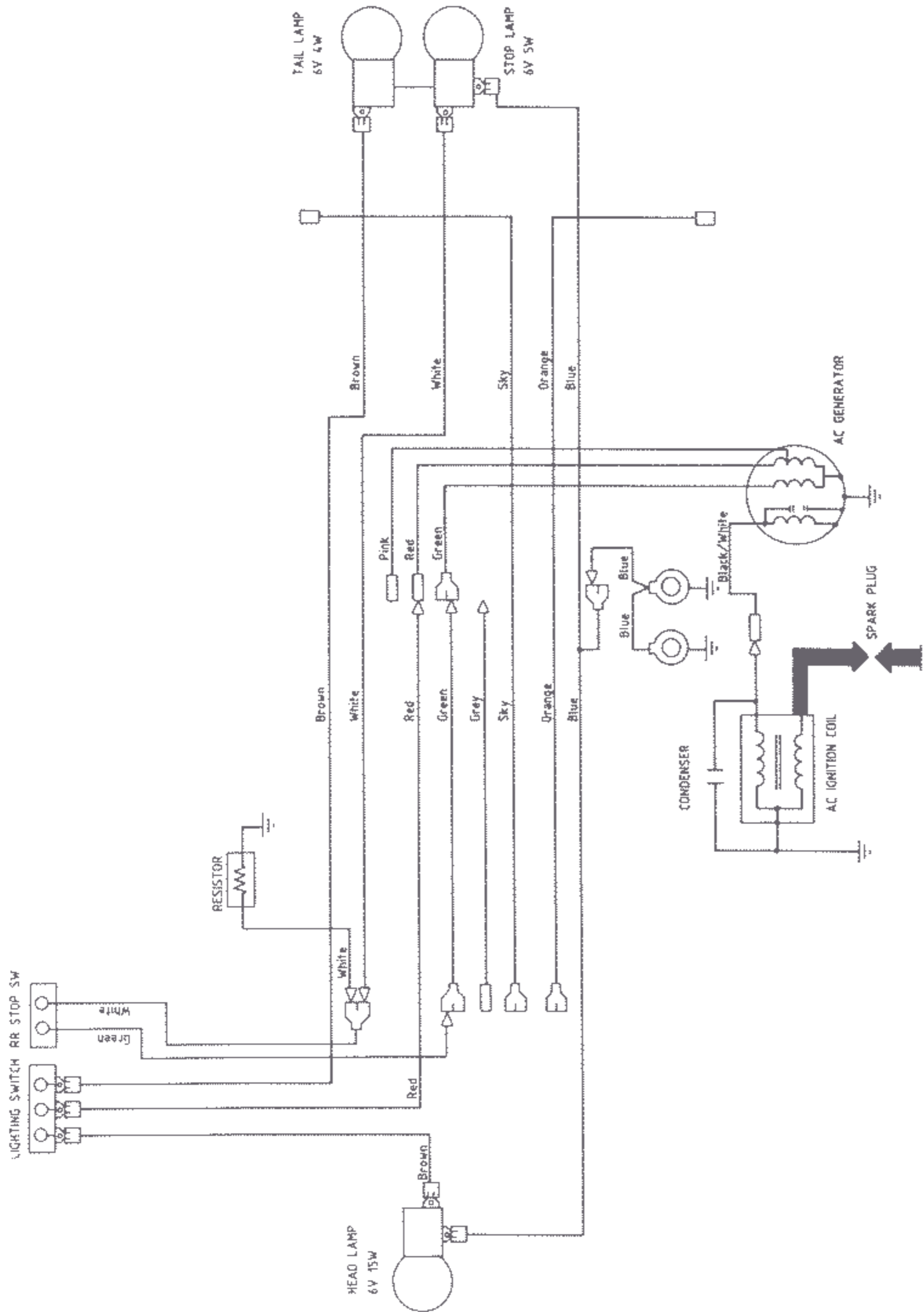

DESTINATION : ML : D  
VL : NL



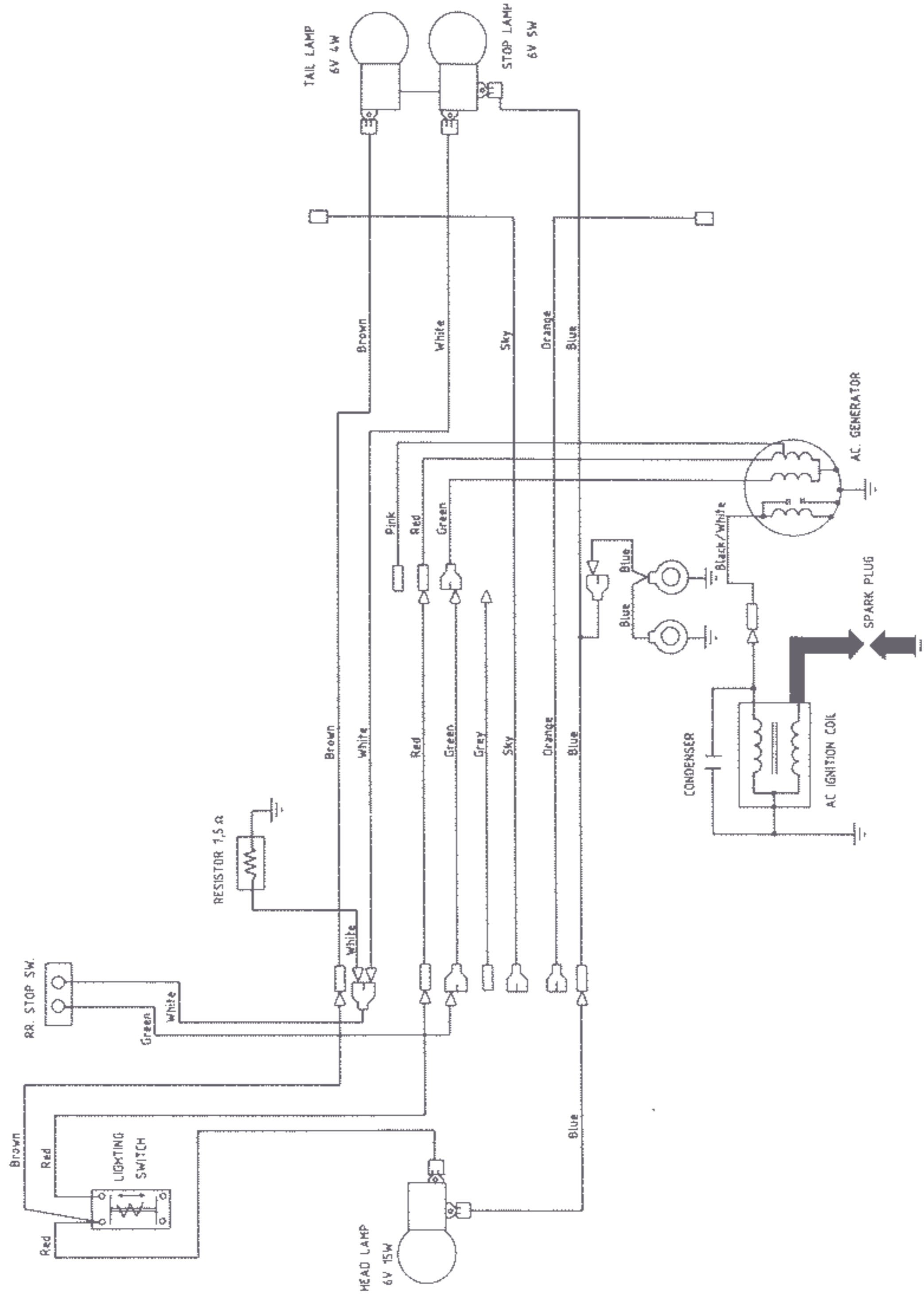

DESTINATION : SVLS-AUS



# HONDA PA50

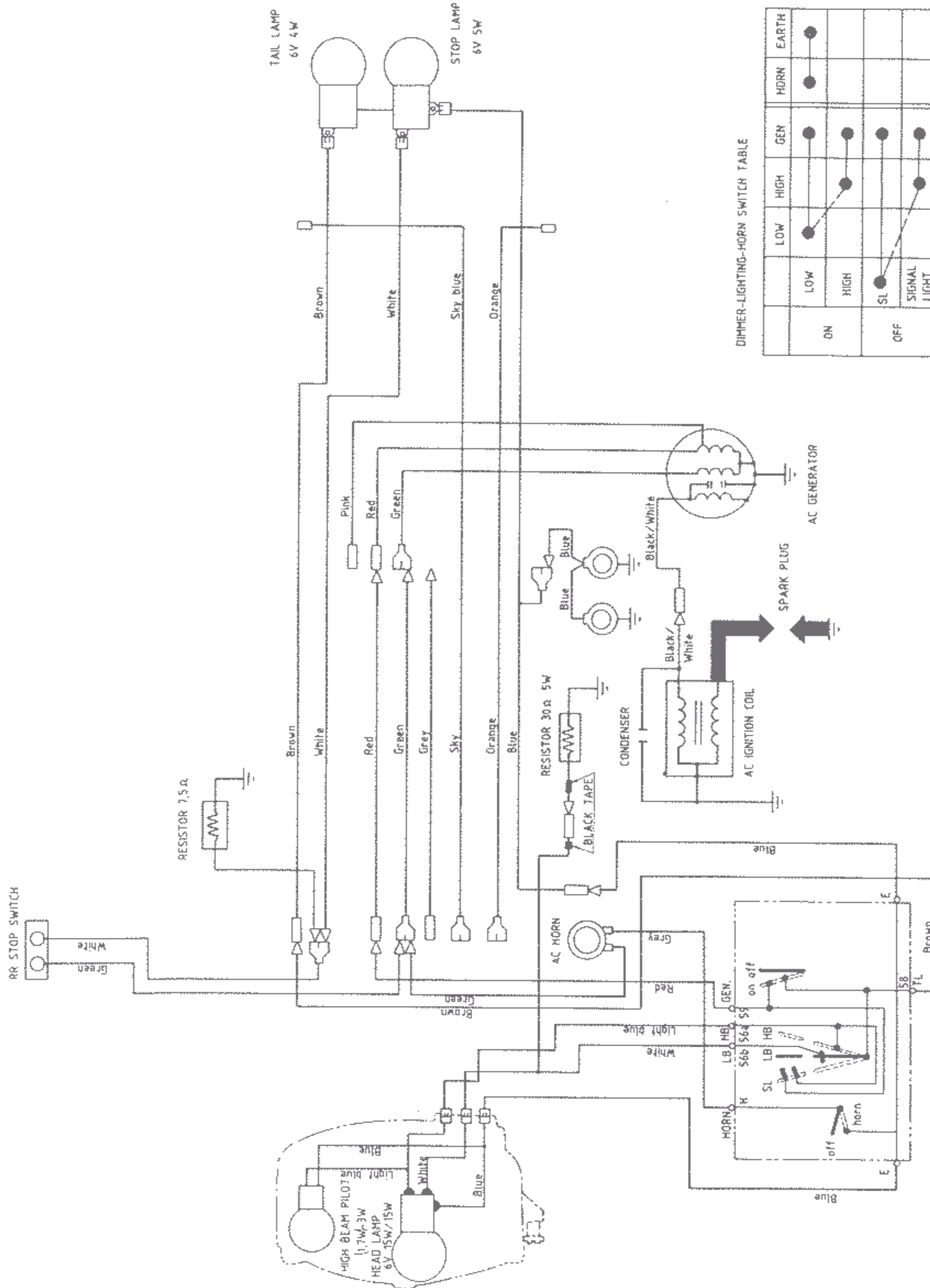

DIMMER-LIGHTING-HORN SWITCH TABLE

|     | LOW | HIGH | GEN | HDRN | EARTH |
|-----|-----|------|-----|------|-------|
| ON  | ●   | ●    | ●   | ●    | ●     |
| OFF | ●   | ●    | ●   | ●    | ●     |

DESTINATION : NORWAY

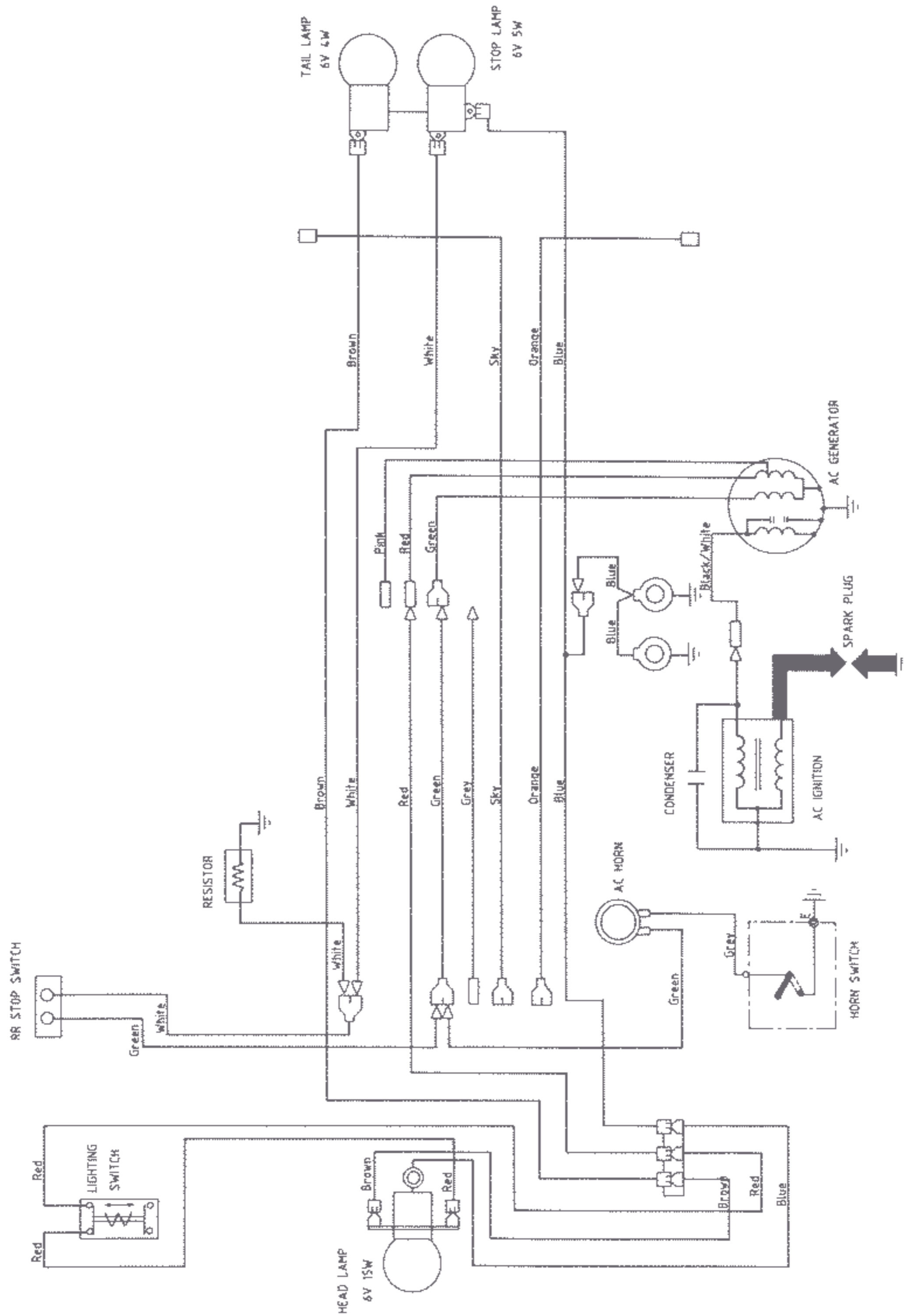

DESTINATION : S VLS-E



# HONDA PA50

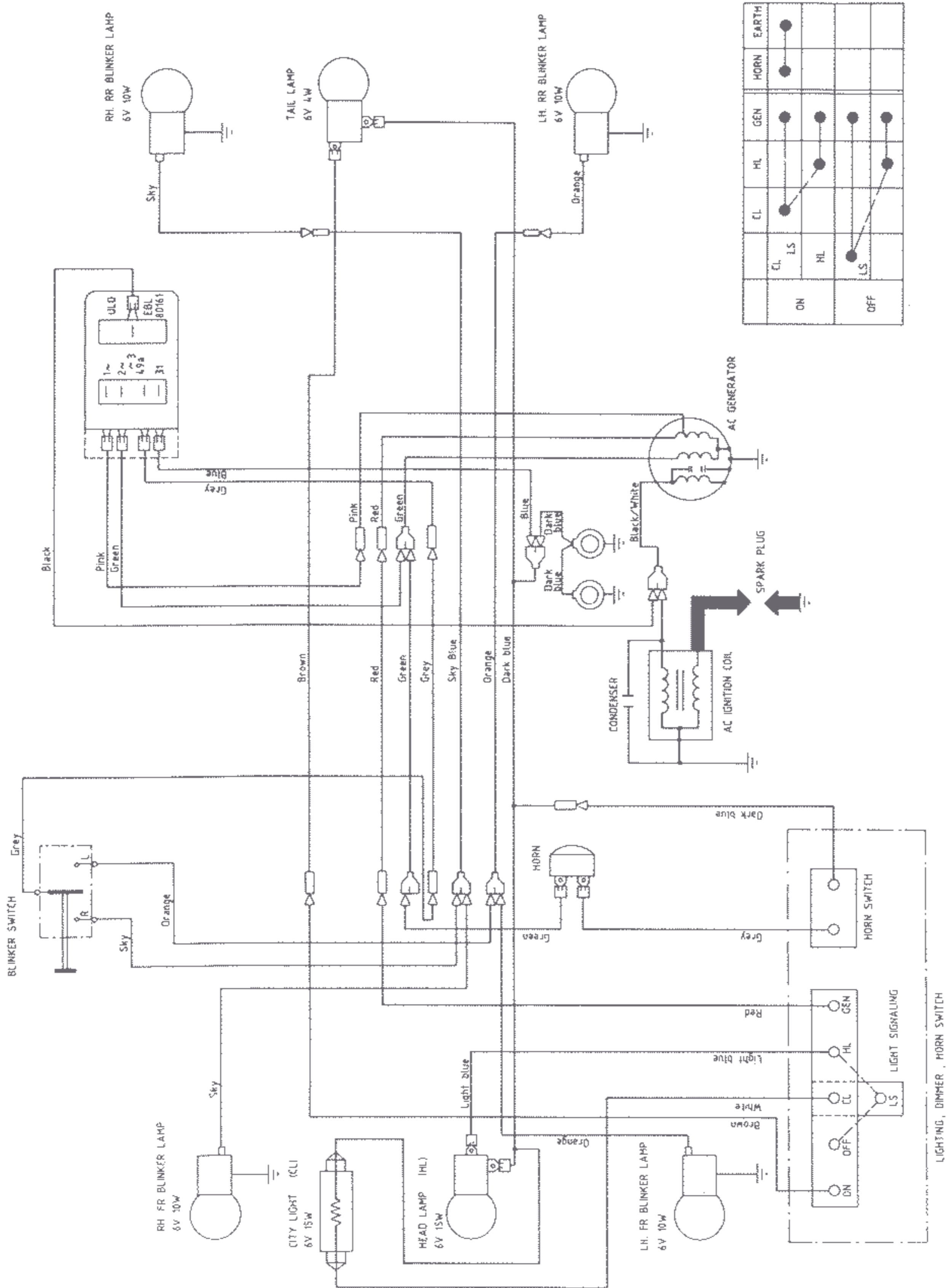

|     | CL | HL | GEN | HORN | EARTH |
|-----|----|----|-----|------|-------|
| ON  | ●  | ●  | ●   | ●    | ●     |
| OFF | ○  | ○  | ○   | ○    | ○     |

DESTINATION : IT. S VLCS

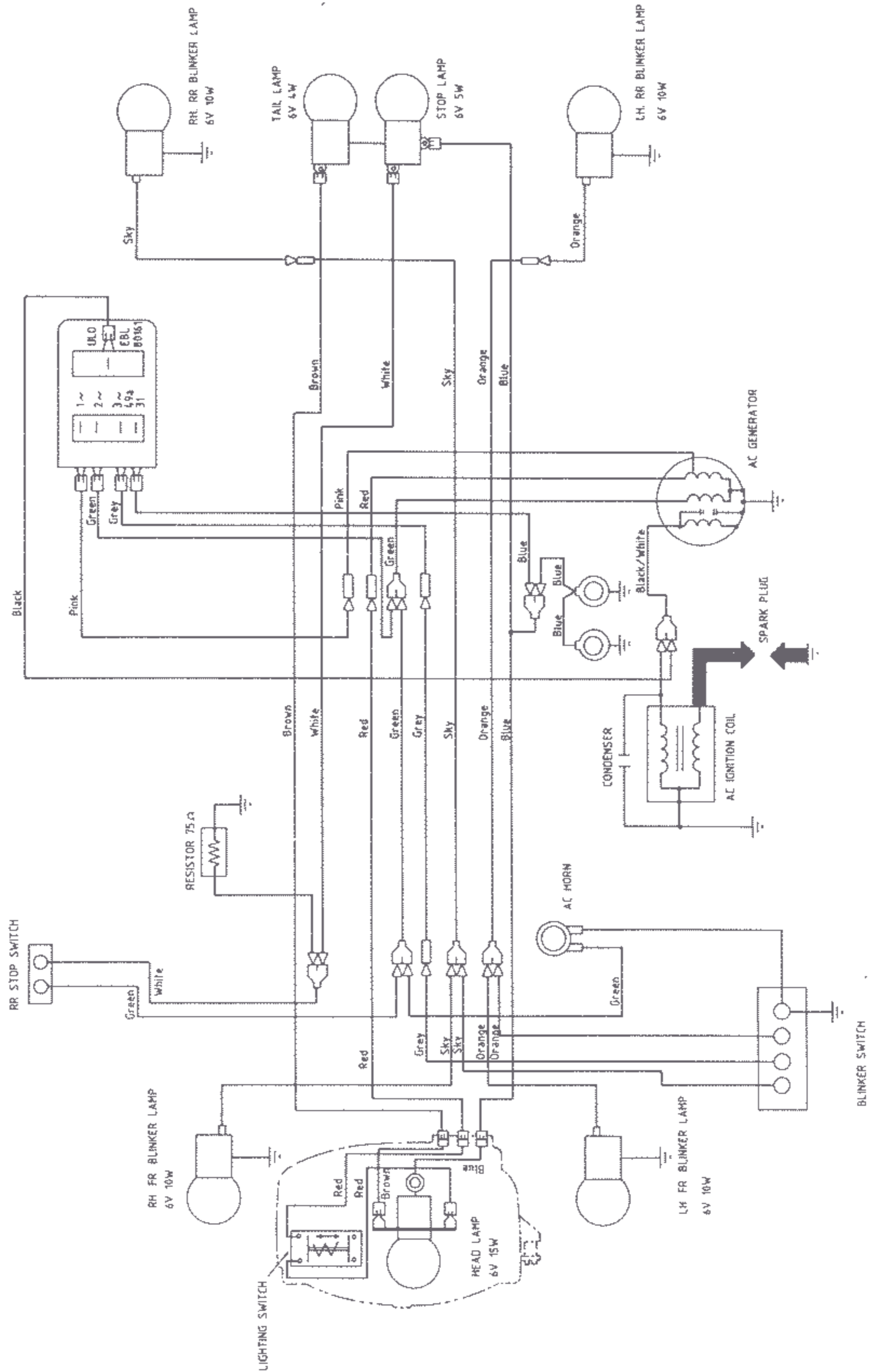

DESTINATION : SVLCSE



# HONDA PA50

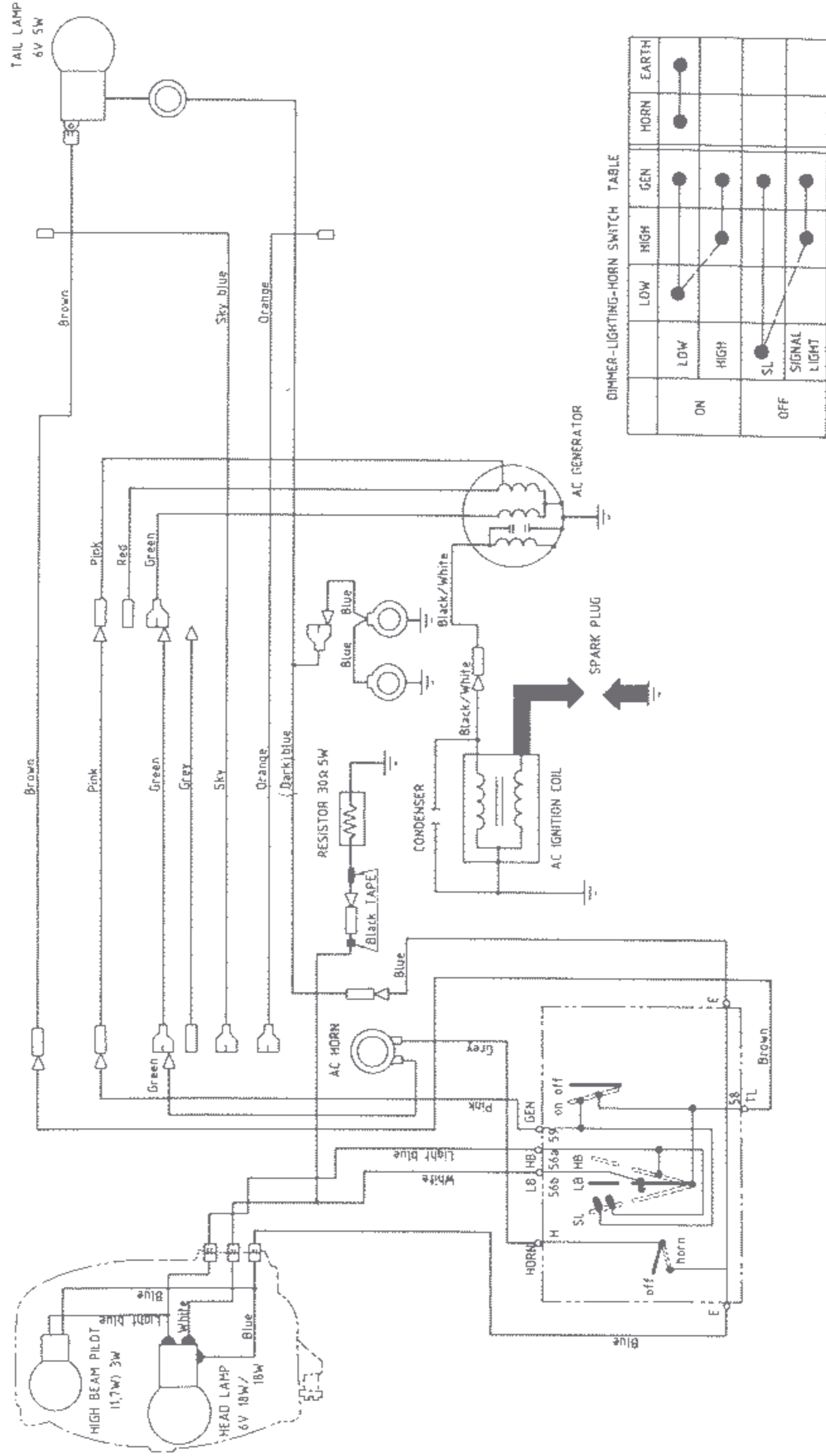

DIMMER-LIGHTING-HORN SWITCH TABLE

|     | LDW | HIGH | GEN | HORN | EARTH |
|-----|-----|------|-----|------|-------|
| ON  | ●   | ●    | ●   | ●    | ●     |
| OFF | ●   | ●    | ●   | ●    | ●     |

DESTINATION : GB-S VLS  
DX VL

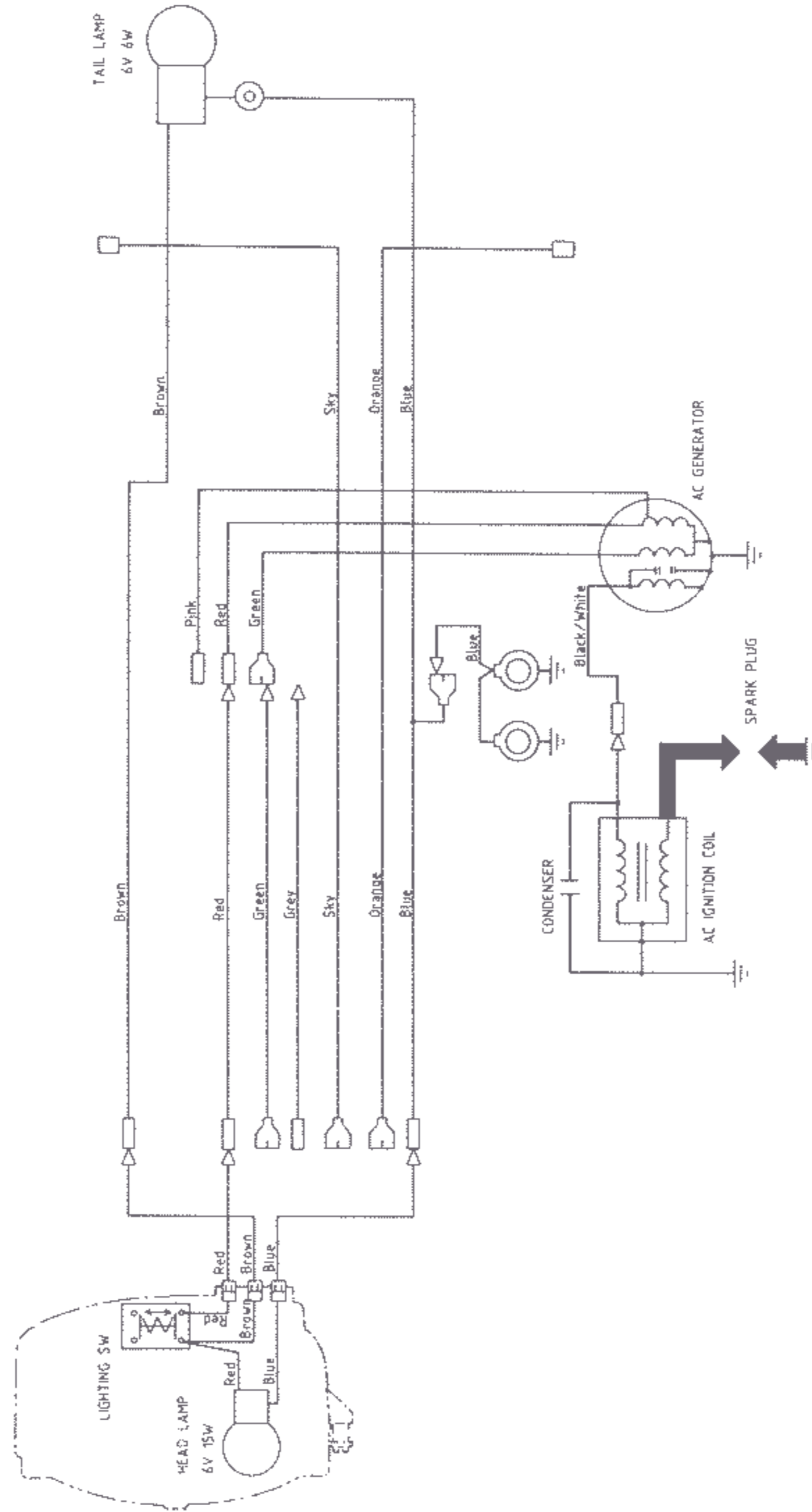

DESTINATION : CH



# HONDA PA50

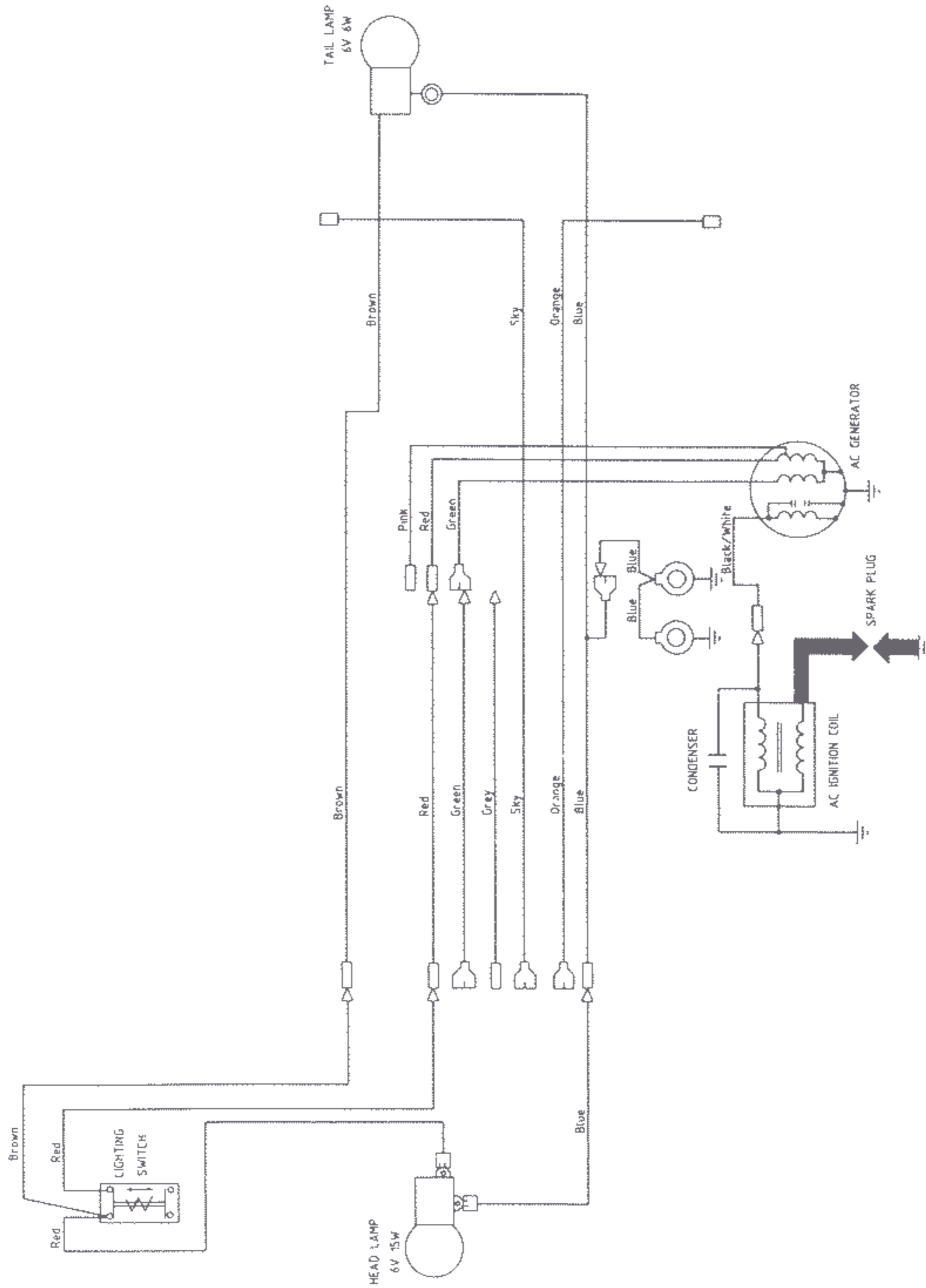

DESTINATION : MSVLS-CH



## 6. TROUBLE SHOOTING

### A. Engine does not start or is hard to start

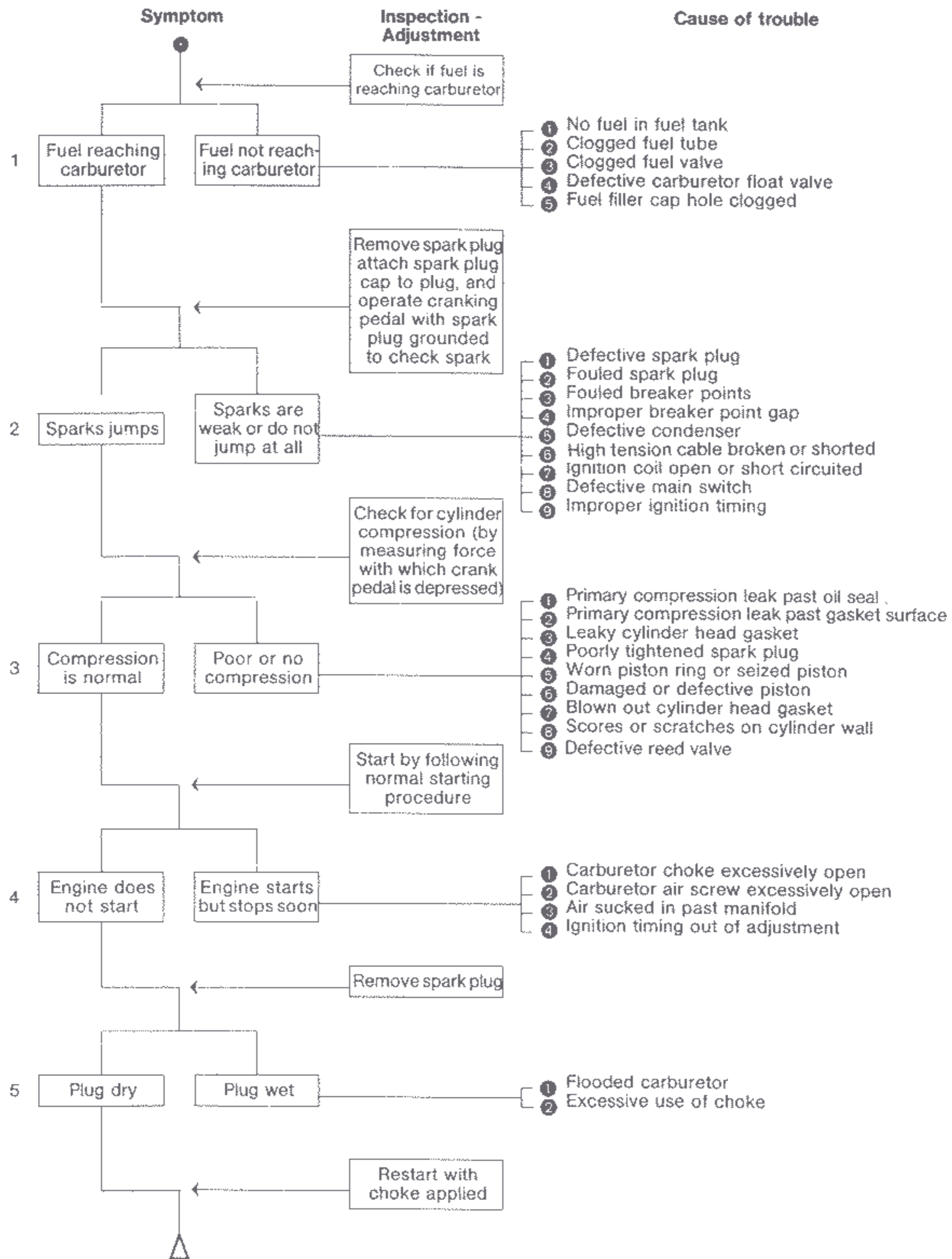



## 6. TROUBLE SHOOTING

### B. Engine lacks power

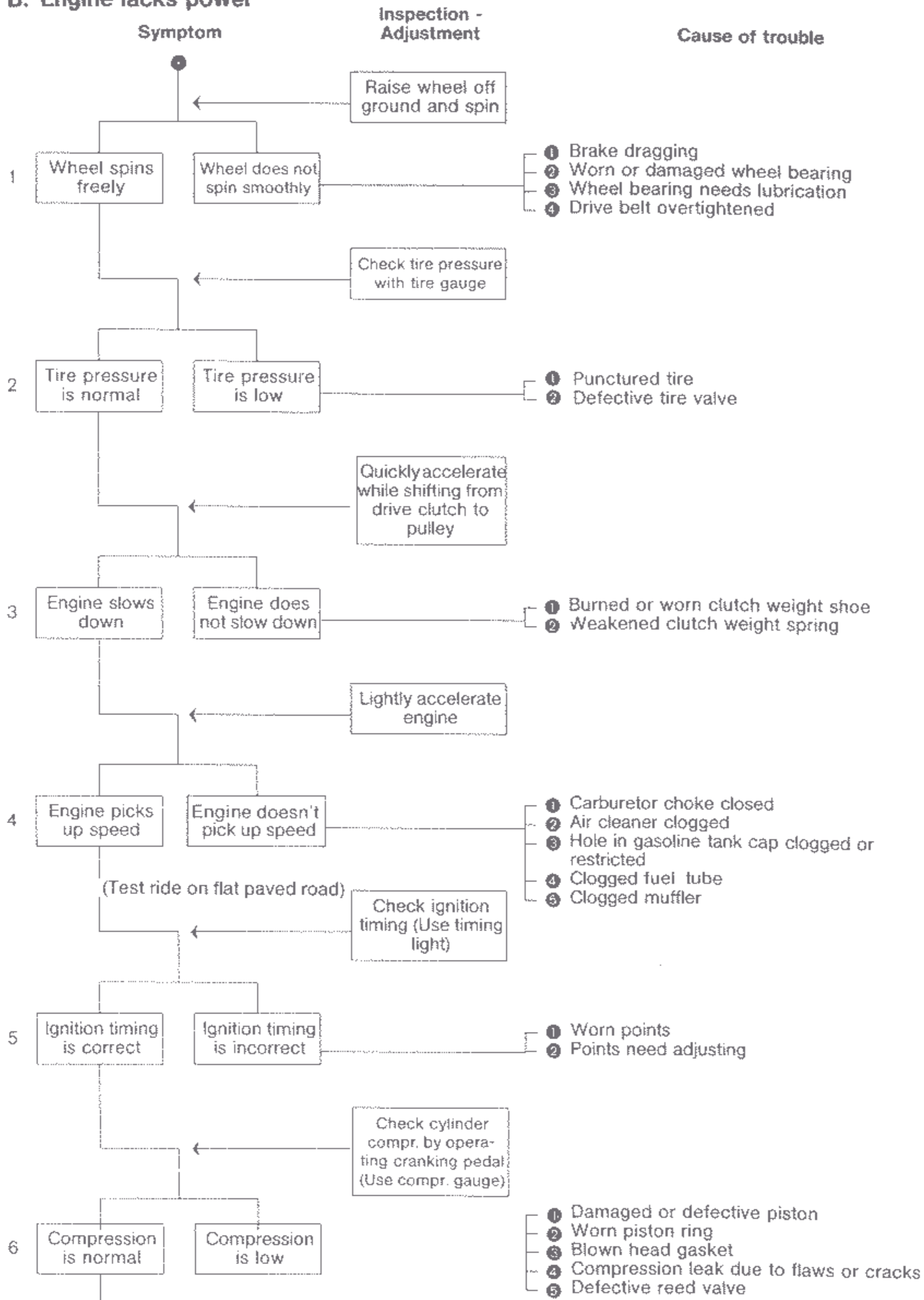

**6. TROUBLE SHOOTING**

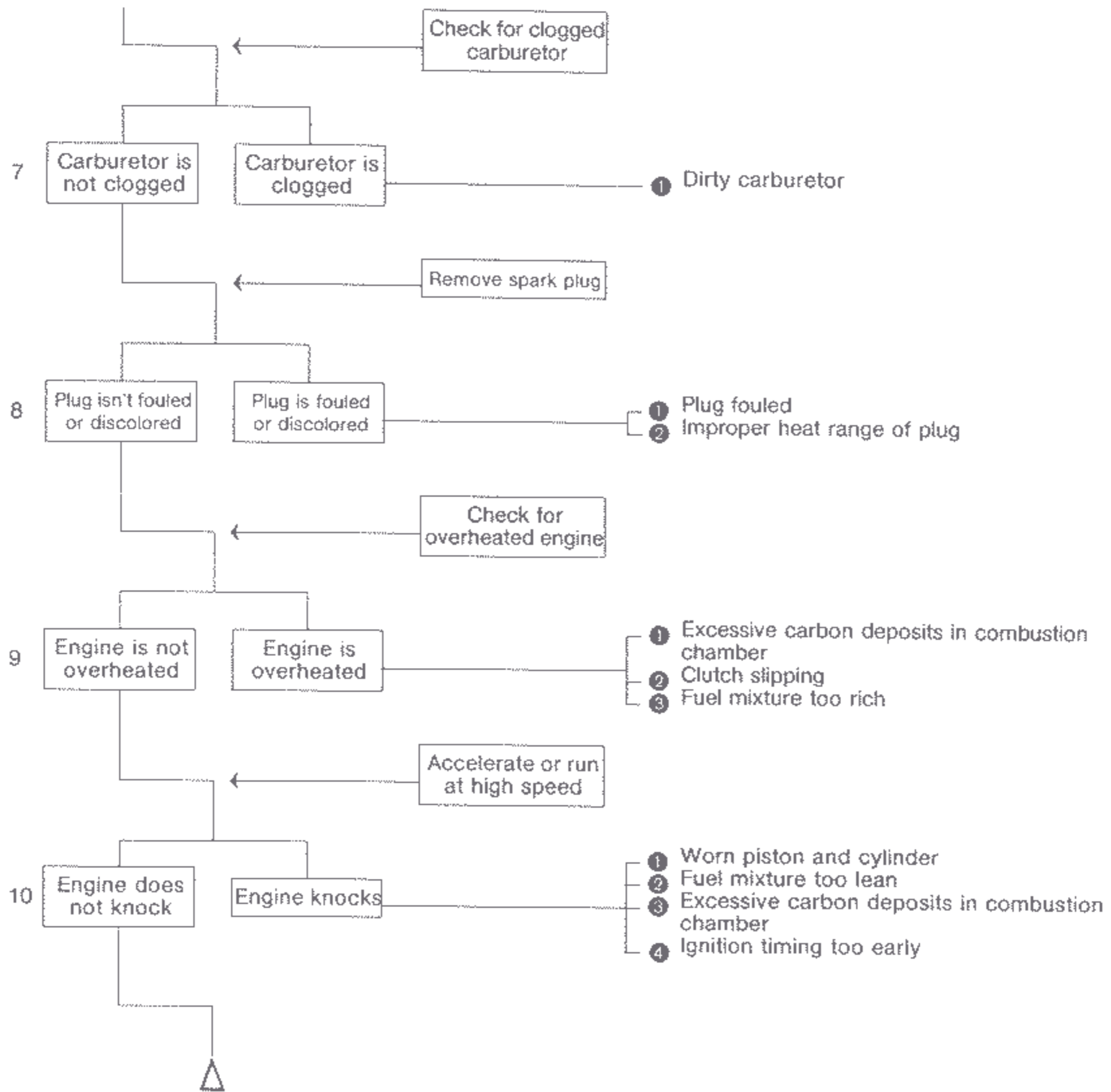



## 6. TROUBLE SHOOTING

### C. Clutch not operating correctly

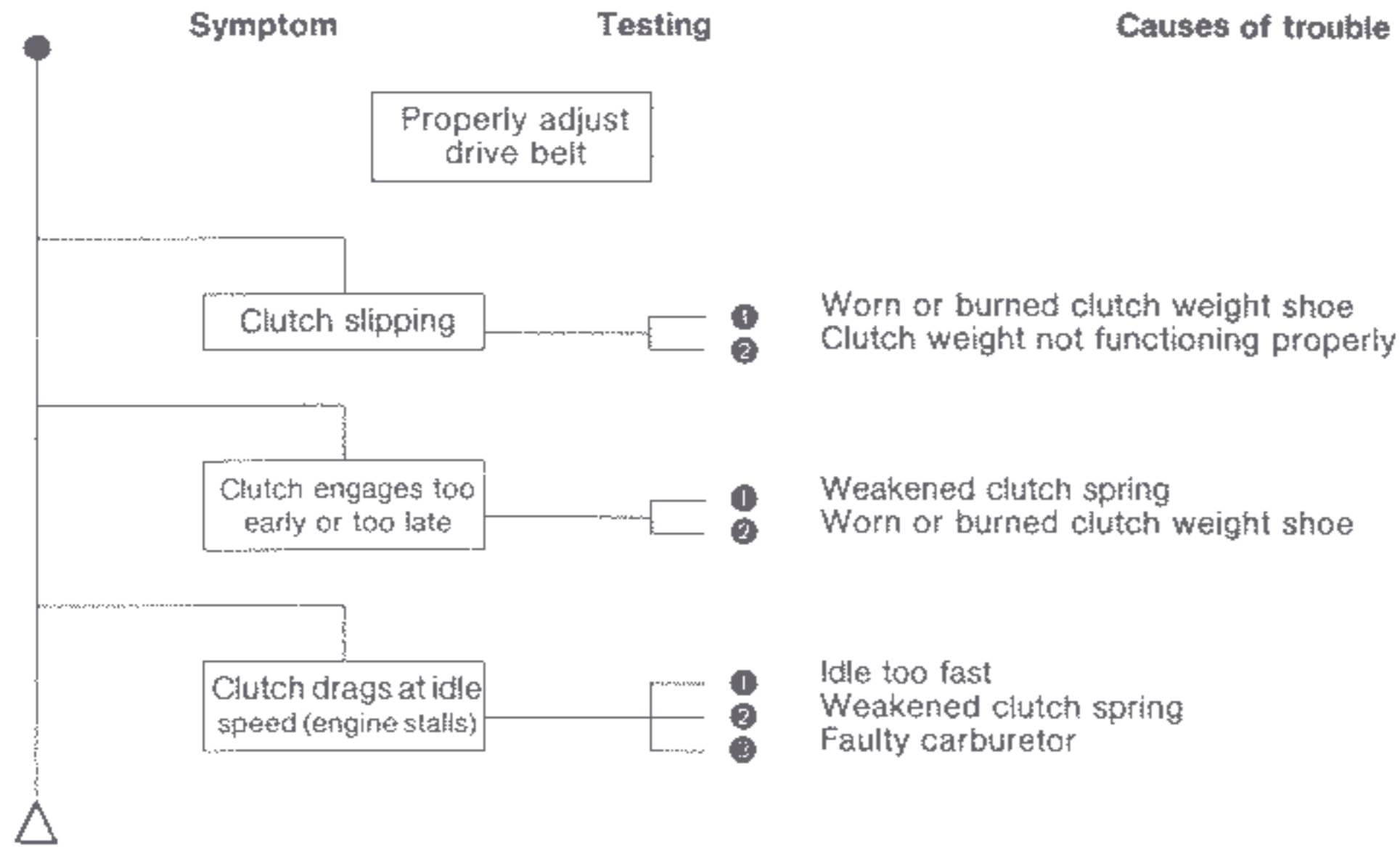

### D. Engine noise

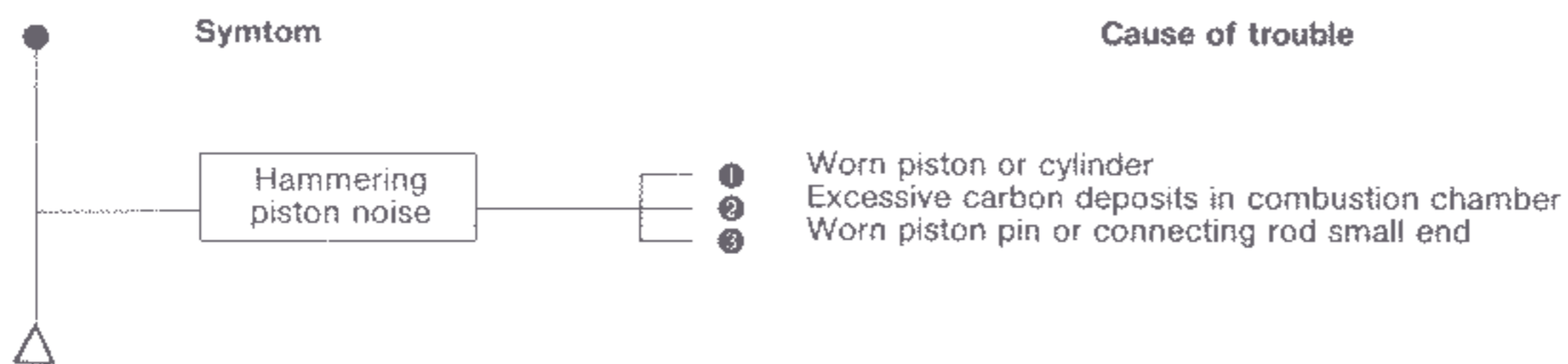

**6. TROUBLE SHOOTING**

**E. Motorcycle pulls to one side**

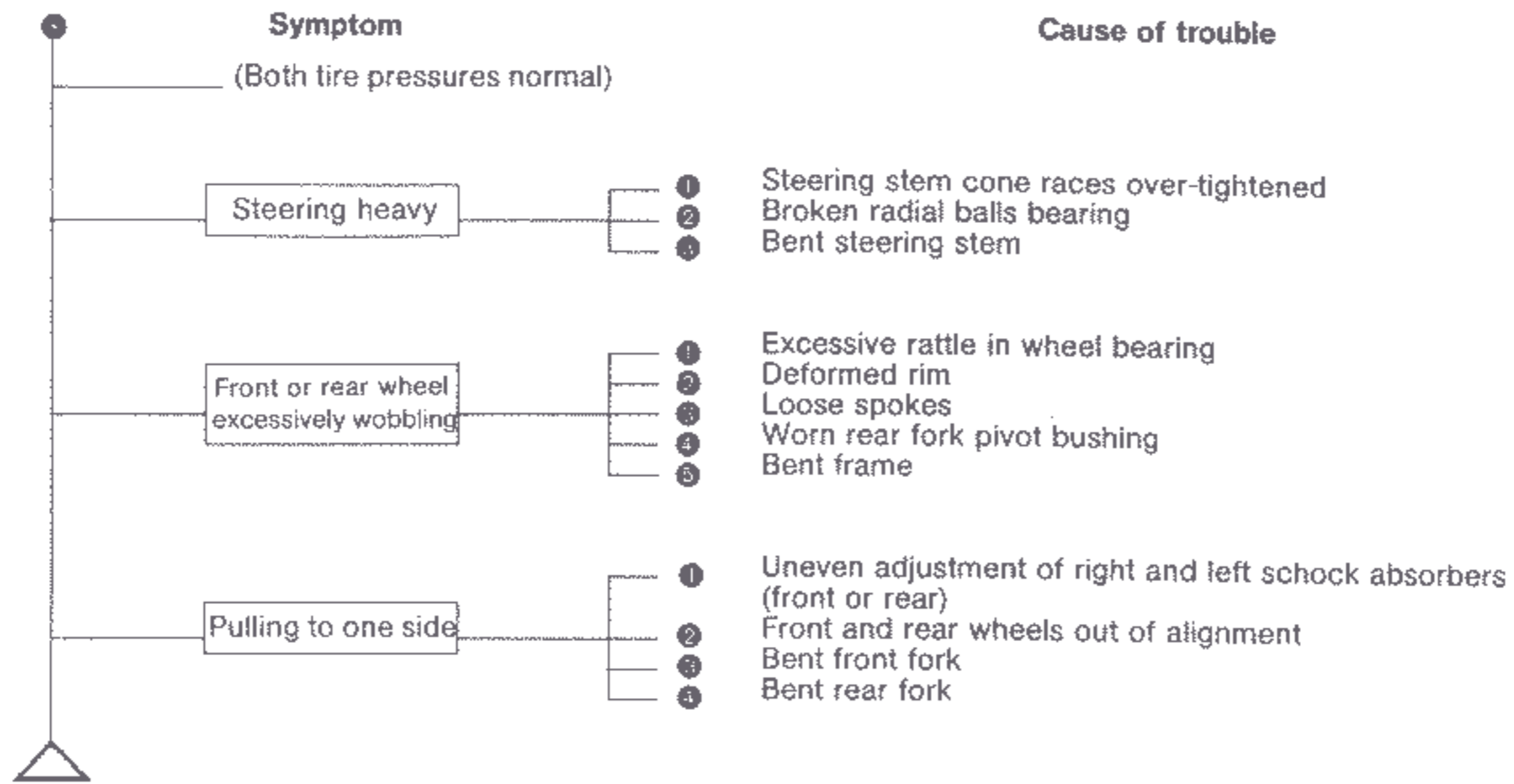

**F. Improper front/rear shock absorber**

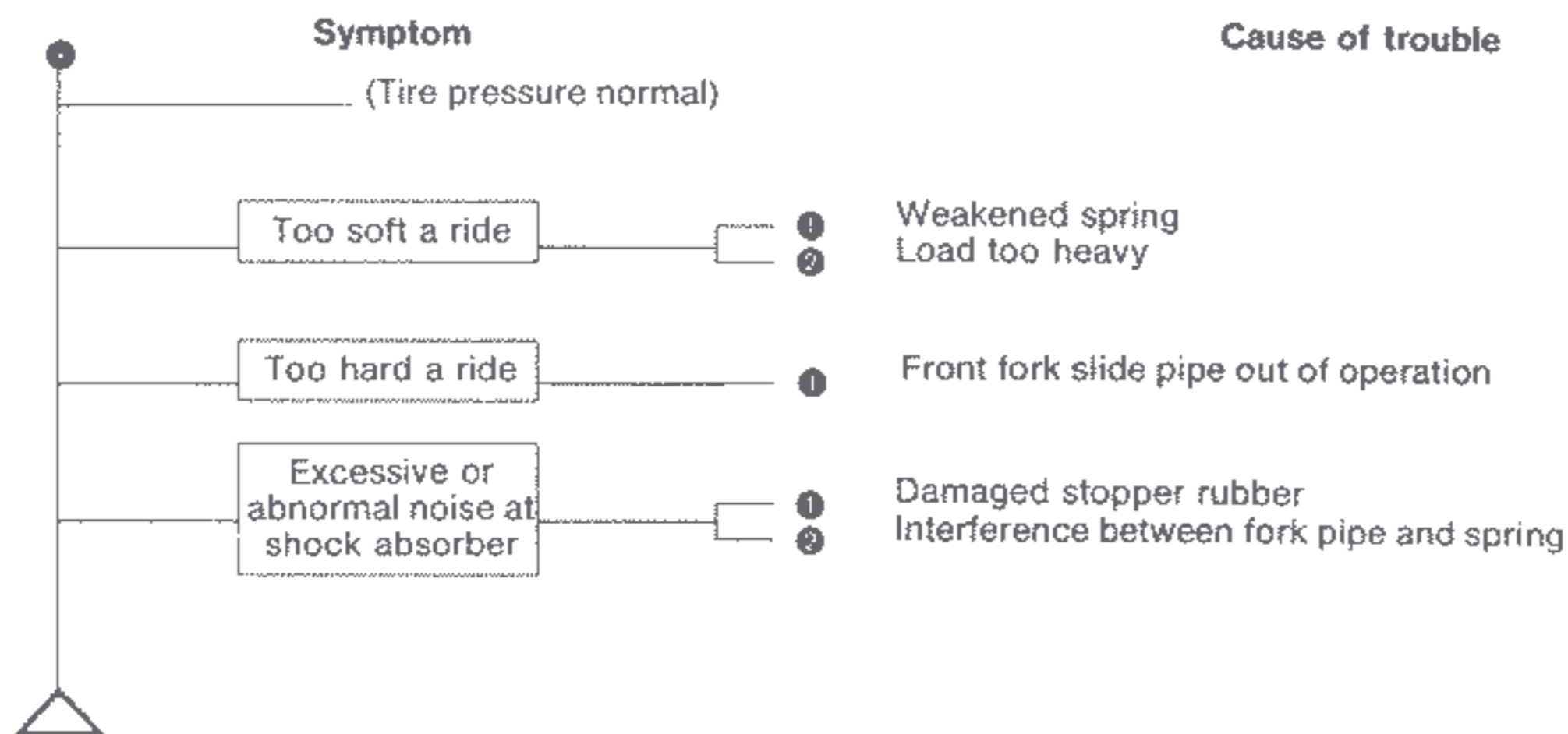



## 6 TROUBLE SHOOTING

### G. Improper braking

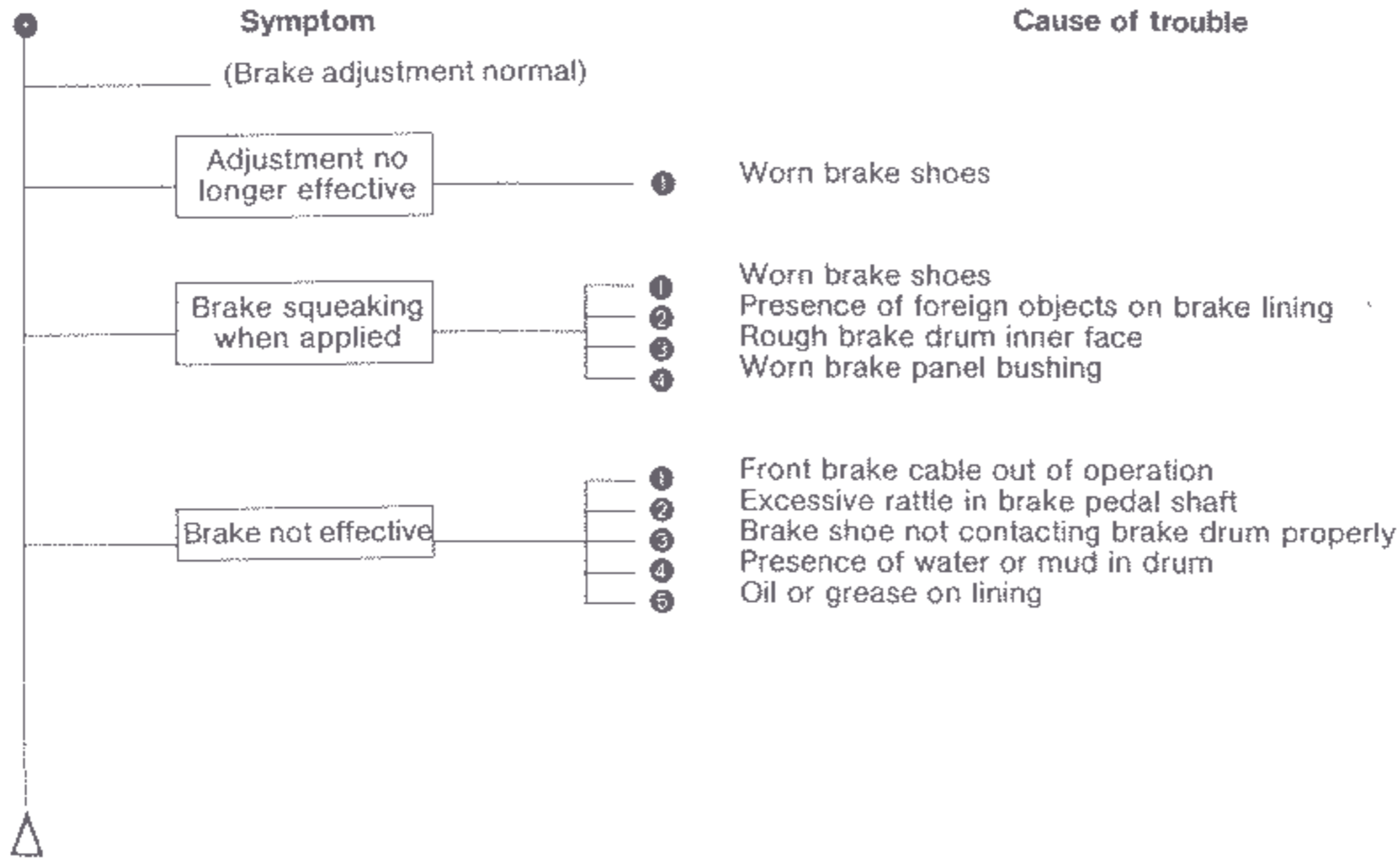



## 7. Maintenance schedule

| MAINTENANCE SCHEDULE<br>This maintenance schedule is based upon average riding conditions. Machines subjected to severe use, or ridden in unusually dusty areas, require more frequent servicing. | Pre-riding inspection | Initial safety inspection | Regular service period<br>Perform at every indicated month or mileage interval, whichever occurs first. |                        |                           |
|---|-----------------------|---------------------------|---|------------------------|---------------------------|
|   |                       |                           | 1 month<br>300 miles  | 12 months<br>600 miles | 24 months-<br>2,000 miles |
| * Sparking plug   |                       |                           |   | R                      |                           |
| * Contact breaker points  |                       | I                         | I   |                        |                           |
| * Ignition timing   |                       | I                         | I   |                        |                           |
| * Air filter element  |                       | (Every 6 months) C        |   |                        |                           |
| * Carburetor  |                       |                           | I   |                        |                           |
| Throttle operation  | I                     |                           |   |                        |                           |
| * Fuel filter screen  |                       | C                         | C   |                        |                           |
| Fuel level  | I                     |                           |   |                        |                           |
| Fuel lines  | I                     |                           |   |                        |                           |
| * Clutch shoes  |                       |                           |   |                        | I                         |
| * Decarbonize cylinder and muffler  |                       |                           |   |                        | C                         |
| * V-belt and pedal chain  |                       | I                         |   |                        |                           |
| * Brake linings   |                       |                           | I   |                        |                           |
| * Brake operation and free play   | I                     |                           |   |                        |                           |
| Tires and pressure  | I                     |                           |   |                        |                           |
| * Wheel trueness and spokes   |                       | I                         | I   |                        |                           |
| * Front and rear suspension   |                       |                           | I   |                        | L                         |
| All lights and horn   | I                     |                           |   |                        |                           |
| * Nuts, bolts (tighten)   |                       | I                         | I   |                        |                           |
| * Slide pipes   |                       |                           |   |                        | L                         |

I - Inspect, clean, adjust or replace if necessary  
 R - Replace  
 C - Clean  
 L - Lubricate

Items marked\* should be serviced by an authorized Honda dealer, unless the owner has proper tools and is mechanically proficient. Other maintenance items may be serviced by the owner.

**4. INSPECTION/ADJUSTEMENT**

|  |    |
|--|----|
| 1. Contact breaker point/ignition timing ..... | 37 |
| 2. Spark plug .....                            | 38 |
| 3. Air cleaner element .....                   | 39 |
| 4. Drive belt .....                            | 40 |
| 5. Drive chain .....                           | 41 |
| 6. Seat .....                                  | 41 |
| 7. Brake .....                                 | 42 |





# HONDA<sup>®</sup> PA50

## 1. Contact breaker point gap / Ignition timing

Remove the generator cover.

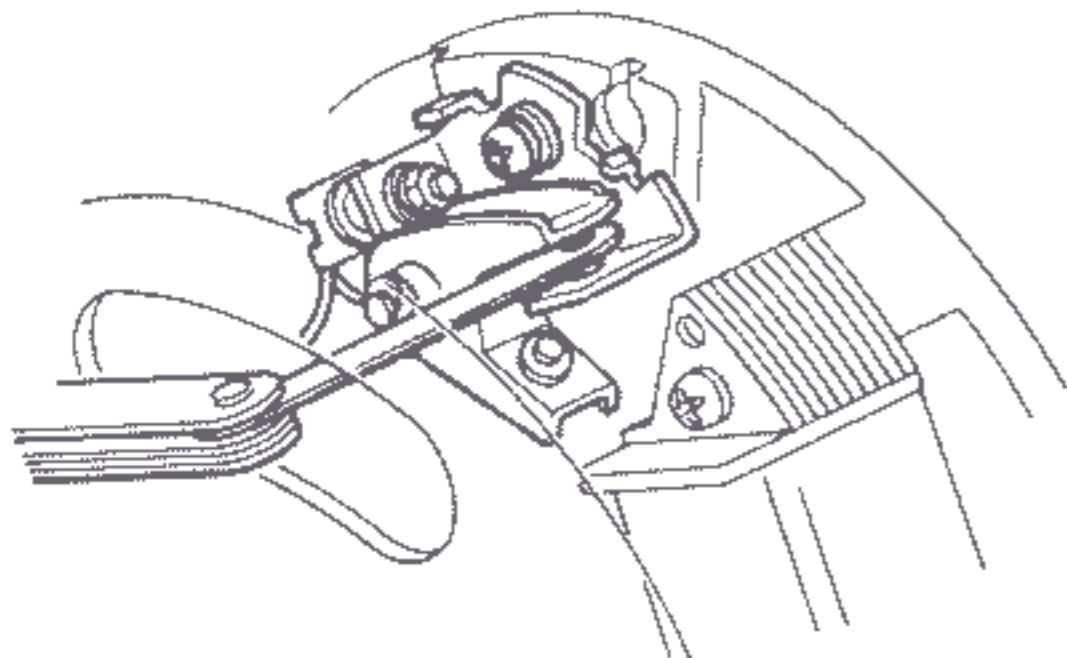

- ① Insert a thickness gauge through the rotor hole
- ② Check point gap

|           |              |
|-----------|--------------|
| point gap | 0.3 - 0.4 mm |
|-----------|--------------|

Replace if beyond specifications.

### ● Ignition timing with a testlamp

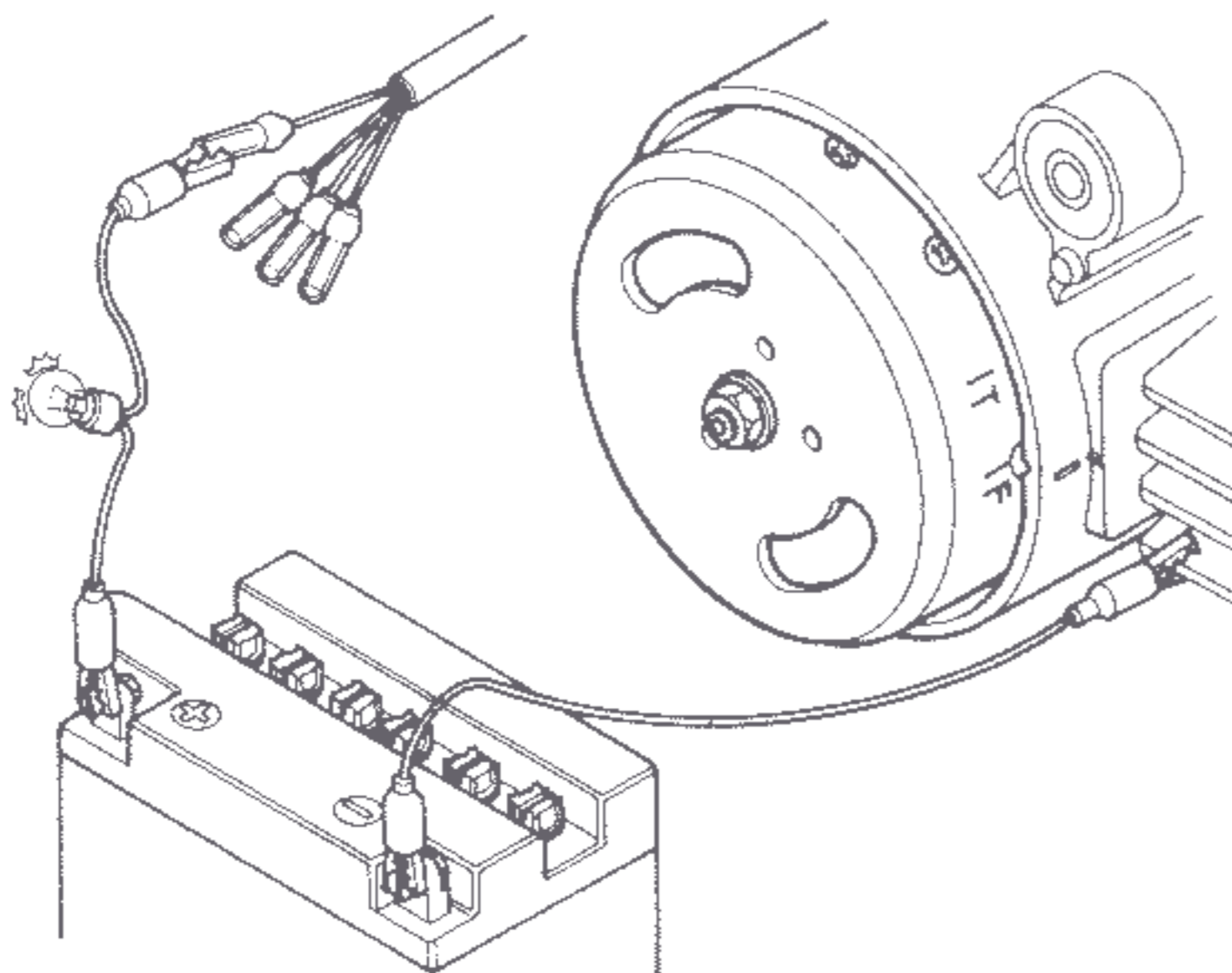

- ① Turn the flywheel clockwise until the "F" mark aligns with the index mark.  
Timing is correct if the lamp dims when the marks align.

- ① To adjust, loosen the locking screw and move the contact breaker plate to obtain the correct ignition timing when the lamp dims with the marks aligned. Recheck point gap. If the gap is more than 0.4 mm, the points should be replaced.

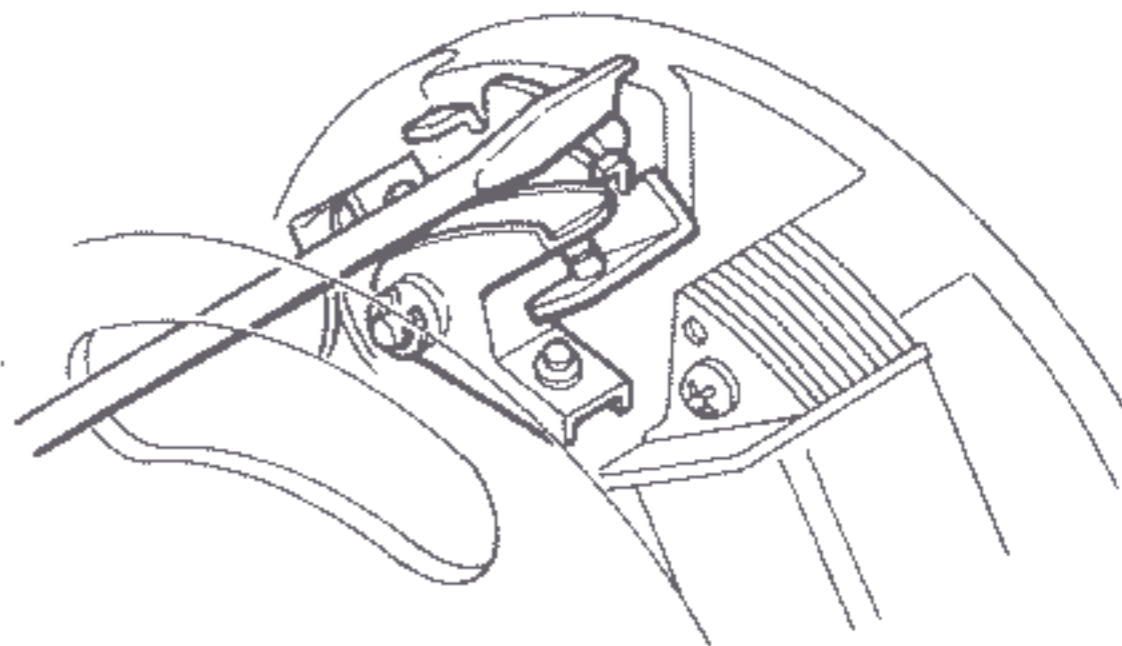



# HONDA PA50

## 2. Spark Plug

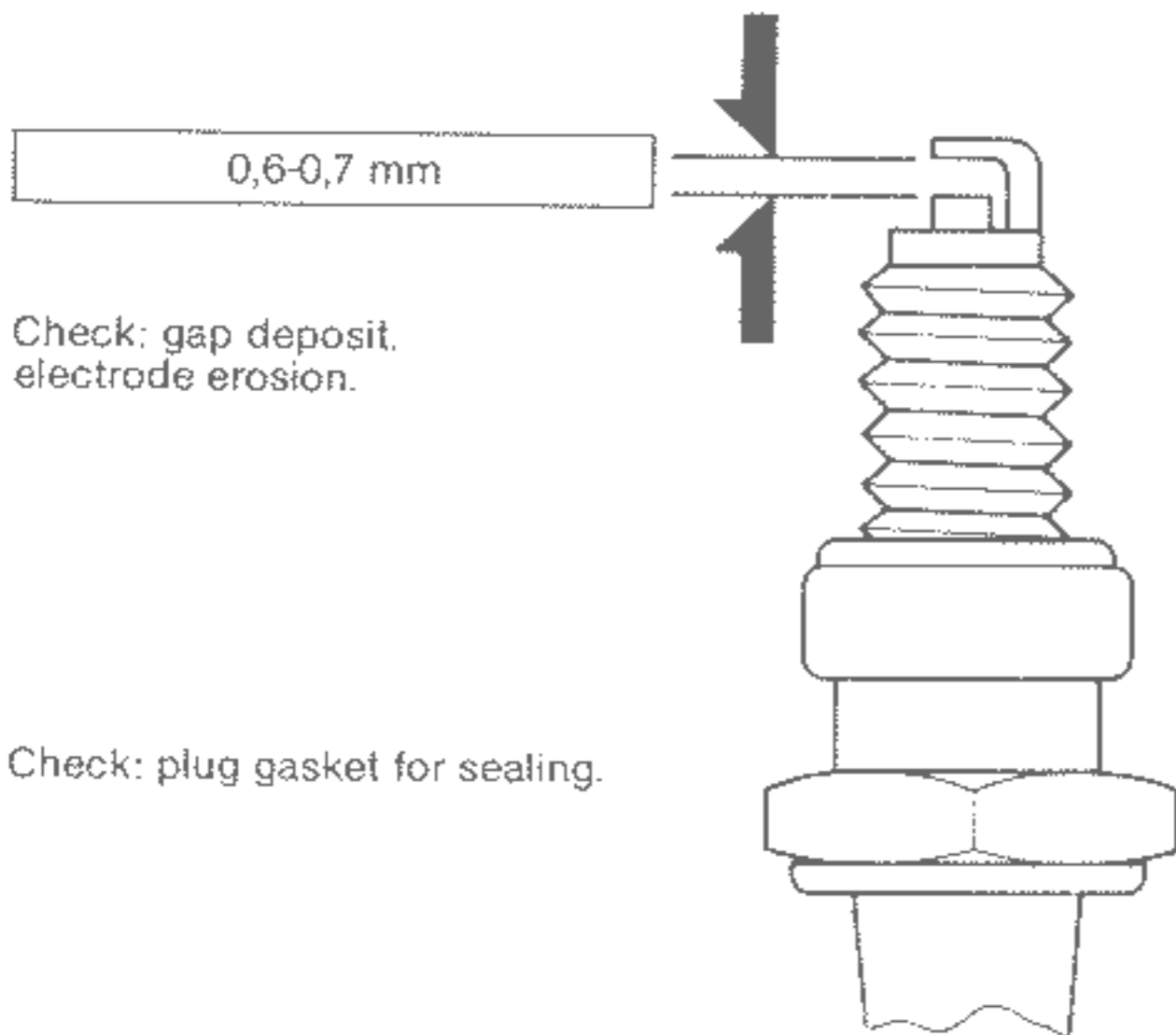

Check: gap deposit,  
electrode erosion.

Check: plug gasket for sealing.

Always use specified spark plug  
BPR-6HS (NGK)  
W20FPR (ND)

A spark plug with burned electrodes or a damaged gasket should be replaced.

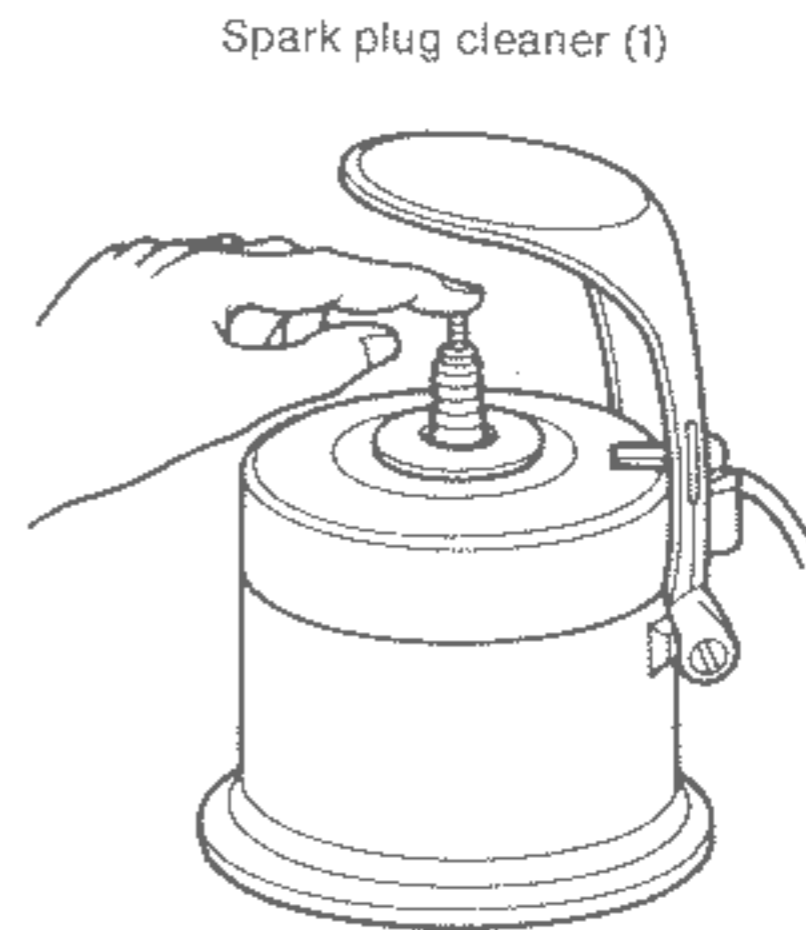

## 3. Carburetor

● Engine idle adjustment.

Start and warm up the engine for a few minutes

- ① Turn the throttle stop screw to the lowest idle speed.
- ② Turn the air screw in or out to find the highest idle speed.
- ③ Set the engine at the idle speed by turning the throttle stop screw.

Idle speed: 1.500 RPM



THIS PRODUCT SYSTEM IS A MANUFACTURED  
PRODUCTS TO ELIMINATE EXCESSIVE  
EMISSIONS AND IMPROVE PERFORMANCE UNDER  
VARIABLE OPERATING CONDITIONS.



# HONDA PA50

## 3. Air cleaner element

- 1 Remove the drive belt cover.
- 2 Release the air cleaner case retaining clip and pull the air cleaner case out.
- 3 Remove the air cleaner element from air cleaner case.
- 4 Wash the element in solvent and allow to dry thoroughly. Soak the element in clean gear oil, until saturated, then squeeze out excess oil.

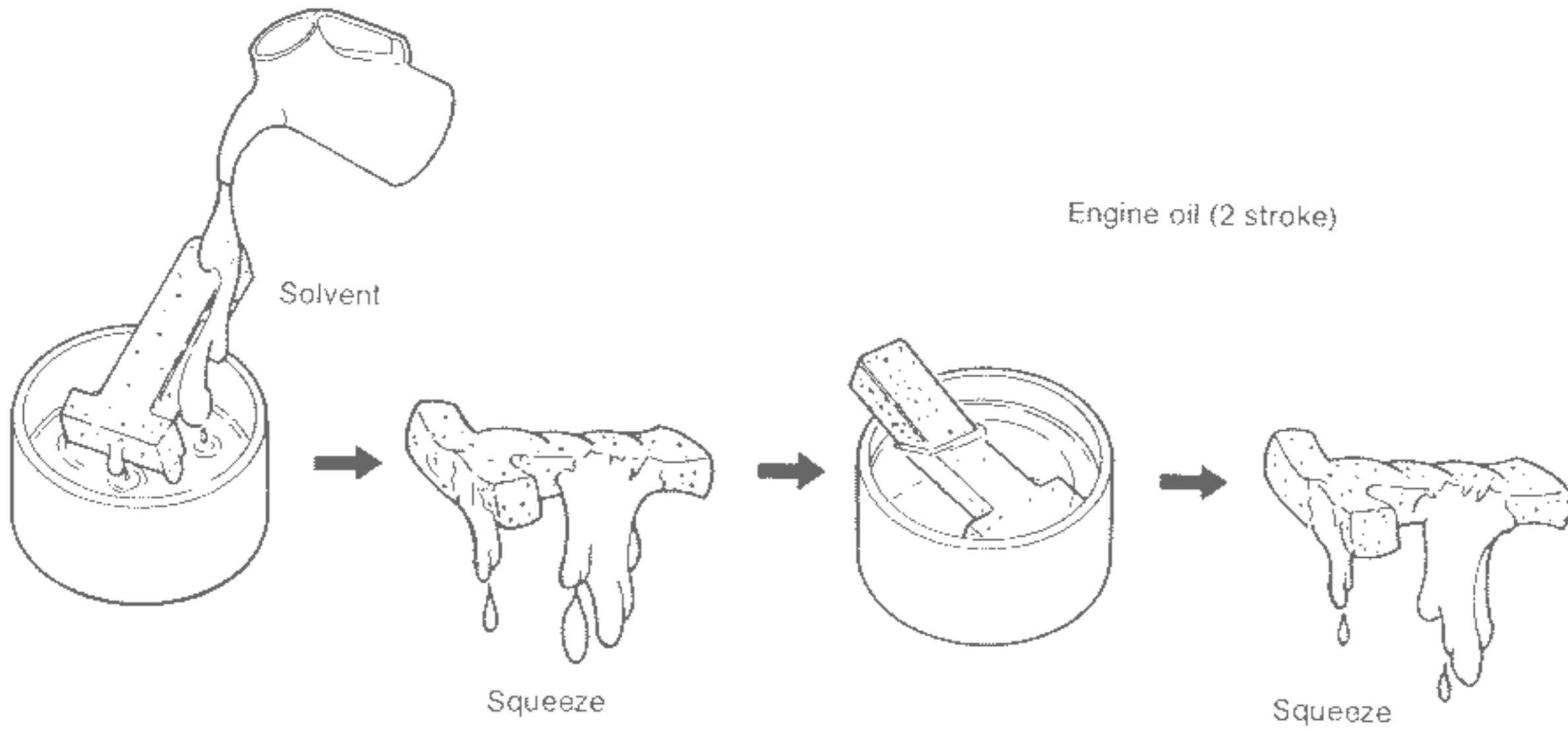

- 5 Reinstall the aircleaner element into the case.

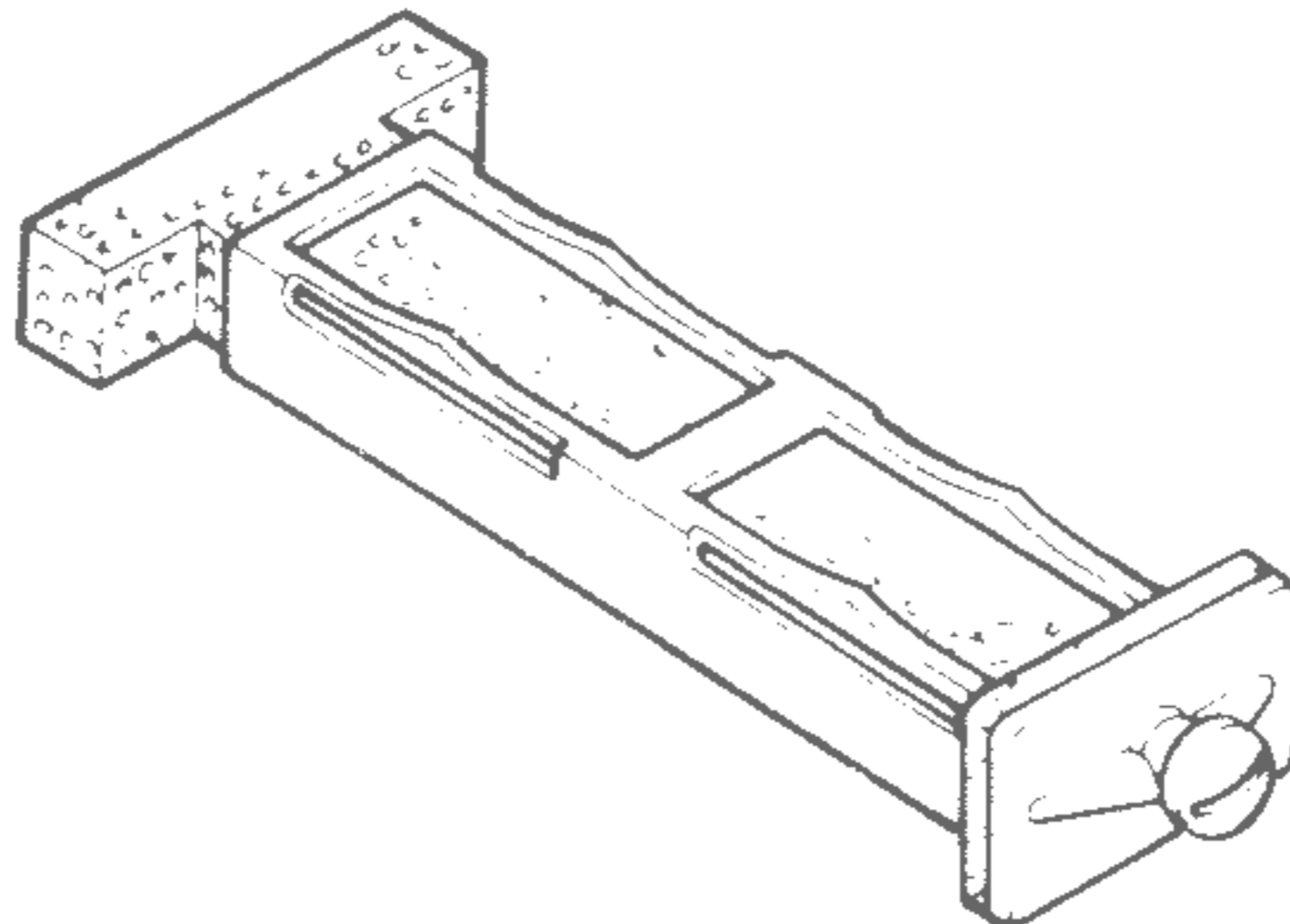



## 4. Drive belt

- ① Remove the drive belt cover and chain cover.
- ② Loosen the four rear fork bolts.
- ③ Adjust the drive belt so that the distance between the belt face and driven pulley outside diameter is 2 mm when pressure is applied midway between pulleys.
- ④ Move the wheel backward and tighten the bolts in the following order.

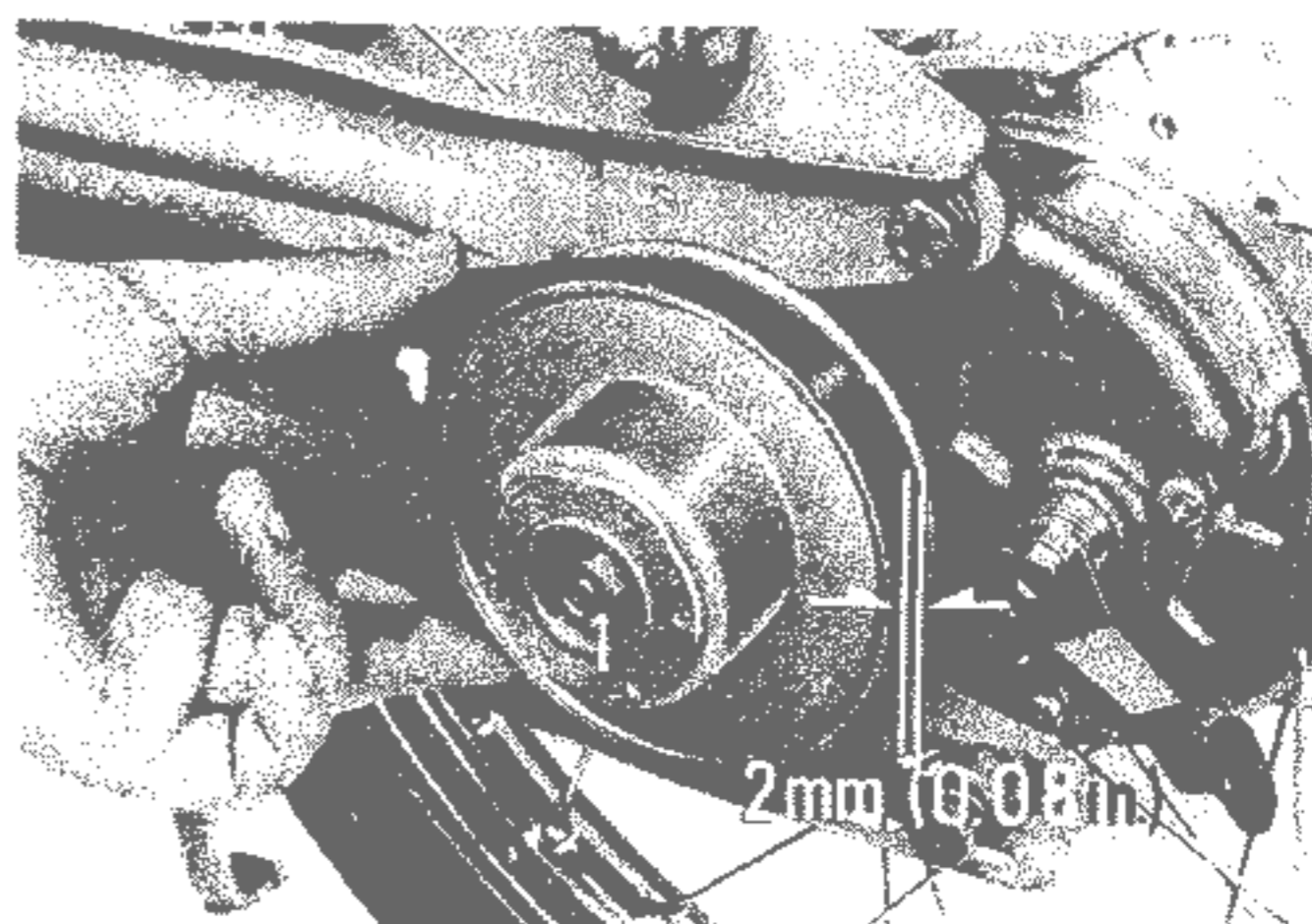

### NOTE:

The right and left lower bolts should be aligned with the same notches in the side scales on the rear fork.

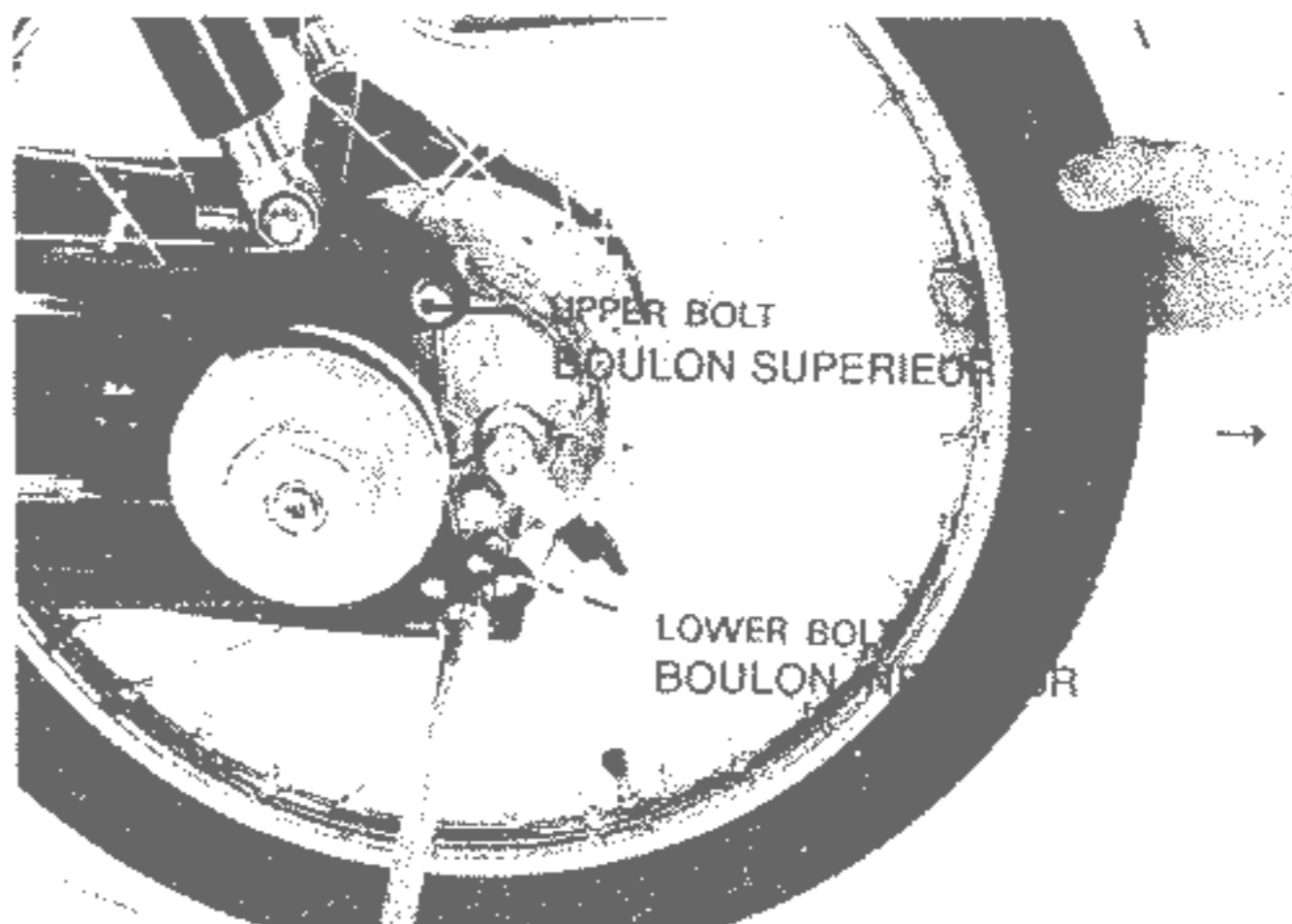

- ⑤ Operate the pedal several times and make sure that the belt is at "Low" and distance between the belt face and the driven pulley outside diameter is 2 mm.
- ⑥ Start the engine and make sure that the belt does not slip on the pulleys at stall revolution.

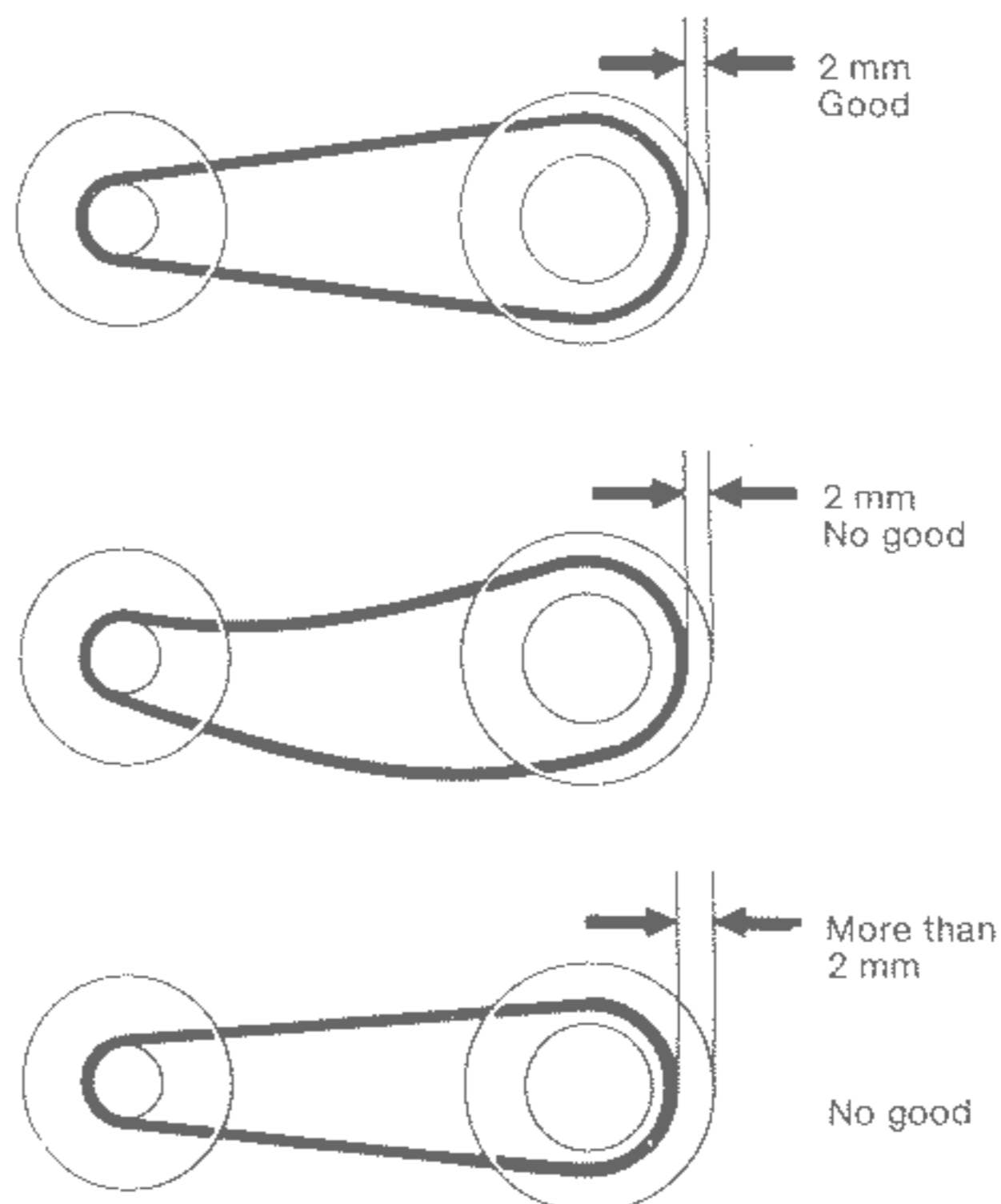



# HONDA PA50

## 5. Drive chain

- 1 Remove the chain cover.
- 2 Loosen the tensioner bolts and adjust the drive chain.

|             |         |
|-------------|---------|
| Chain slack | 5-10 mm |
|-------------|---------|

### NOTE:

Adjust the drive chain tension after drive belt adjustment.

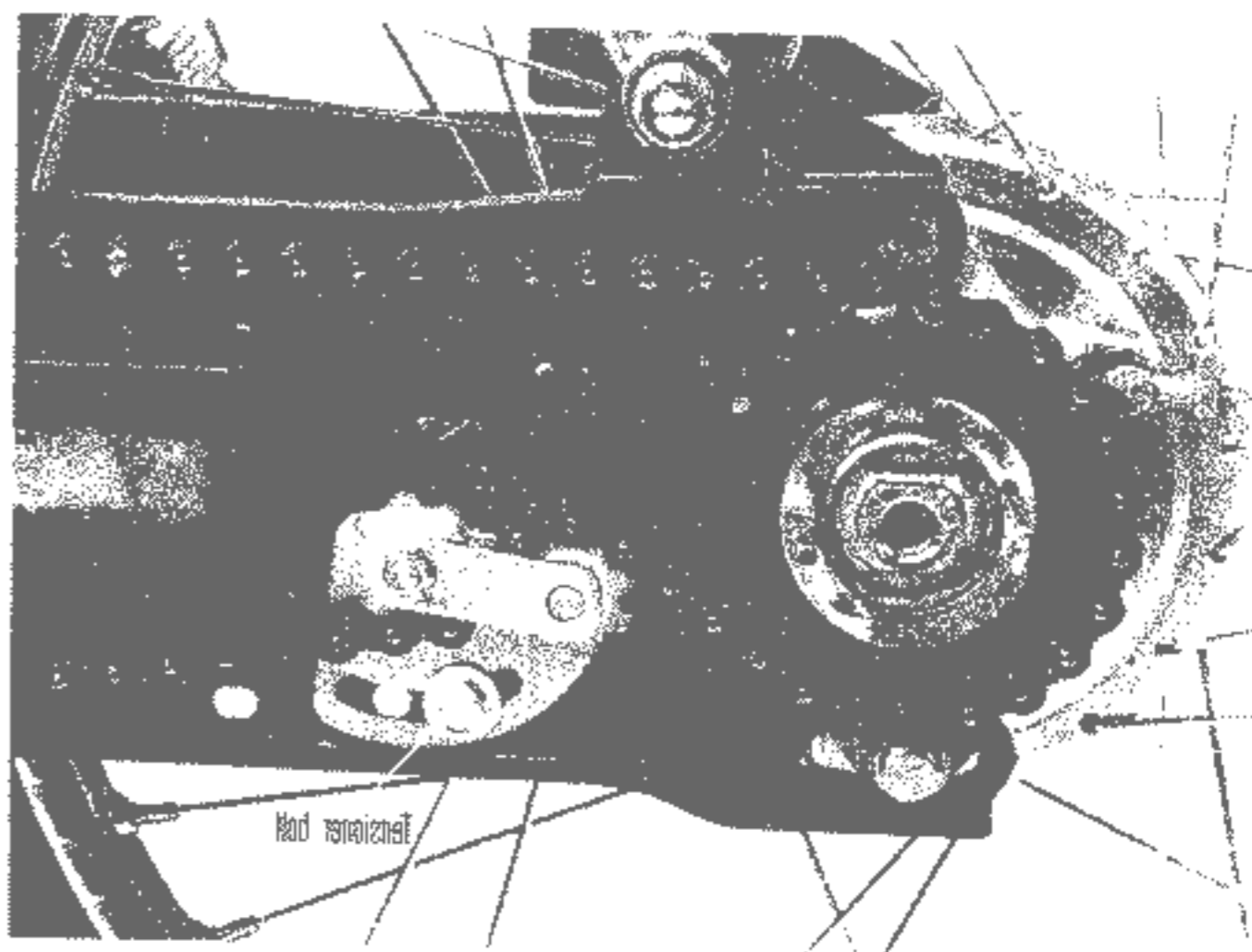

## 6. Seat

- 1 Loosen the adjusting bolt.
- 2 Adjust the seat to a suitable height and secure with the adjusting bolt.

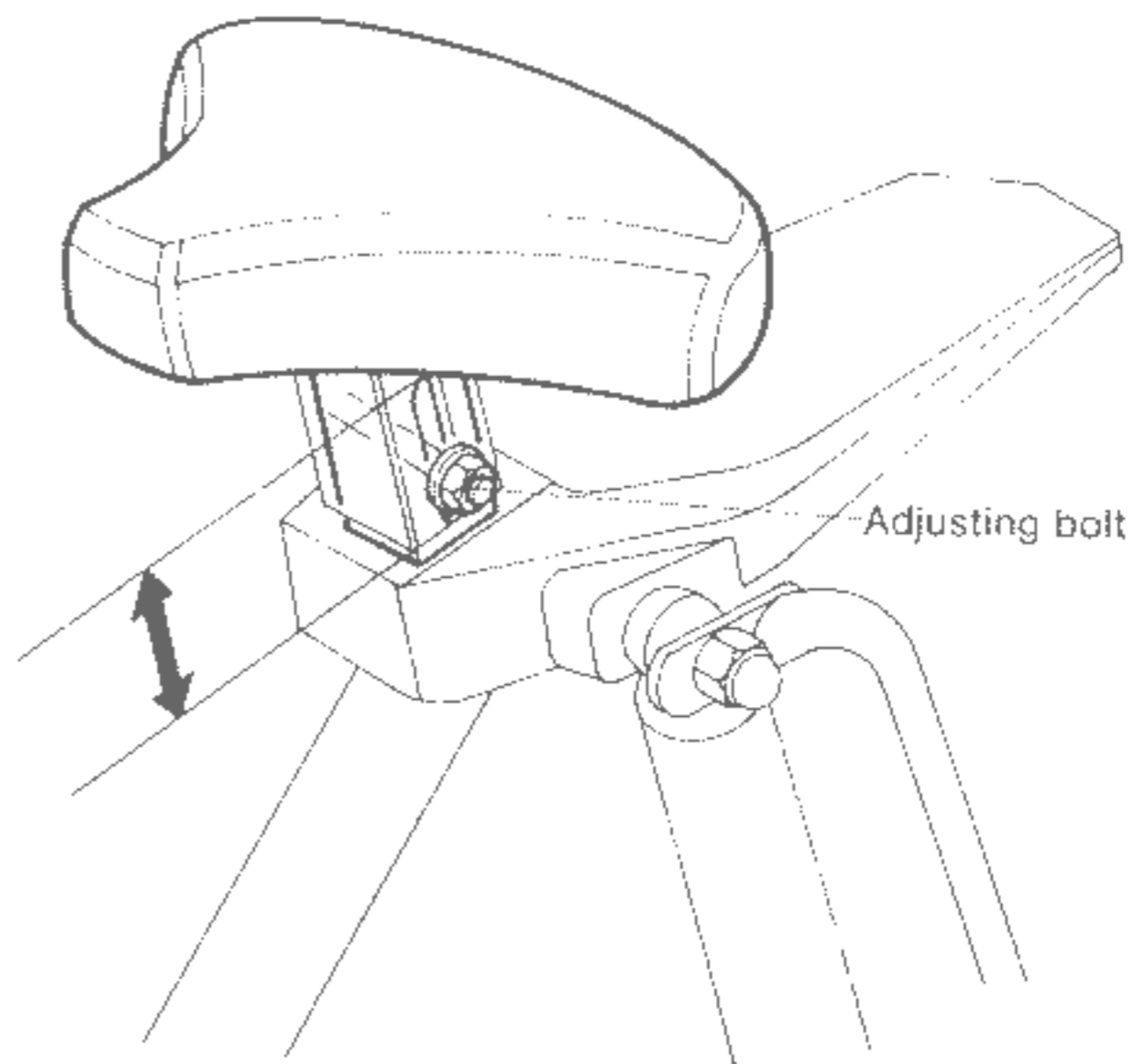

No adjustment possible.

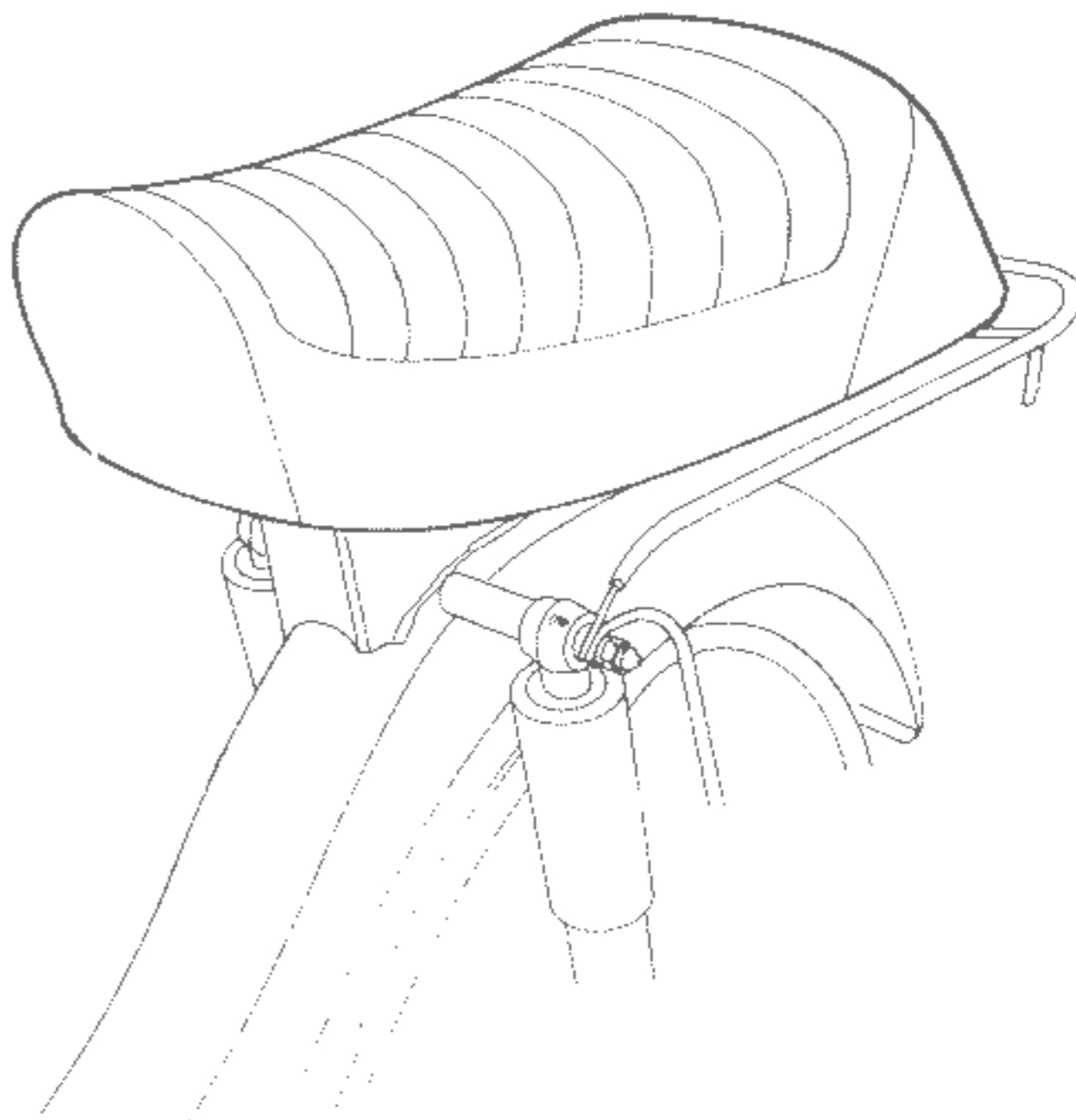
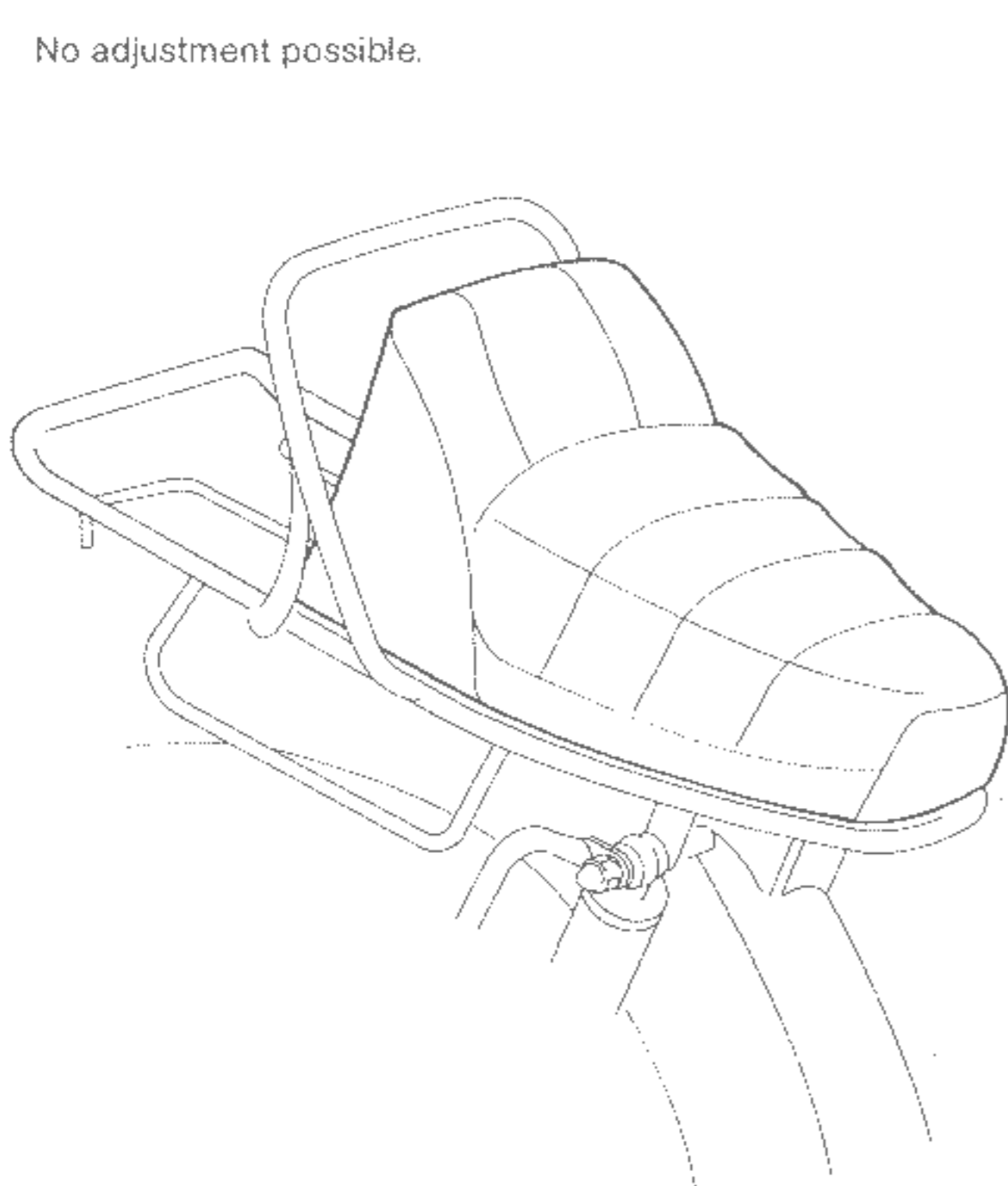



## 7. Brakes

Brake lever adjustment.

Check brake lever free play at lever tip. If out of specifications, adjust by turning adjusting nut.

● Rear

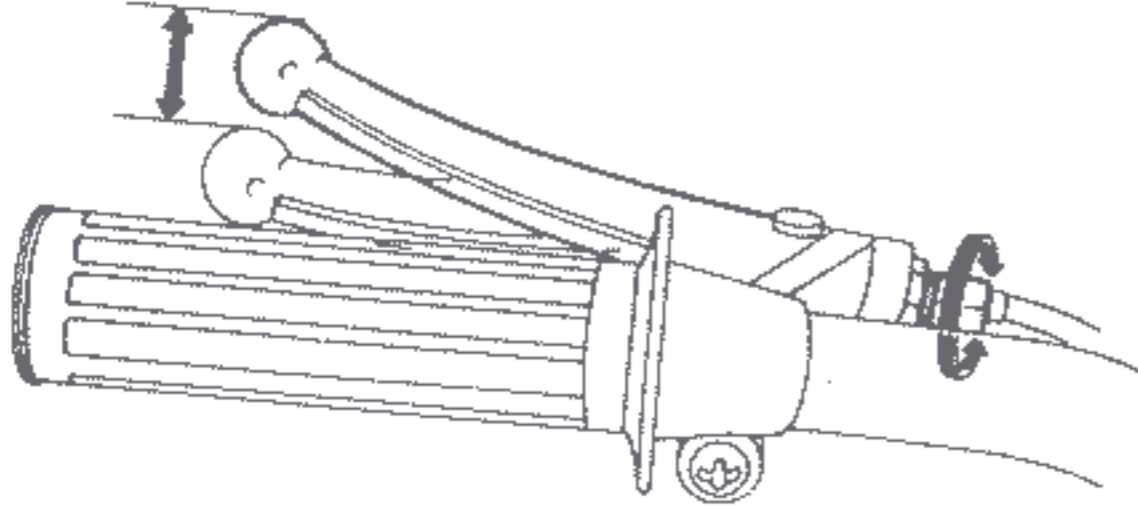

Front brake lever play (1)  
10-15 mm

● Front

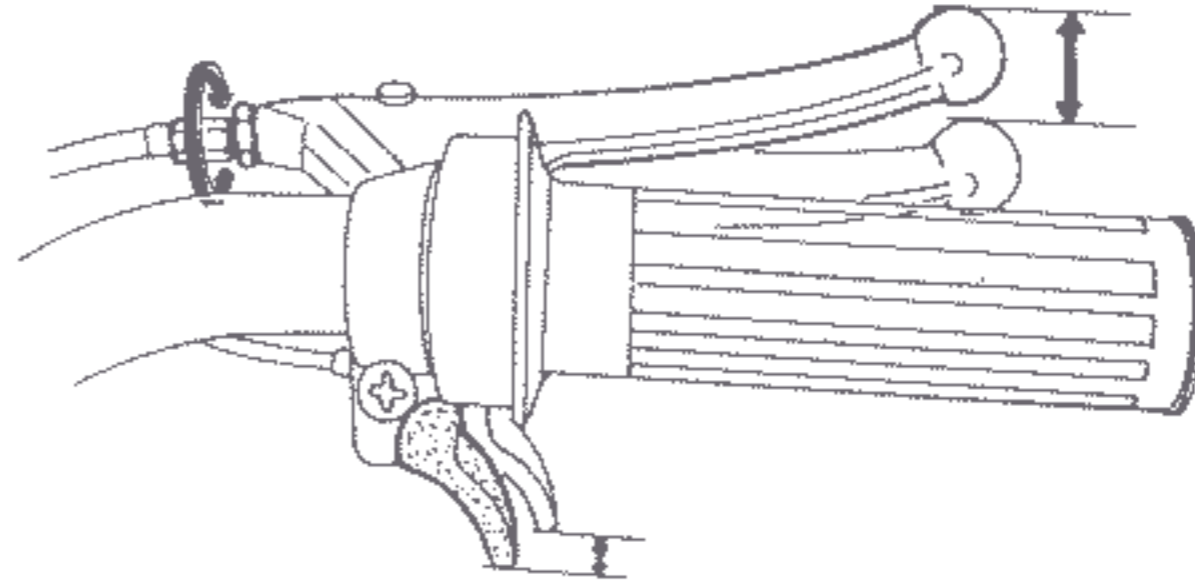

Rear brake lever play (2)  
10-15 mm



# HONDA PA50

## 5. ENGINE REMOVAL / INSTALLATION

REMOVE THE FRAME BODY FROM THE ENGINE IN THE FOLLOWING ORDER.

- ① Remove the floor cover (L/R)
- ② Remove the chain and belt covers
- ③ Turn the fuel valve lever to "Off" and disconnect the fuel hose.
- ④ Disconnect the lead connectors.
- ⑤ Disconnect the decompression cable.
- ⑥ Disconnect the plug cable
- ⑦ Disconnect the throttle cable.
- ⑧ Remove the rear brake cable end.
- ⑨ Remove the rear shock absorber bottom bolts.
- ⑩ Remove the engine hanger bolt

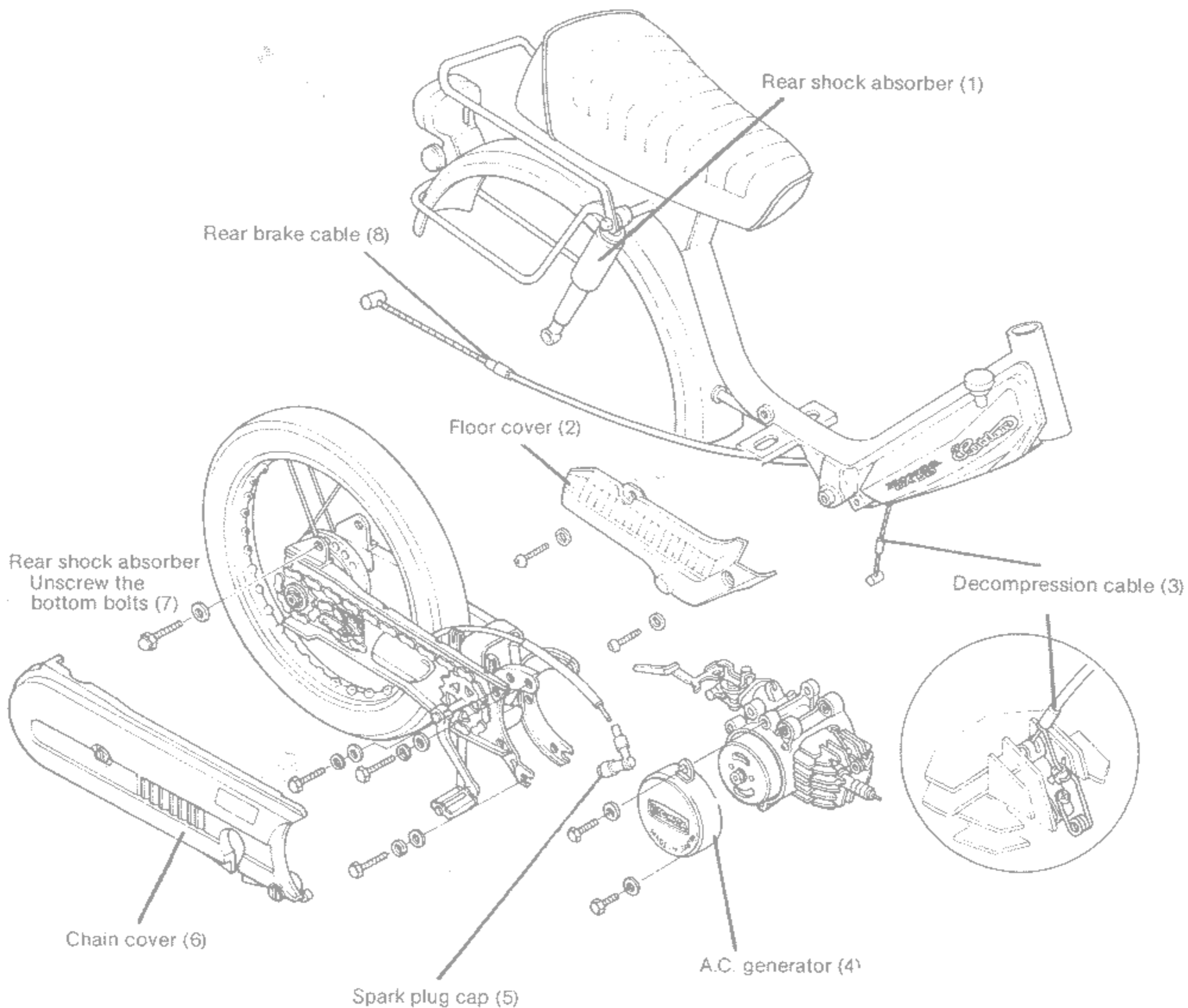
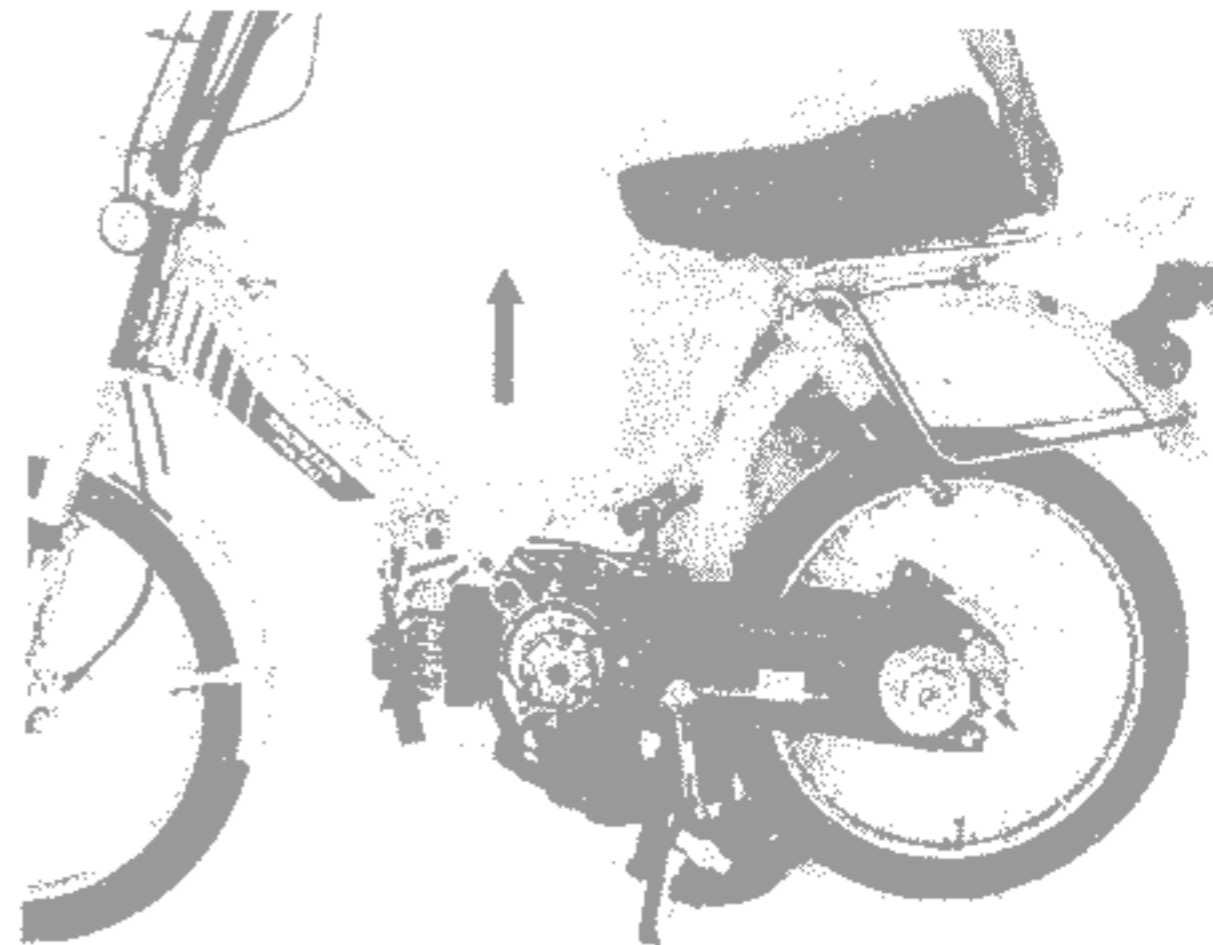



# HONDA PA50

● PULL THE ENGINE FORWARD AND AWAY FROM THE REAR FORK IN THE FOLLOWING ORDER.

- 1 Loosen the four rear fork bolts and move the rear wheel forward
- 2 Remove the drive belt
- 3 Remove the muffler
- 4 Remove the engine mounting bolts

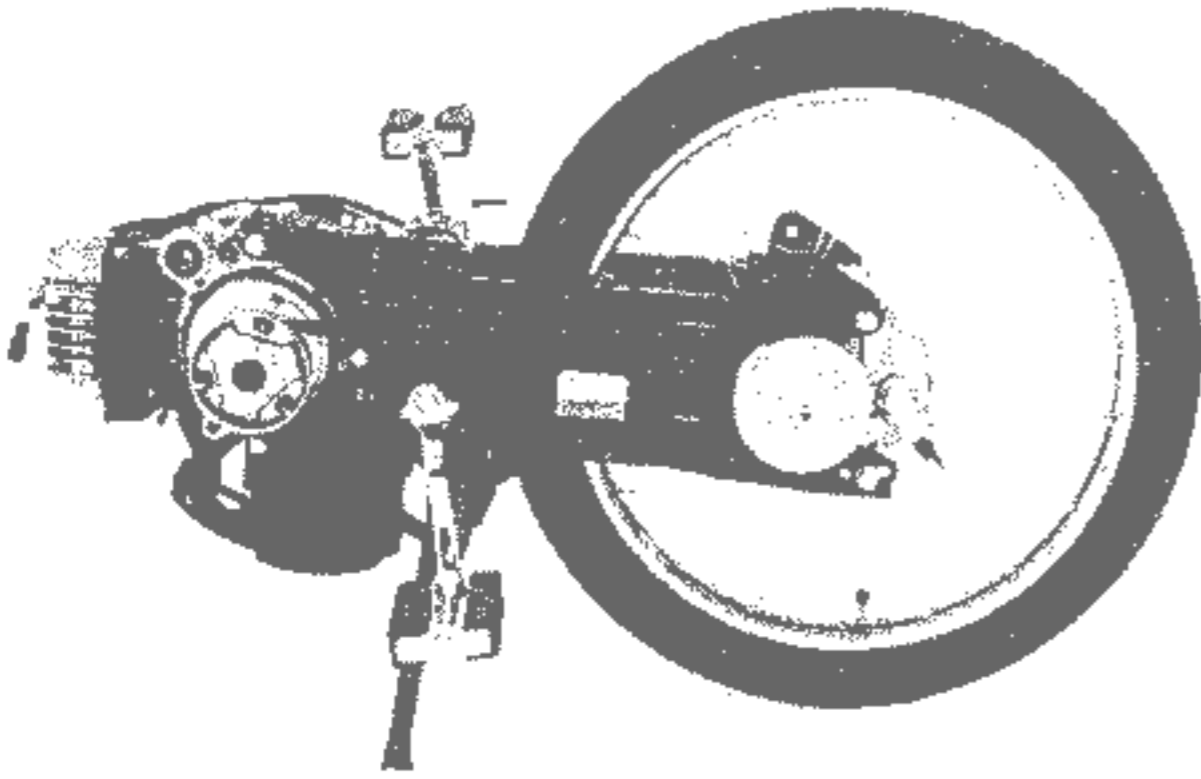

**NOTE:**  
Connect color-to-color (\*)

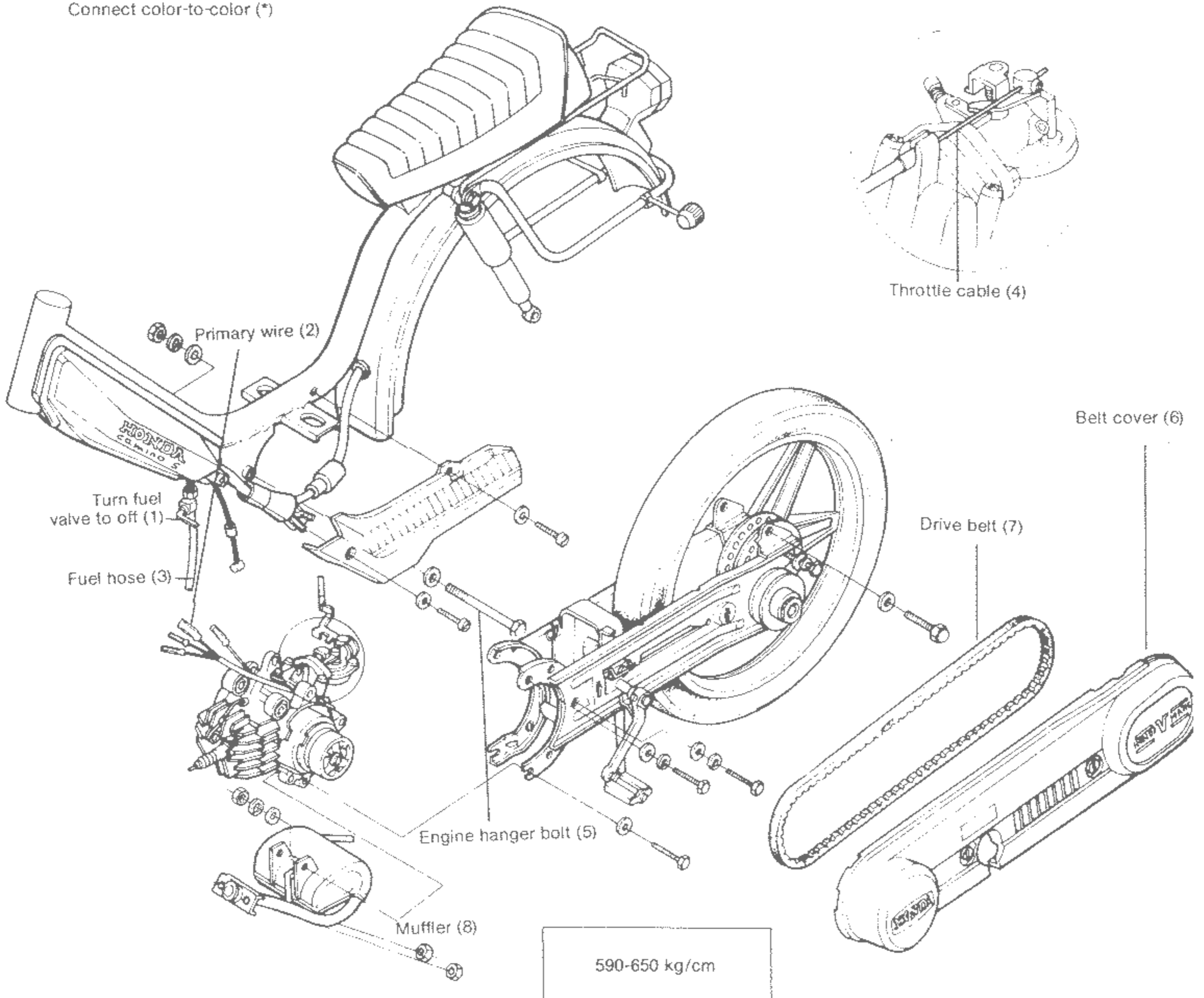





# HONDA PA50

## 6. CYLINDER HEAD / CYLINDER / PISTON

|                                 |    |
|---------------------------------|----|
| A. Trouble shooting .....       | 45 |
| B. Disassembly / Assembly ..... | 47 |
| C. Inspection .....             | 48 |
| D. Testing compression .....    | 51 |

### A. Trouble shooting

| Symptom                   | Probable cause  |
|---------------------------|---|
| No or loss of compression | Poorly tightened spark plug<br>Blown cylinder head gasket<br>Worn or seized piston rings<br>Damaged cylinder or piston<br>Defective reed valve<br>Decompression valve not seating correctly |
| Overheating               | Excessive carbon in combustion chamber<br>Excessive carbon on piston or piston rings  |
| Piston clearance          | Worn cylinder wall<br>Worn cylinder or piston<br>Worn piston pin<br>Worn connecting rod big end bearing   |
| Excessive smoke           | Worn or seized piston rings<br>Excessive carbon in combustion chamber<br>Worn cylinder or piston  |
| Excessive compression     | Excessive carbon in combustion chamber<br>Excessive carbon on piston or piston rings  |



# HONDA PA50

## Removal/Installation

- 1 Disconnect the decompression cable and plug cap at the cylinder head.
- 2 Remove the two 6 mm nuts, loosen the two lower engine mounting bolts, and remove the muffler.

**NOTE:** Set the shift lever to pedal driving position

### PISTON PIN CLIP (5)

**Note**  
During assembly, install new pin clip.

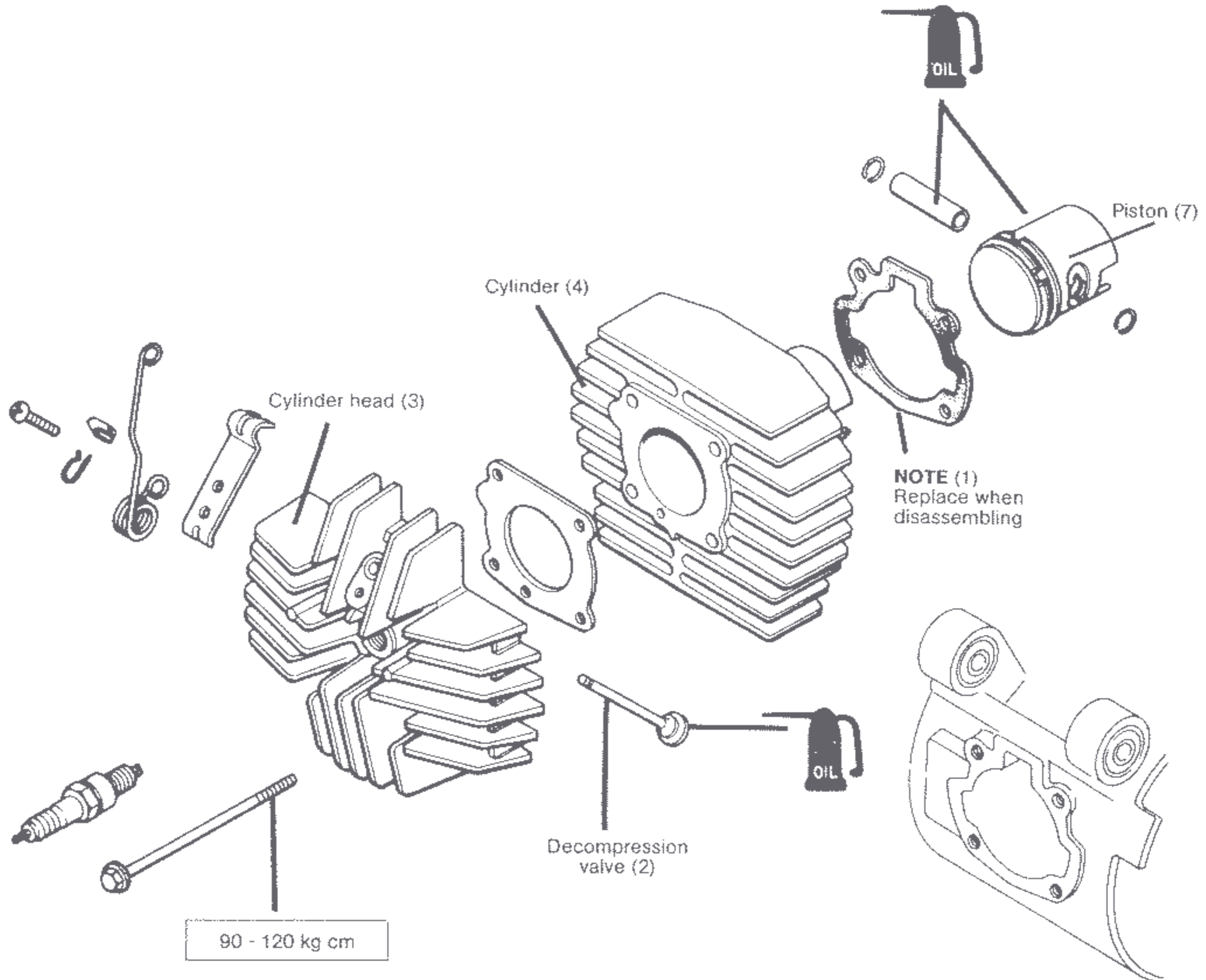

### PISTON RING (6)

**NOTE**  
Install the cylinder with the piston ring gaps fitted to the piston ring dowels

## B. Disassembly/Assembly

Install piston pin with the "EX" facing the EXHAUST PORT

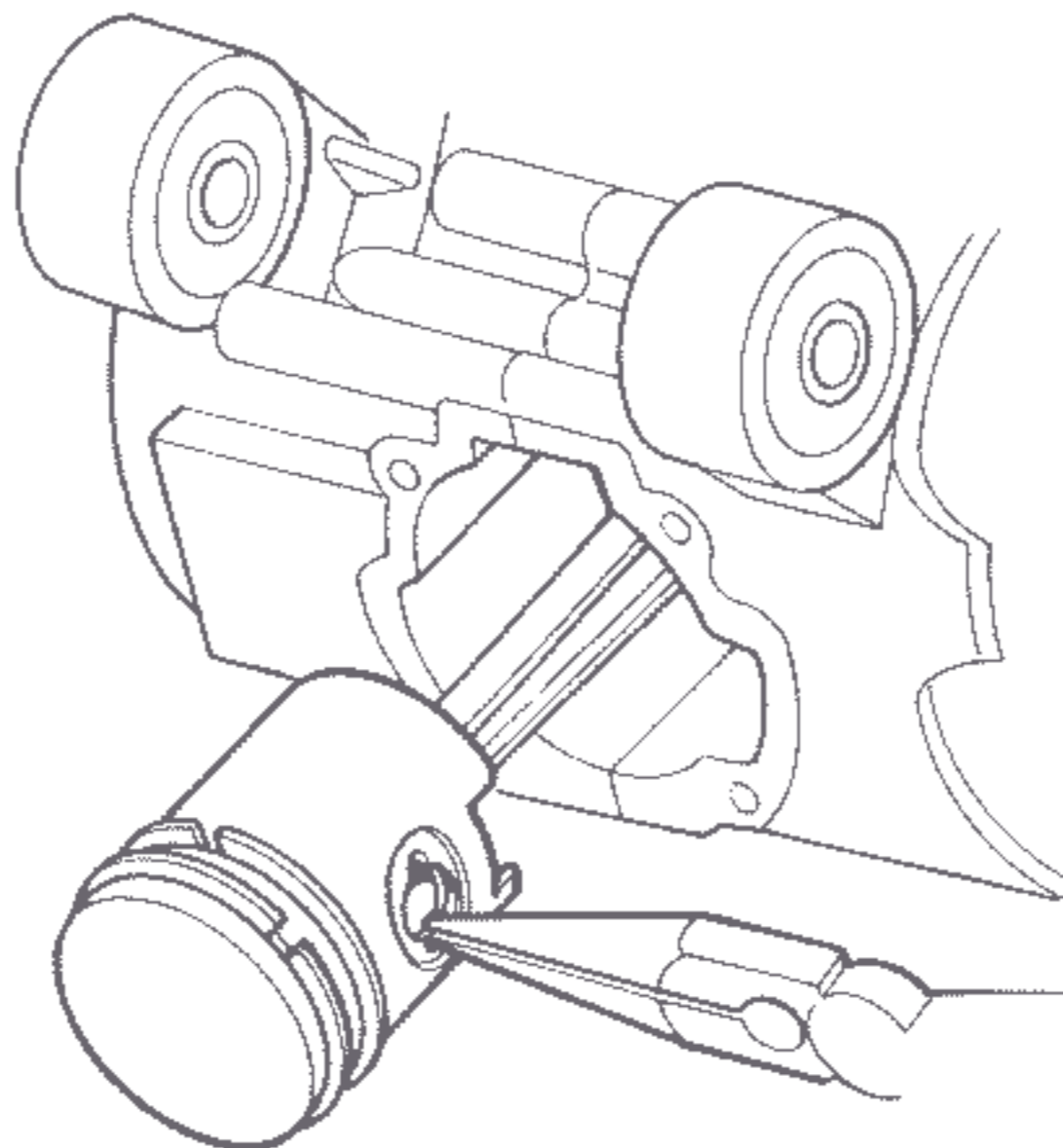

**NOTE:**  
Avoid scoring or scratching  
the piston

### ● Piston Ring DISASSEMBLY/ASSEMBLY

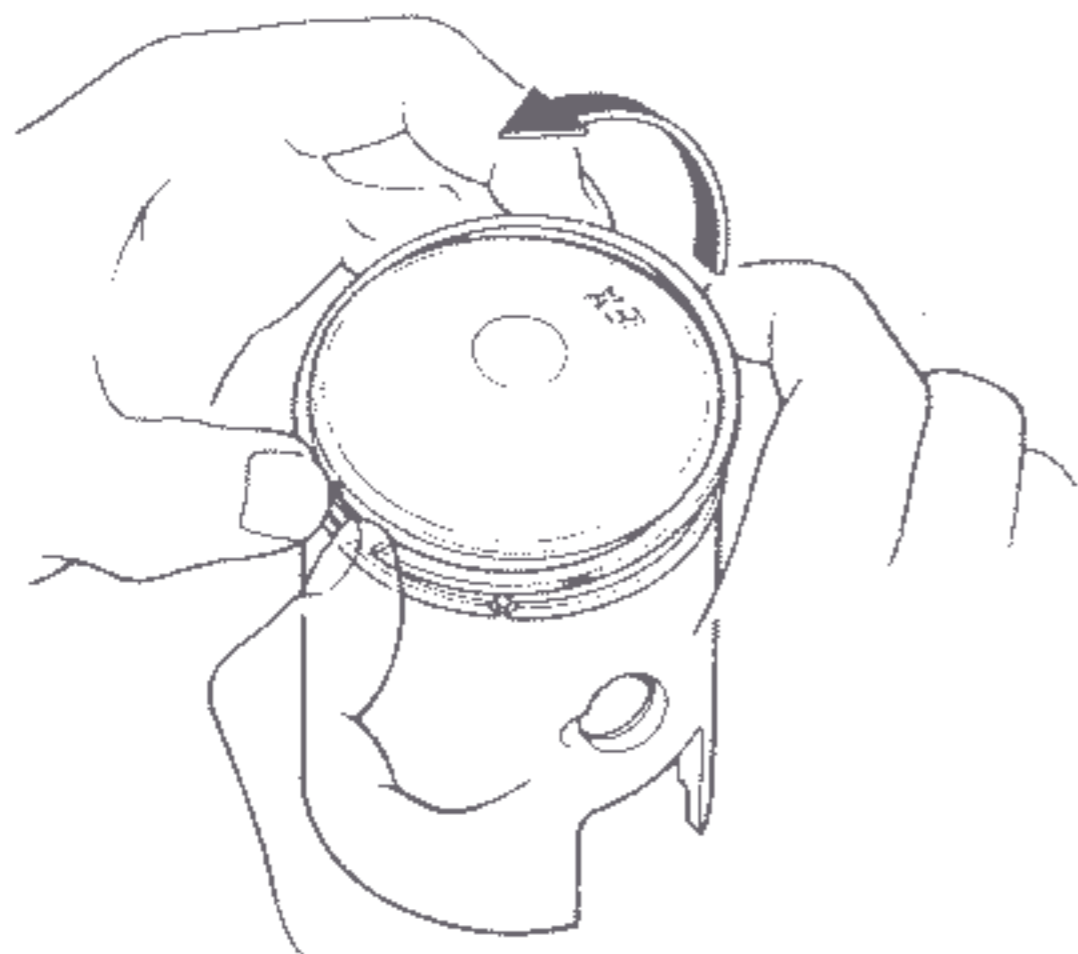

Always remove piston ring by lifting in  
the direction of the arrow.

Do not damage the piston rings

### ● ASSEMBLY

Install the piston rings with their markings facing up.  
When replacing the rings, ensure that the proper rings are  
installed

N: Nippon  
T: Teikoku  
1 = 1N or 1T  
2 = 2N or 2T

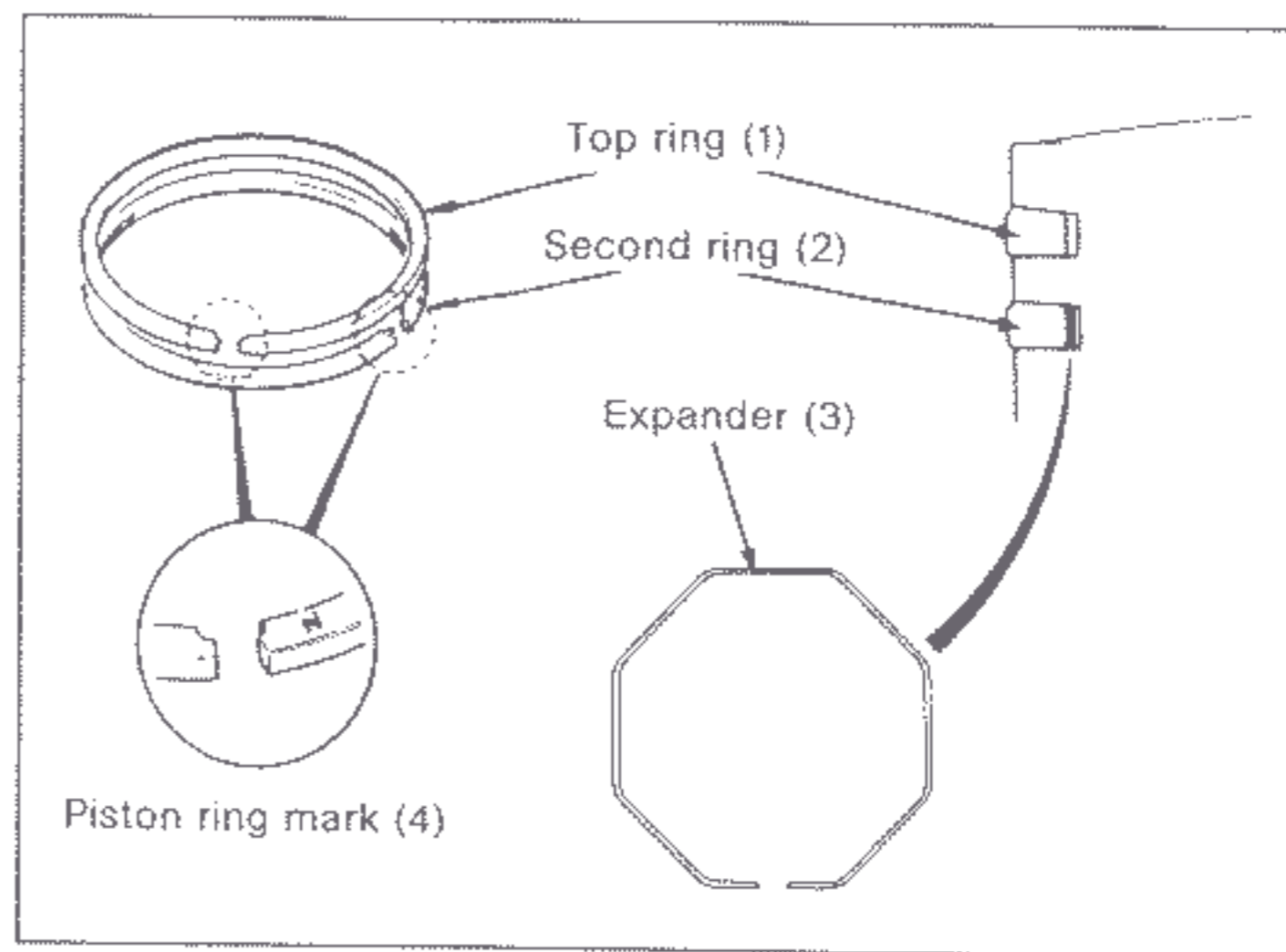

**NOTE:**  
Do not mix the top and second ring. Use the piston rings  
of the same manufacturer in a set.



# HONDA PA50

## C. Inspection

### ● Cylinder head DECARBONIZING

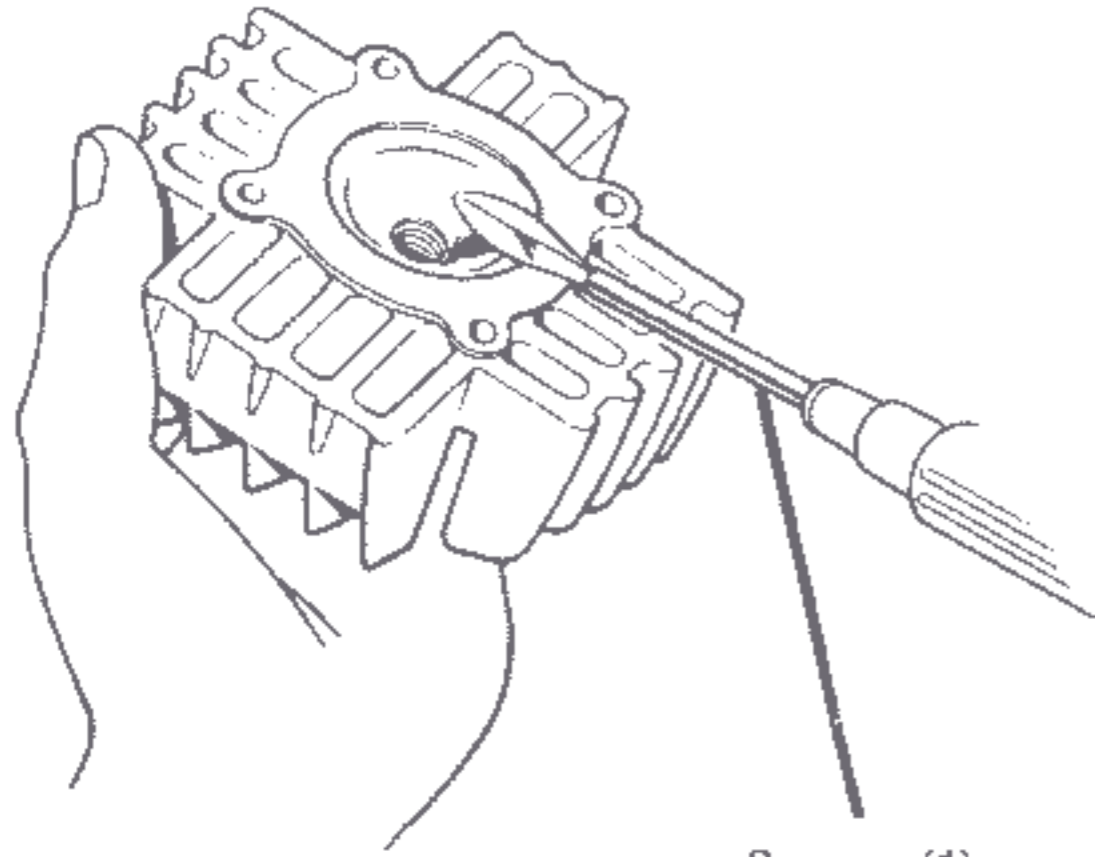

Scraper (1)

### (Exhaust port. DECARBONIZING)

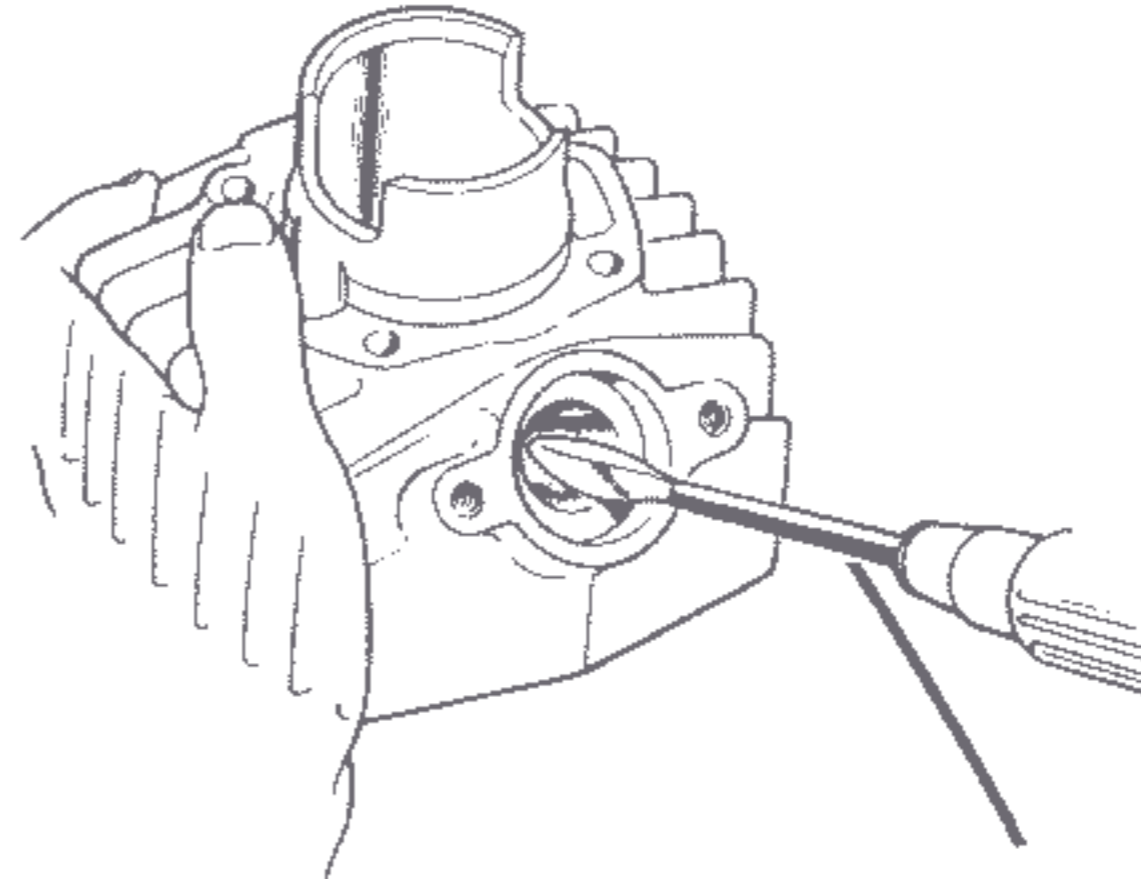

Scraper (1)

Avoid scratching side surface.  
clean after decarbonizing

Clean after decarbonizing

### ● Cylinder I.D.

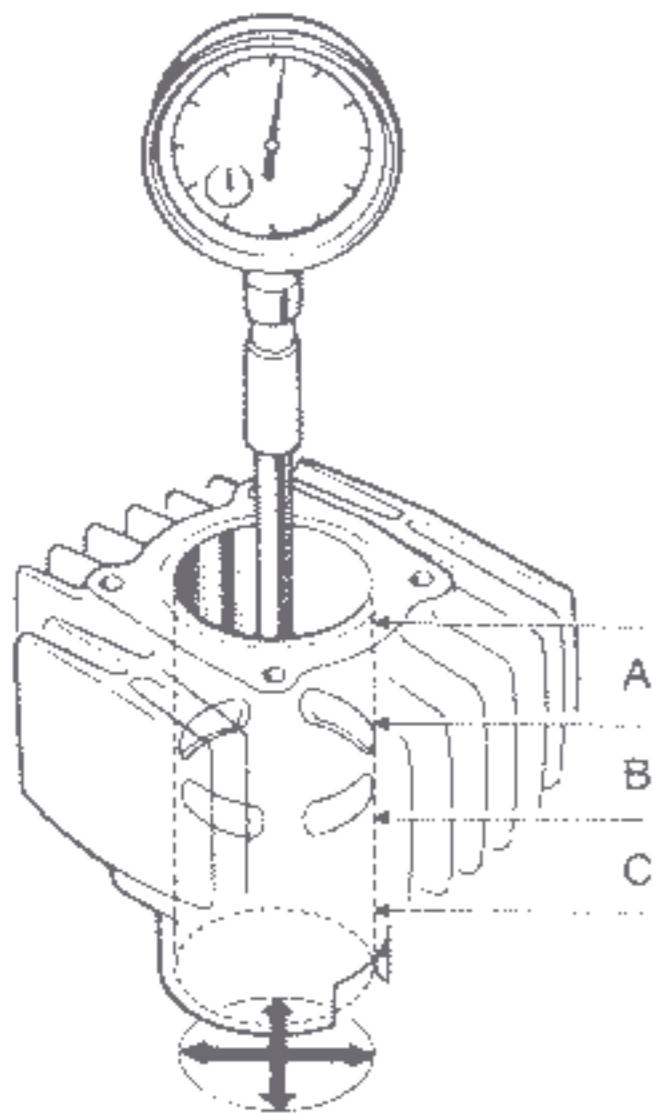

Take smallest  
diameter reading

Measure in all three positions shown

|   | Standard        | Service limit |
|---|-----------------|---------------|
| A | 40.000 - 40.020 | 40.05 mm      |
| B | 40.000 - 40.020 | 40.05 mm      |
| C | 40.000 - 40.020 | 40.05 mm      |

Measure positions as below

| Position | Distance from face of gasket |
|----------|------------------------------|
| A        | 0.35 mm                      |
| B        | 35 - 75 mm                   |
| C        | 75 - 88 mm                   |



● Piston skirt O.D.

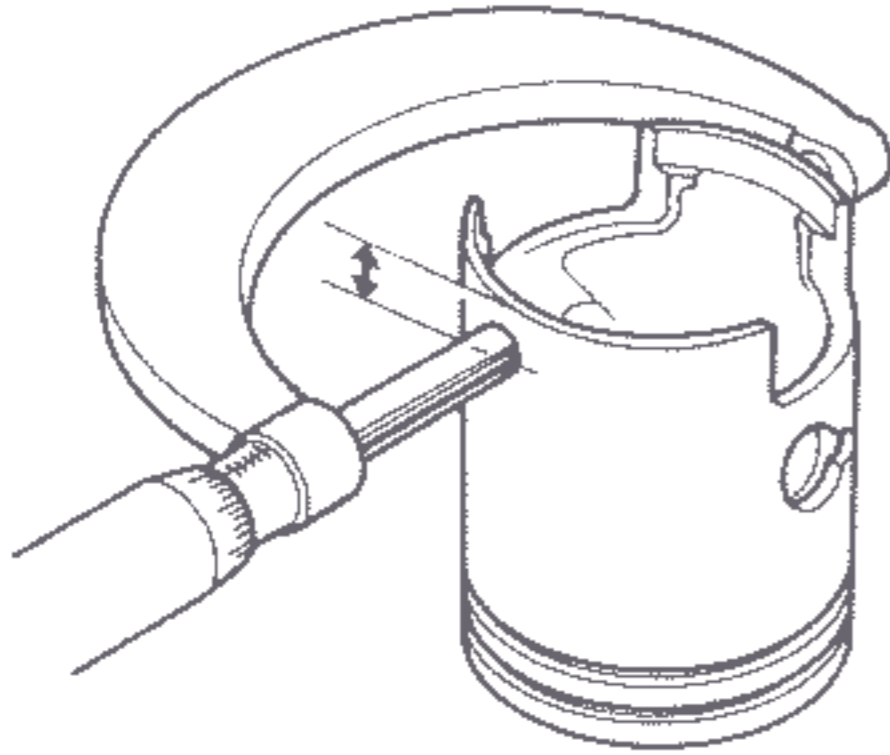

Measurement should be taken at a point 4 mm from bottom

| Standard        | Service Limit |
|-----------------|---------------|
| 39.955 - 39.975 | 39.85 mm      |

● Piston Ring side Clearance

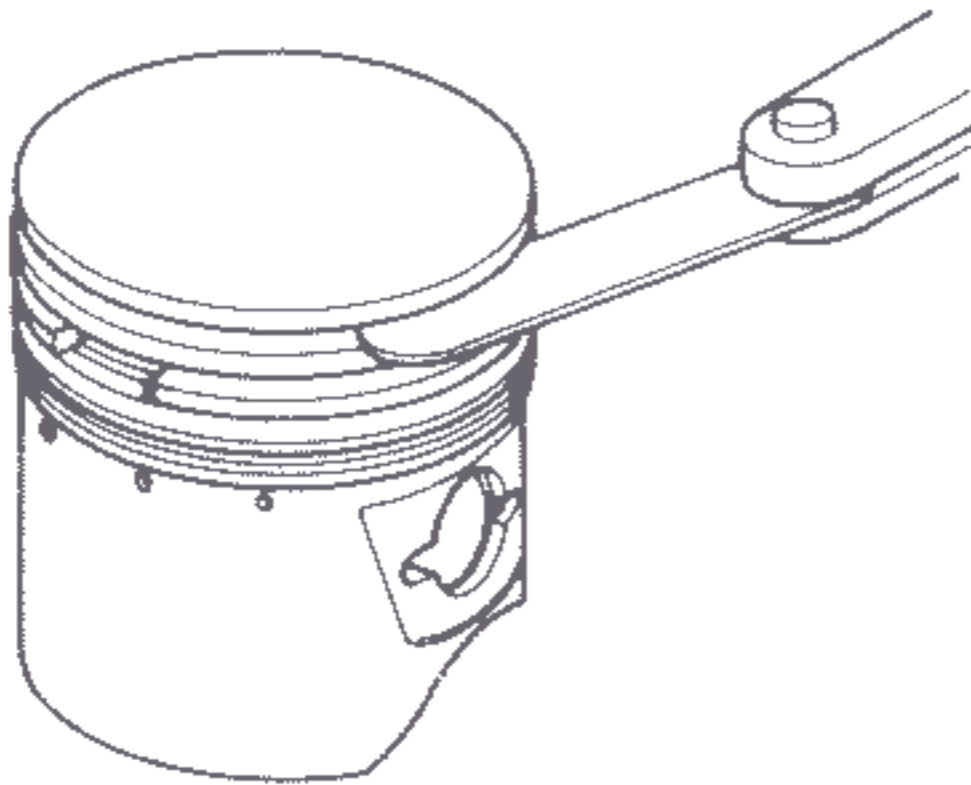

2nd Rings

| Standard      | Service Limit |
|---------------|---------------|
| 0.025 - 0.055 | 0.1 mm        |

● Piston Ring Thickness

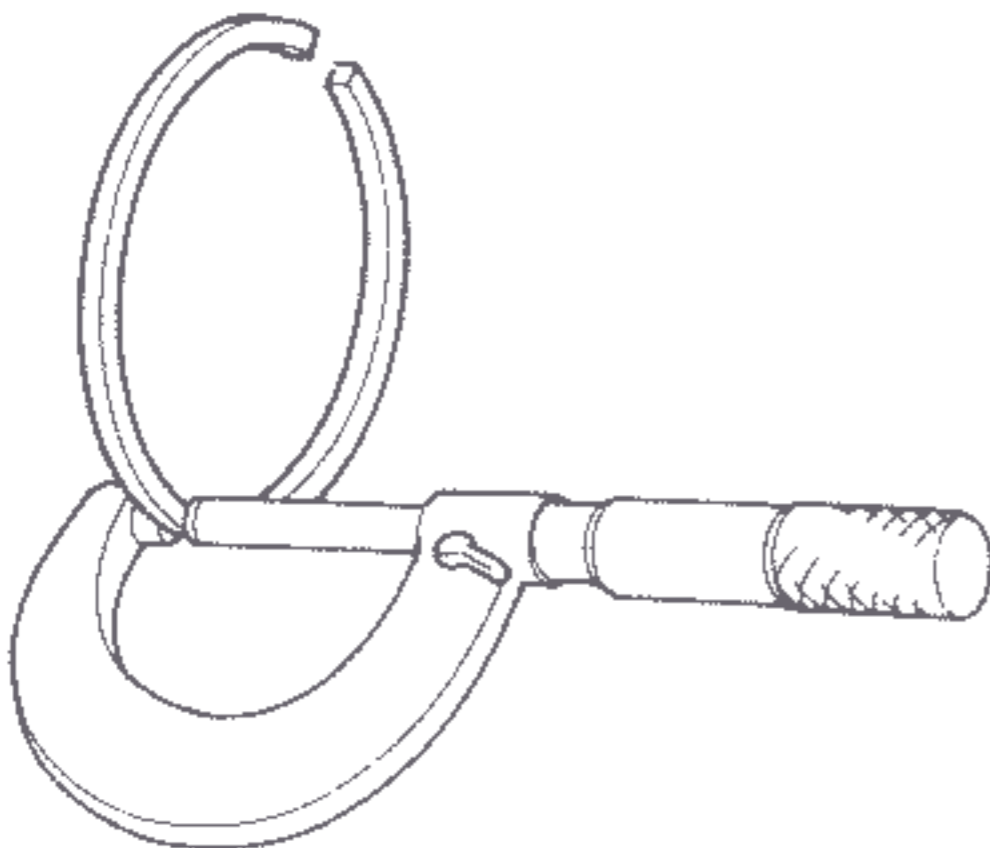

|     | Standard       | Service Limit |
|-----|----------------|---------------|
| 2nd | 1.4975 - 1.499 | 1.43 mm       |



# HONDA PA50

## ● Piston Ring end Gap

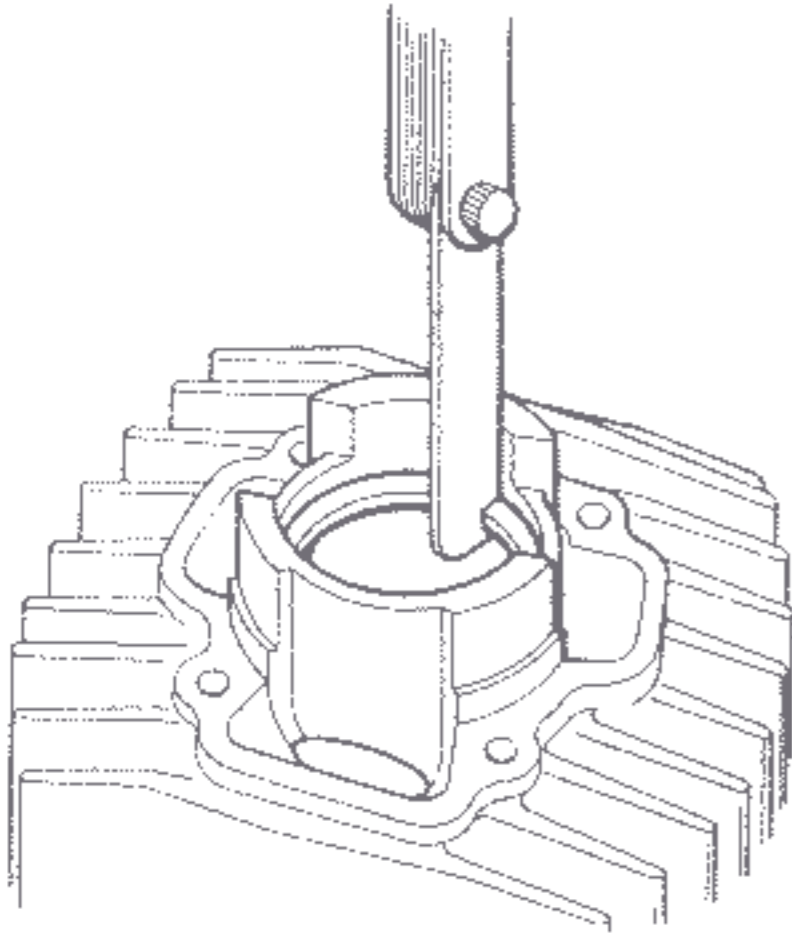

### Both Top/2nd Rings

| Standard    | Service Limit |
|-------------|---------------|
| 0.15 - 0.35 | 0.6 mm        |

## ● Piston Pin O.D.

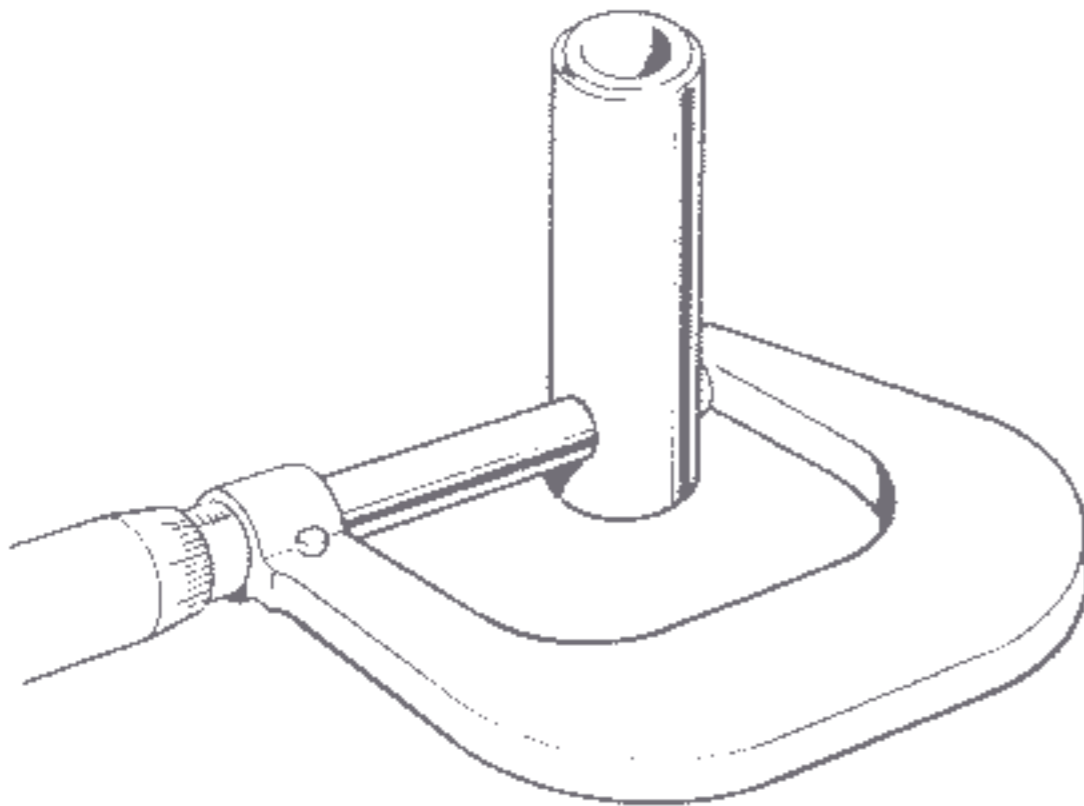

| Standard       | Service Limit |
|----------------|---------------|
| 9.994 - 10.000 | 9.97 mm       |

## ● Piston Pin Hole I.D.

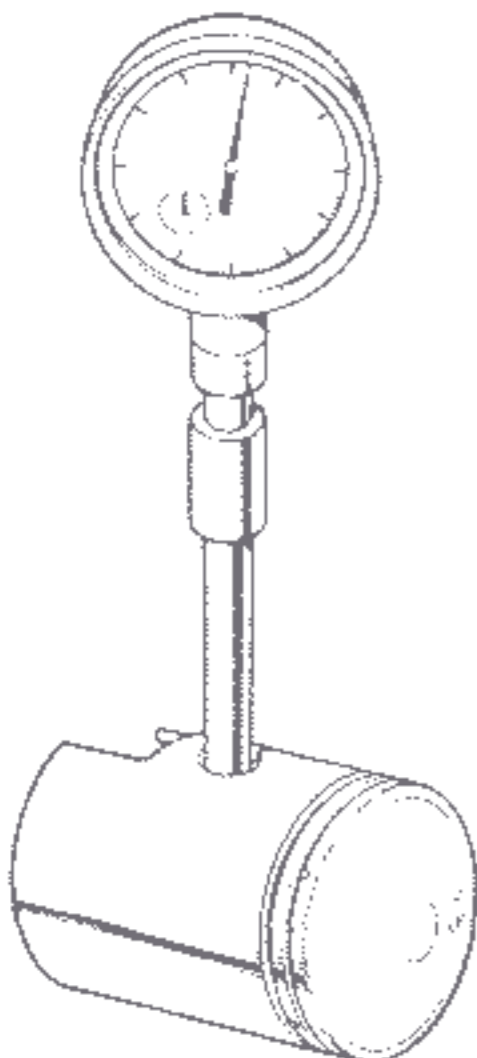

| Standard        | Service Limit |
|-----------------|---------------|
| 10.002 - 10.008 | 10.03 mm      |



# HONDA<sup>®</sup> PA50

## D. Compression

- ① Warm up the engine until normal operating temperature is reached
- ② Remove the spark plug
- ③ Set compression gauge in the spark plug hole
- ④ Turn the throttle grip fully open
- ⑤ Crank the pedals until the gauge needle reaches the highest point

|                           |
|---------------------------|
| Compression               |
| 8 - 12 kg cm <sup>2</sup> |

Throttle grip (1)

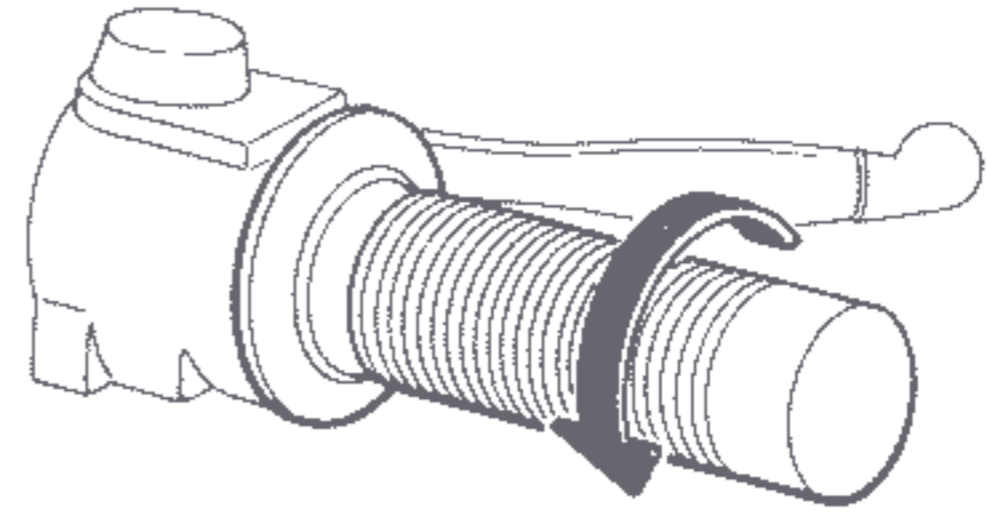

Fully open (2)

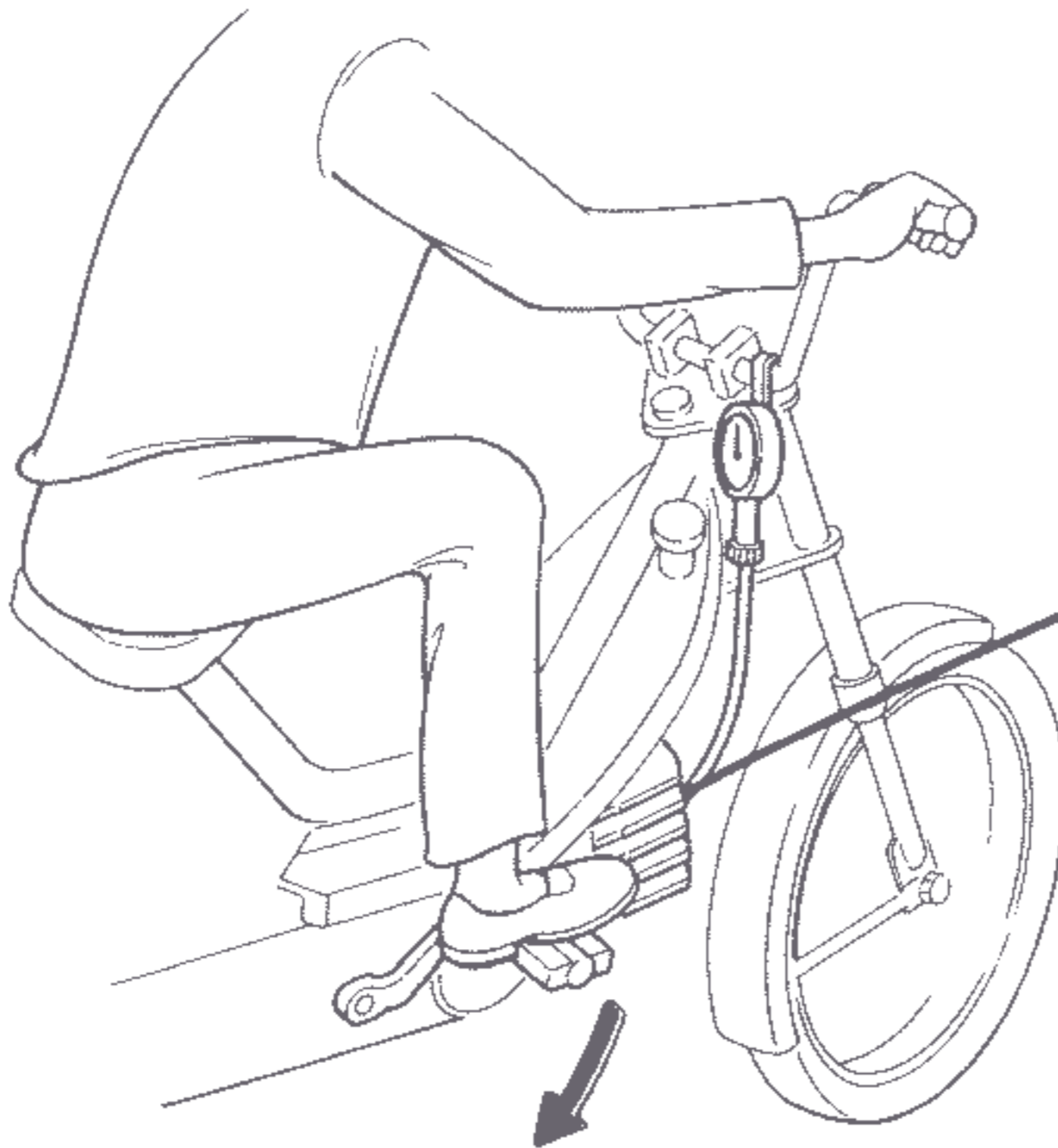

### NOTE

Tighten securely to prevent leaks



## 7. A.C. GENERATOR

### A. Disassembly/Assembly

- ① Remove the right floor cover
- ② Remove the chain cover

During assembly and installation, make sure that no foreign particles have adhered to the magnet inside of the flywheel.

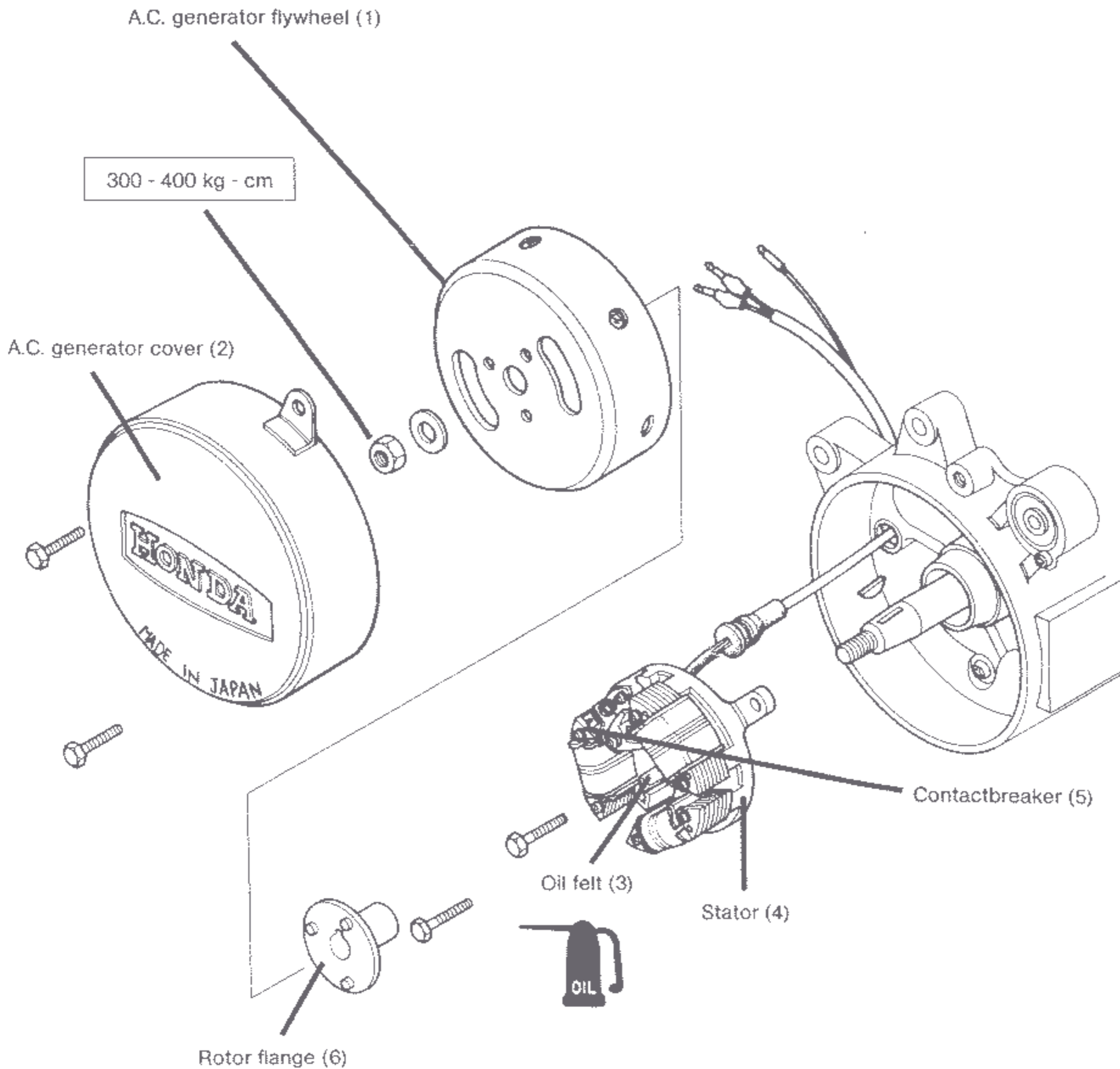

**NOTE:**  
Prior to installation, route the A.C. generator cable through the hole in the case





### ● Flywheel Disassembly/Assembly

Holder flywheel  
07925-0010001

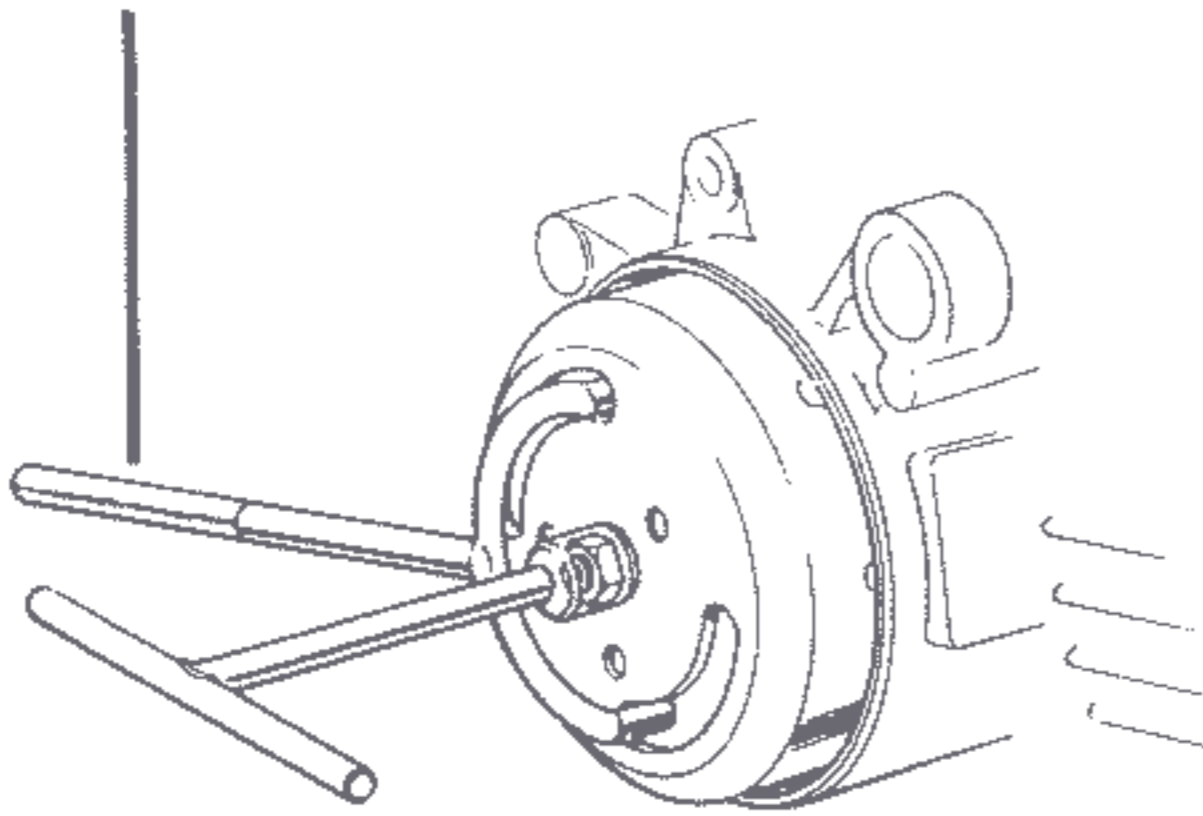

### ● Rotor Flange Disassembly

Cam Puller  
07934-1480000

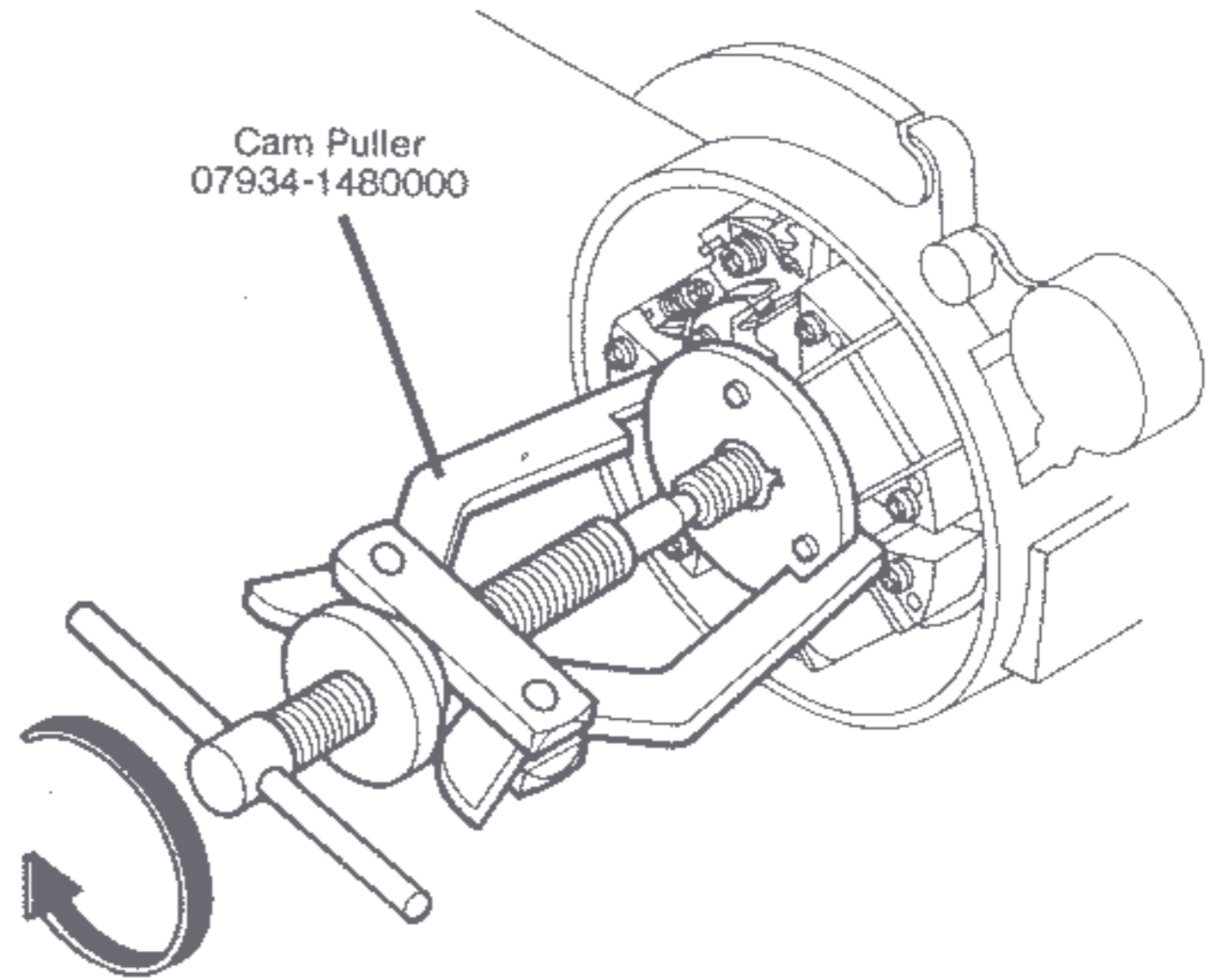

### ● Rotor Flange installation

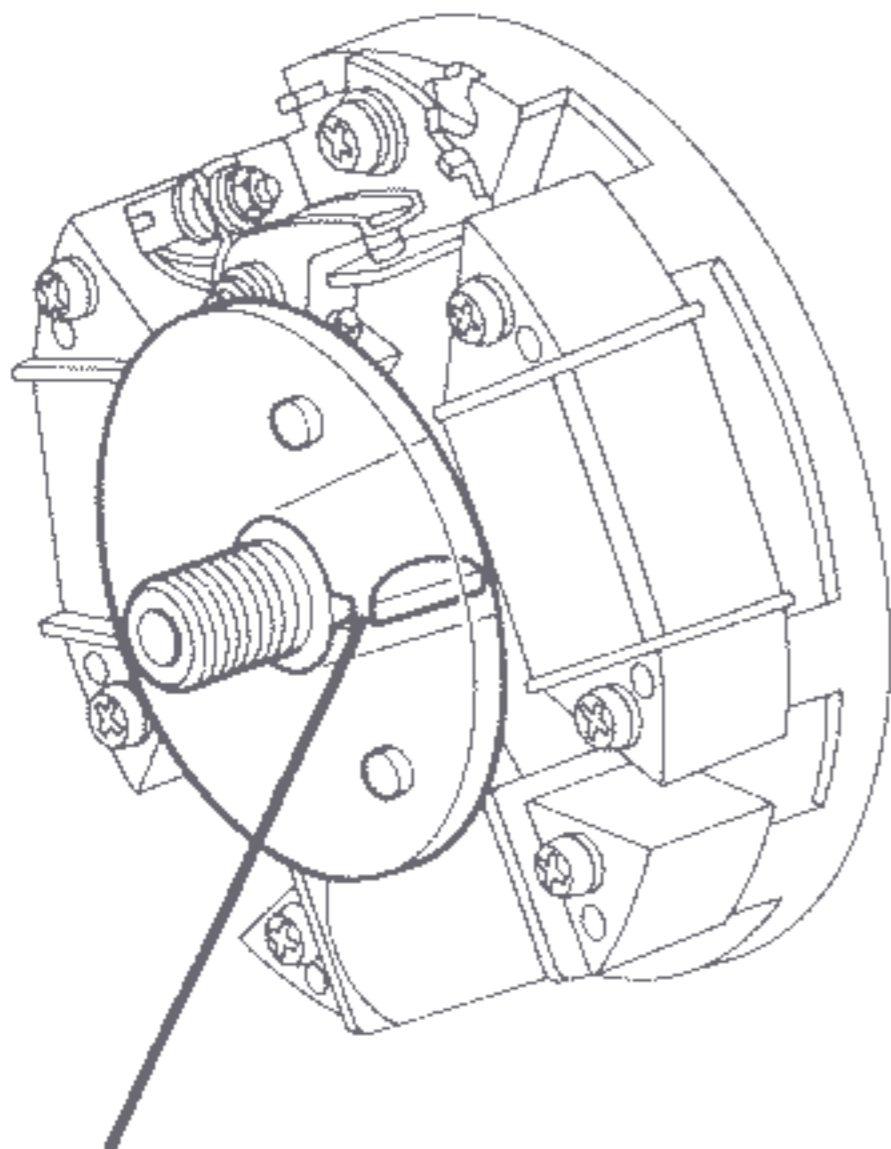

Align the key with the keyway

### ● Contact Breaker Disassembly

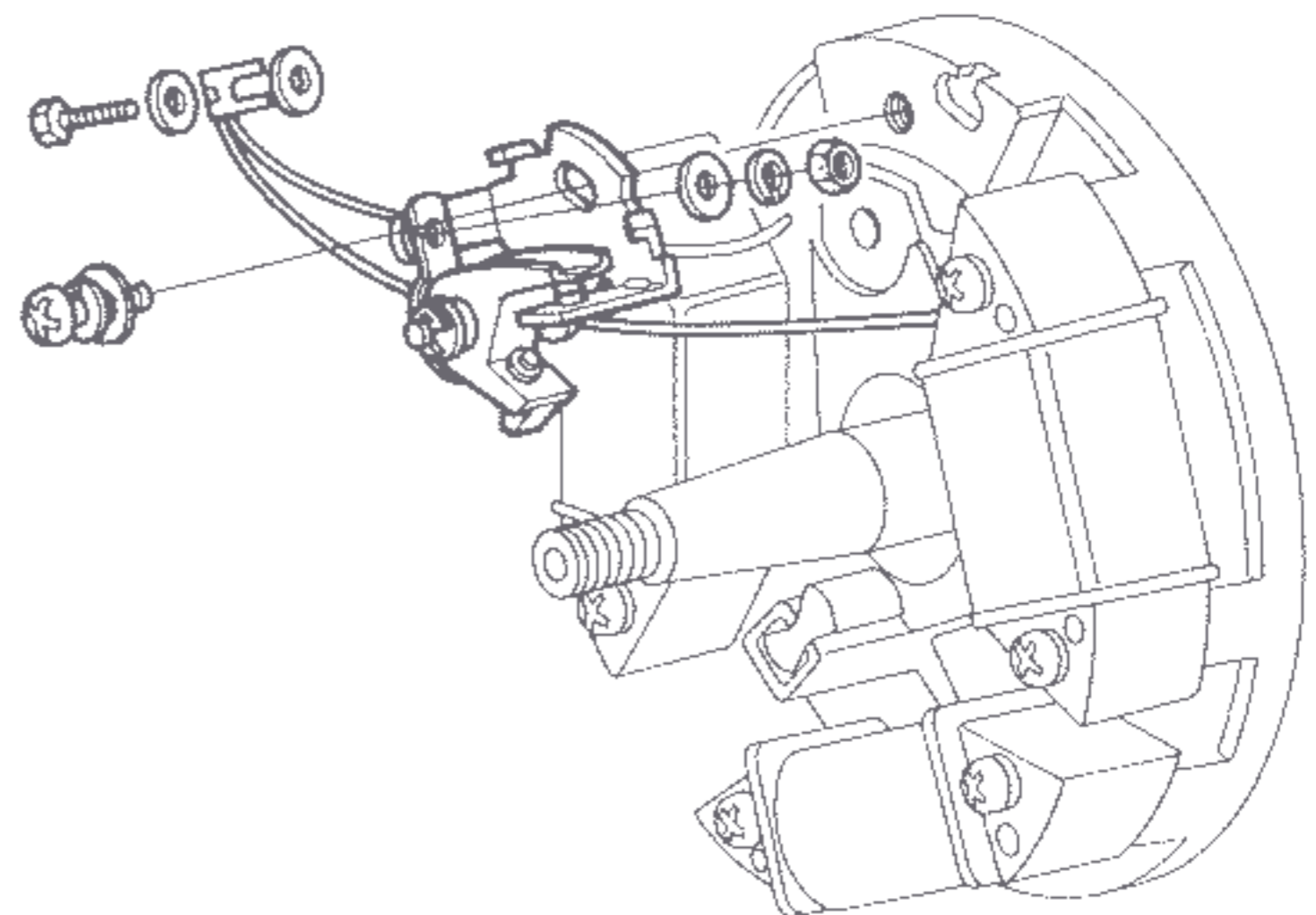

After assembling, adjust contact breaker point gap and  
ignition timing



## B. Inspection

- Contact breaker point

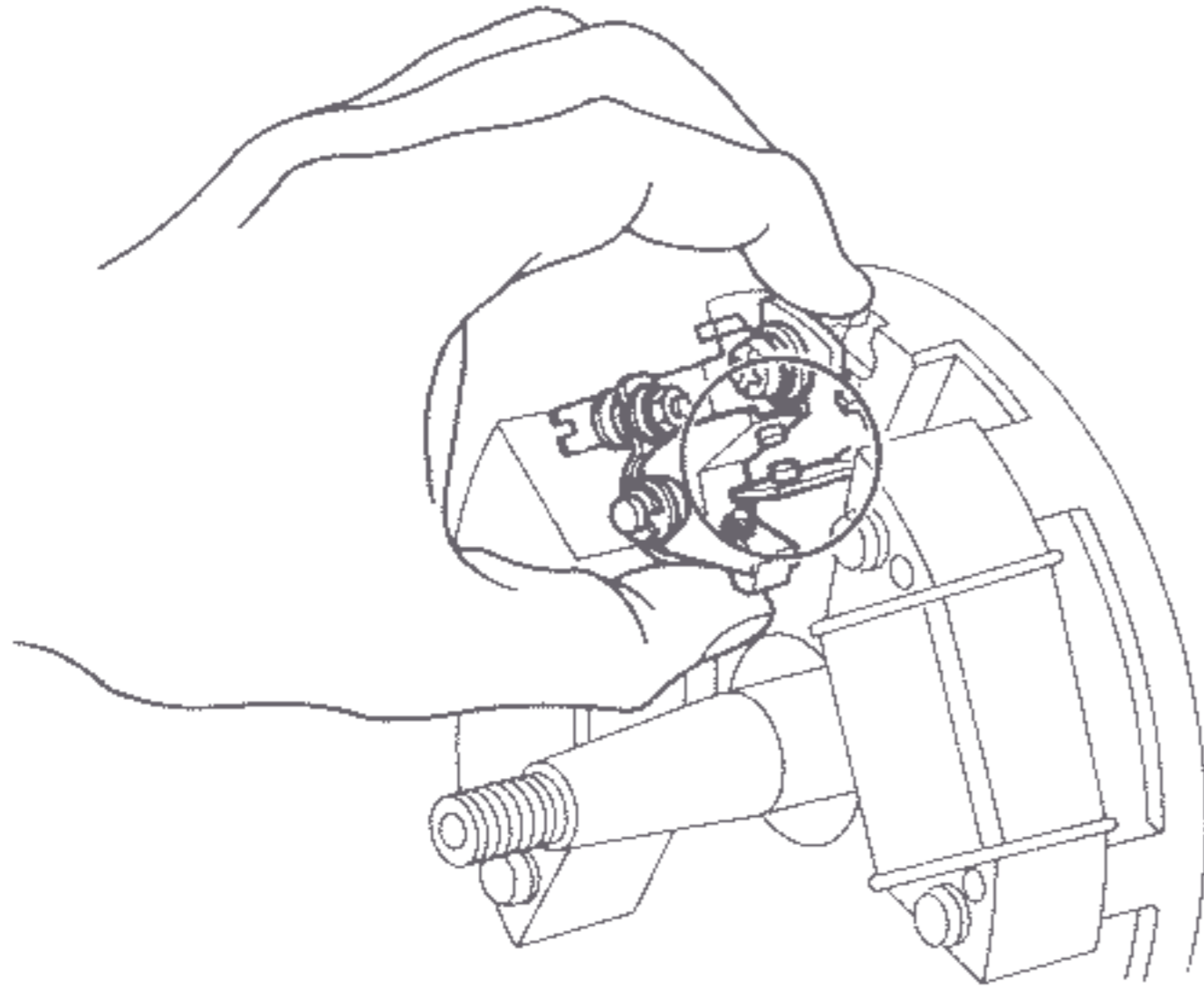

Point gap

standard; 0,3 - 0,4 mm

Normal (1)

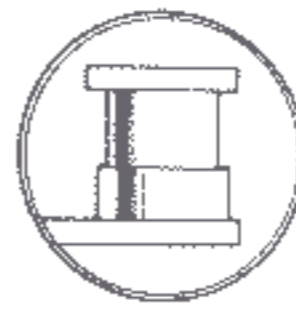

No good (2) X



Worn (3)



Out of alignment (4)



Fouled (5)



Metaltransfer (6)



## 8. DRIVE PULLEY/CLUTCH/DRIVEN PULLEY

|                               |    |
|-------------------------------|----|
| A. Trouble shooting .....     | 55 |
| B. Disassembly/Assembly ..... | 56 |
| C. Inspection .....           | 60 |

### A. Trouble shooting

| Symptom                                 | Probable cause                                       |
|---|--|
| Power not transmitted to the rear wheel | Worn damaged drive clutch linings                    |
| Poor performances at high speed         | Worn weight sleeve.<br>Deffective movable drive face |
| Lack of power                           | Defective torque of driven pulley                    |



# HONDA PA50

## B. Disassembly/Assembly

Set the shift lever at pedal drive position

- ① Remove the drive belt cover
- ② Remove the drive belt cover

Never start the engine with the drive pulley removed. The crankcase will be scratched by the centrifugal drive clutch weights

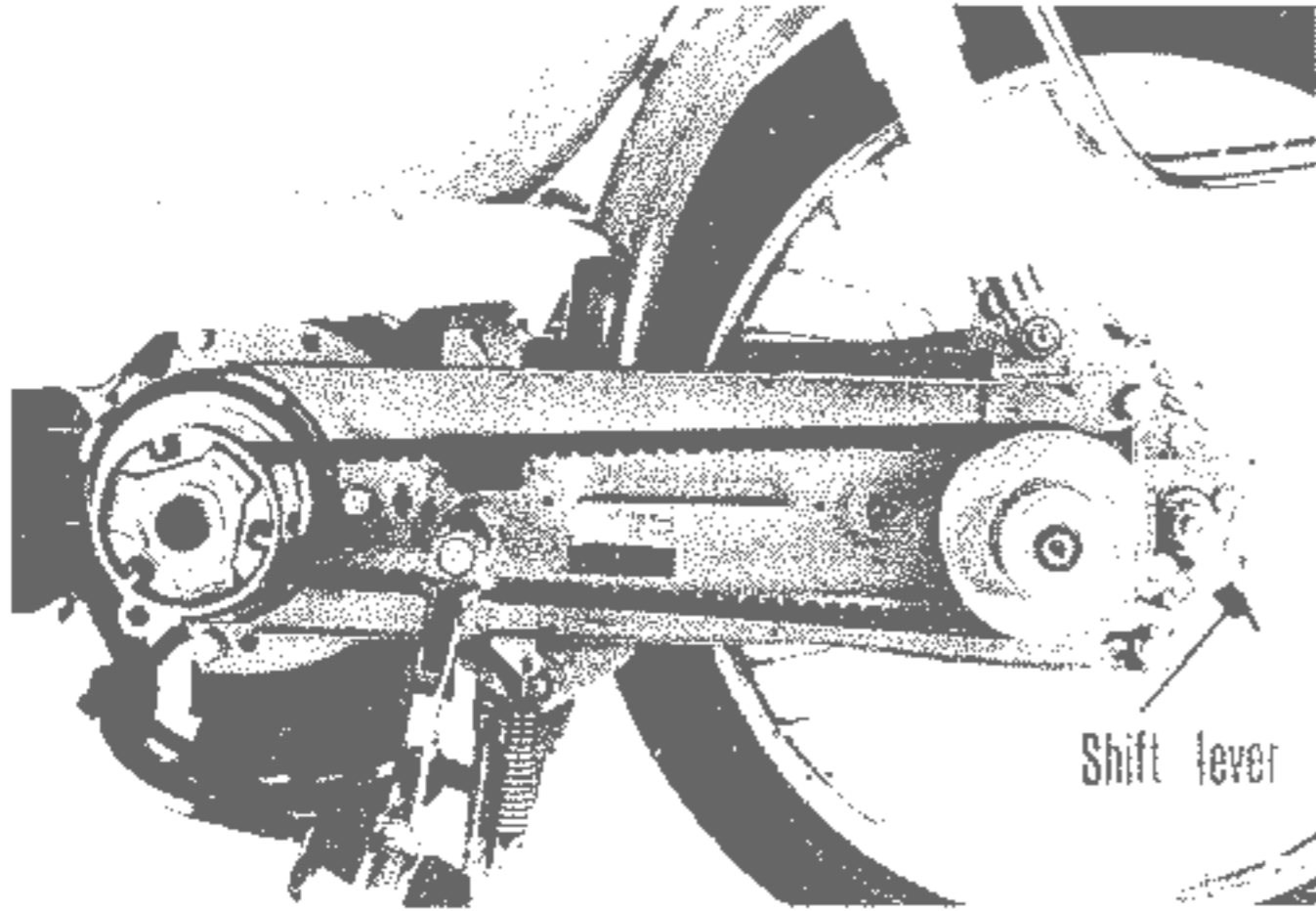

Avoid getting grease or oil on belt or pulley surfaces

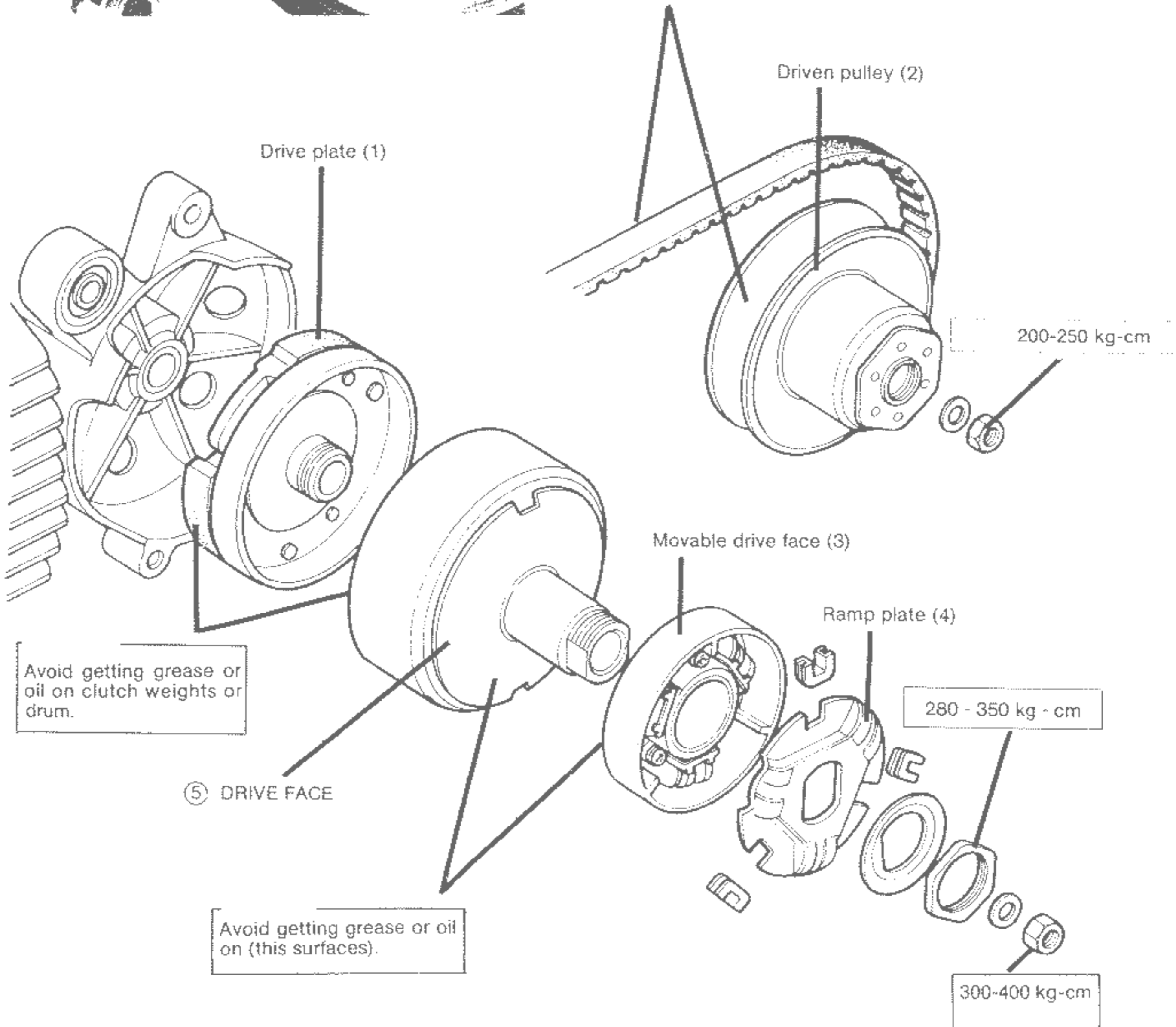



## Disassembly/Assembly

● Drive pulley attaching nut

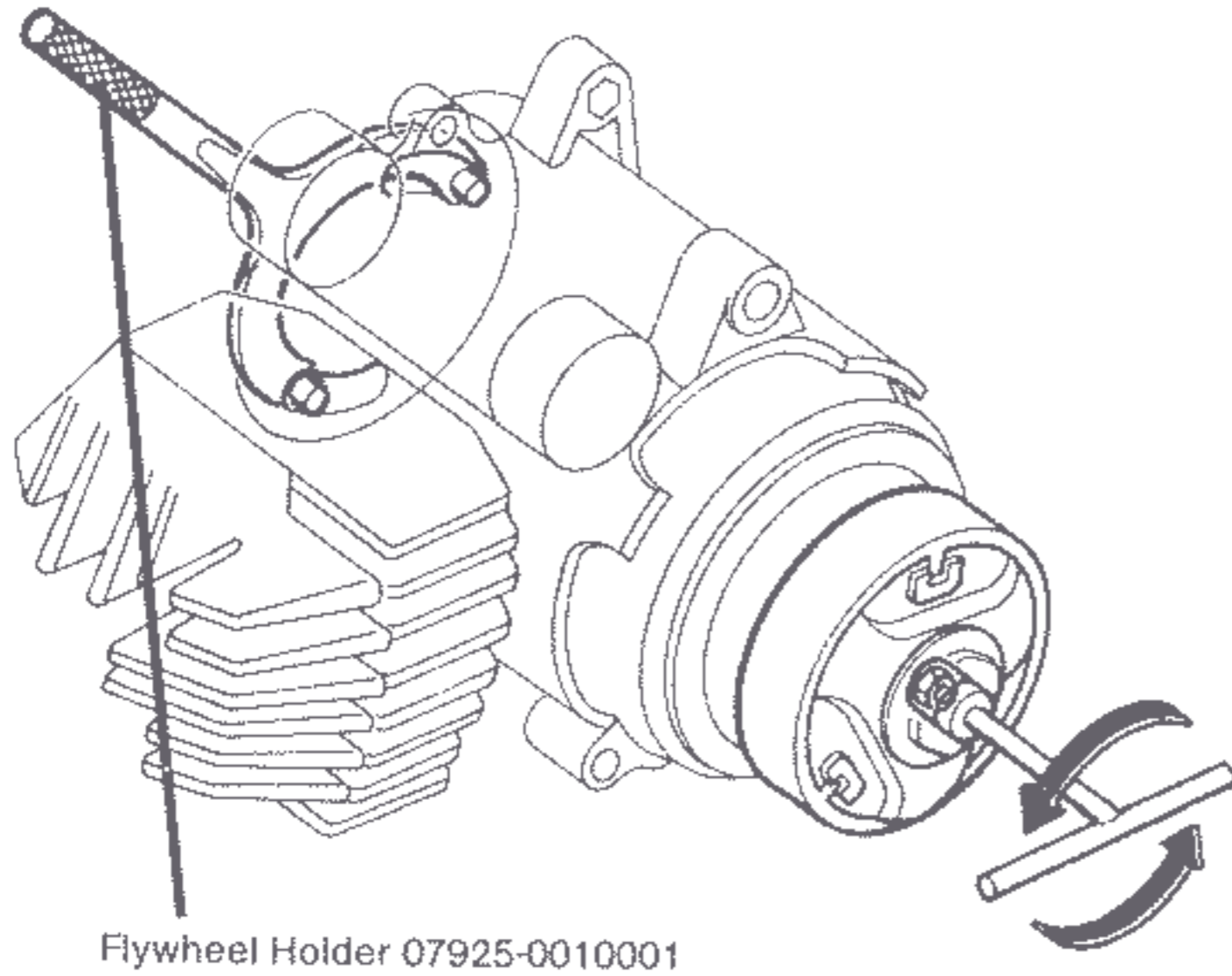

● Drive face securing nut

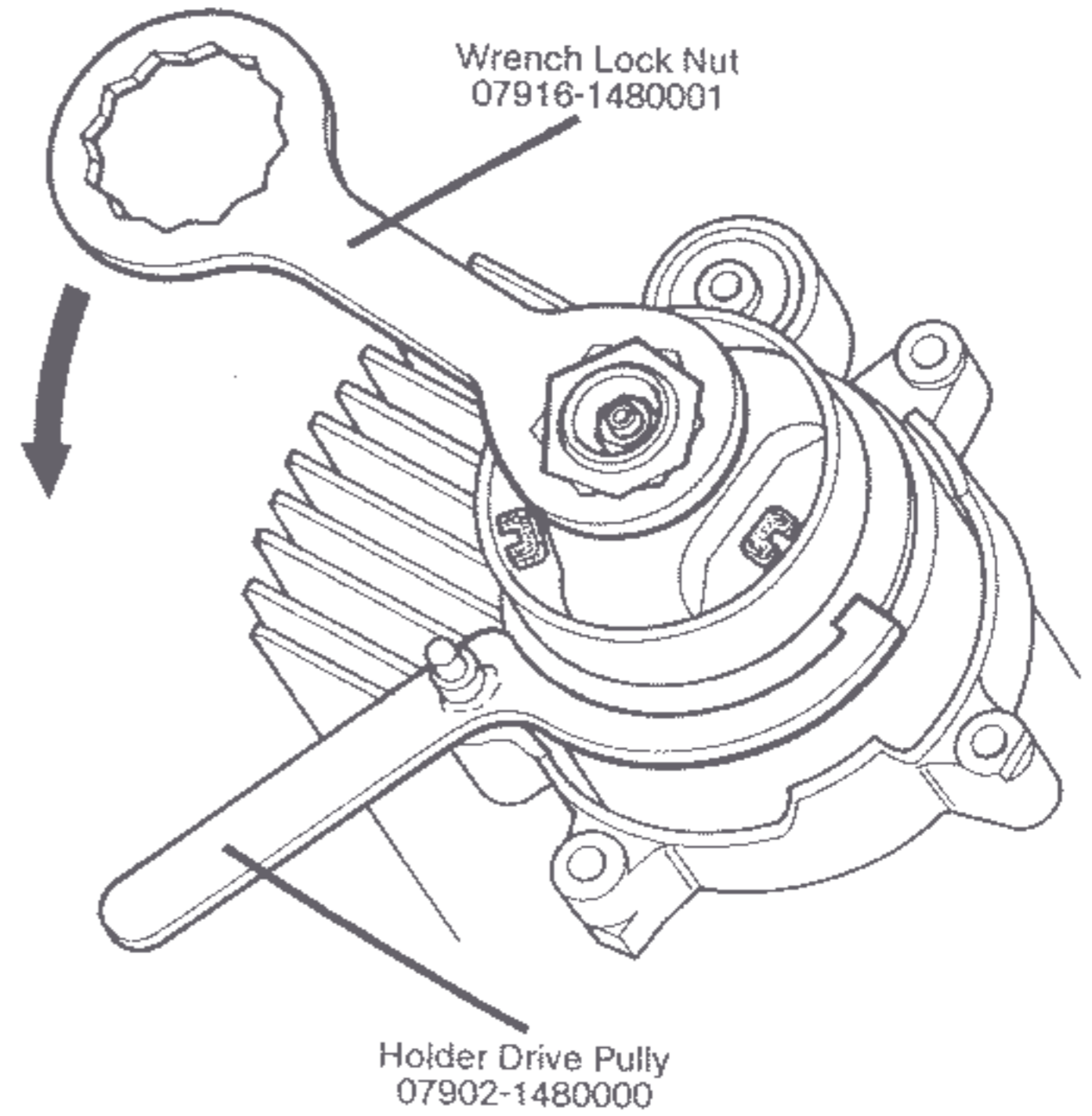

● Movable drive face/Ramp plate

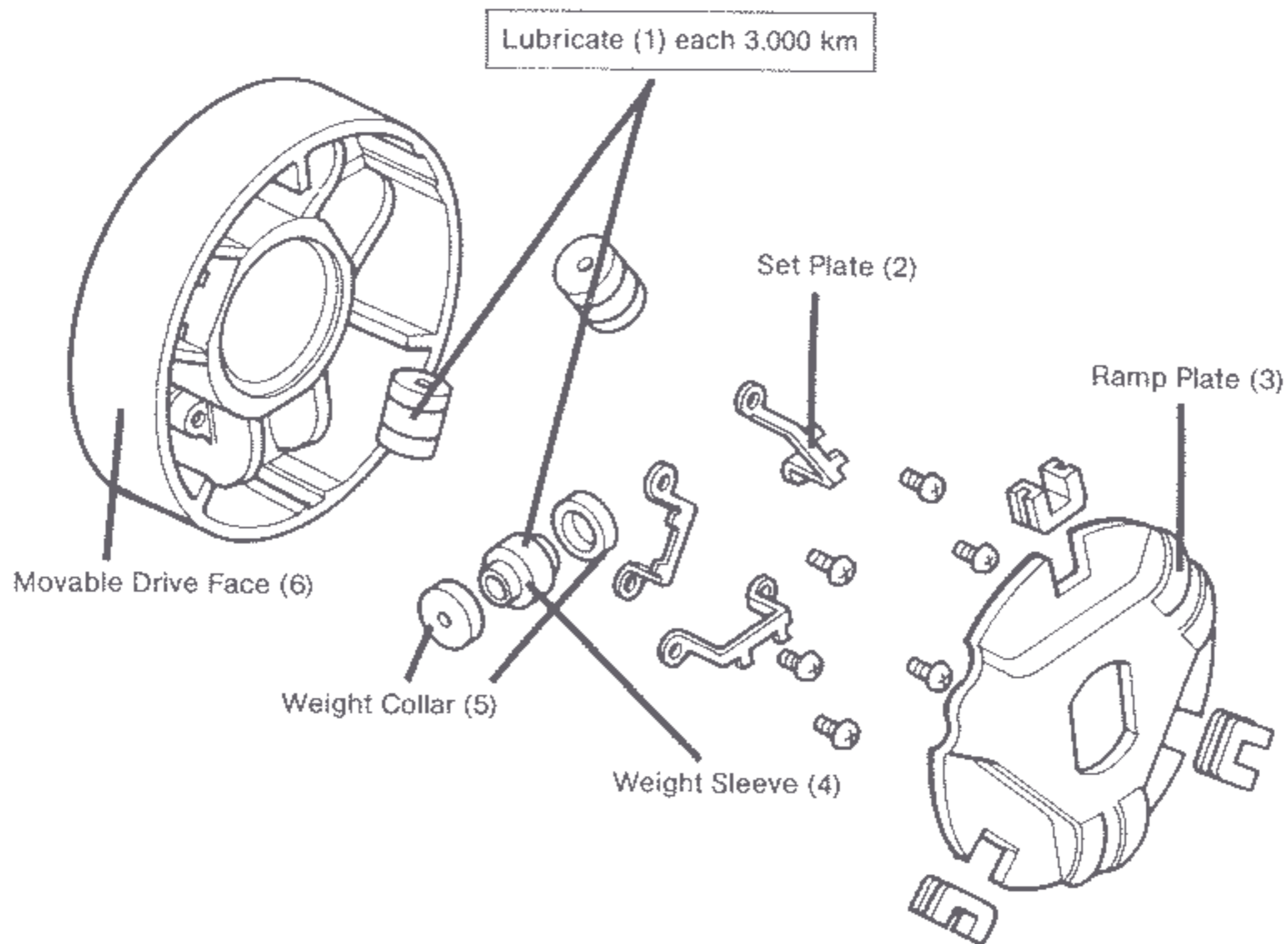

● Starting clutch disassembly

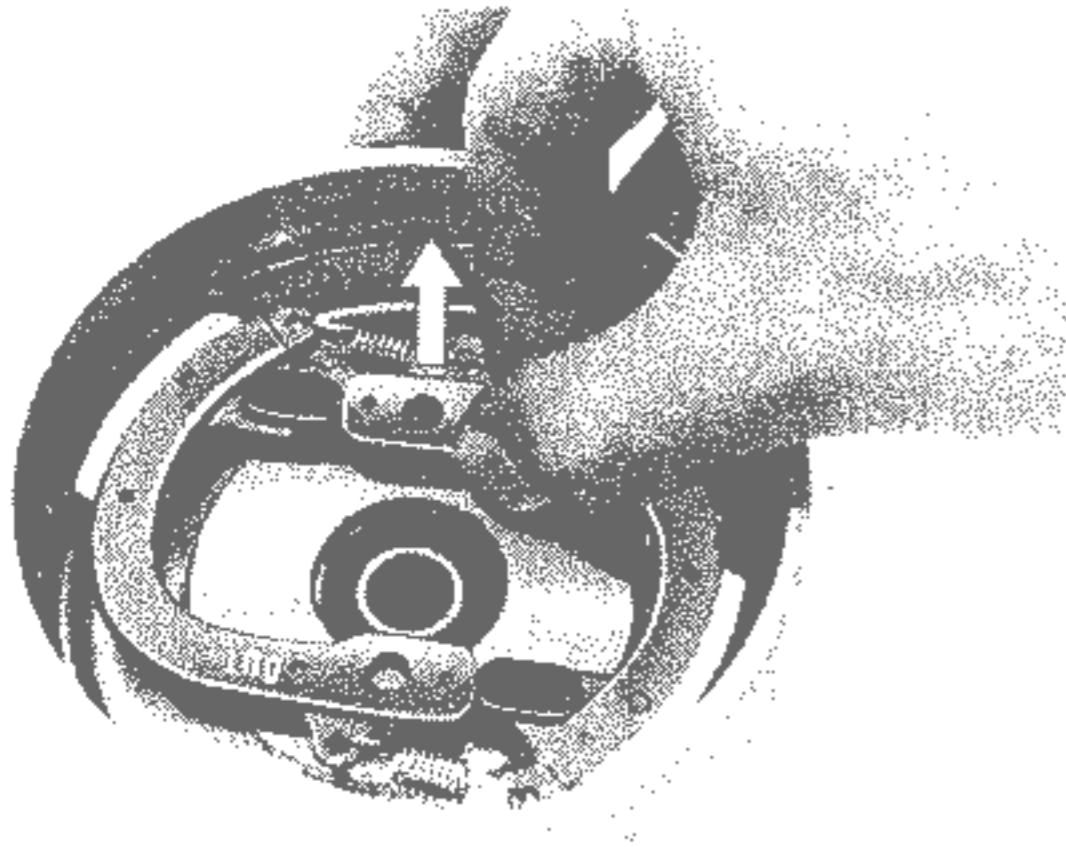

Lift up starting weight after removing the setting washers

● Starting clutch Assembly

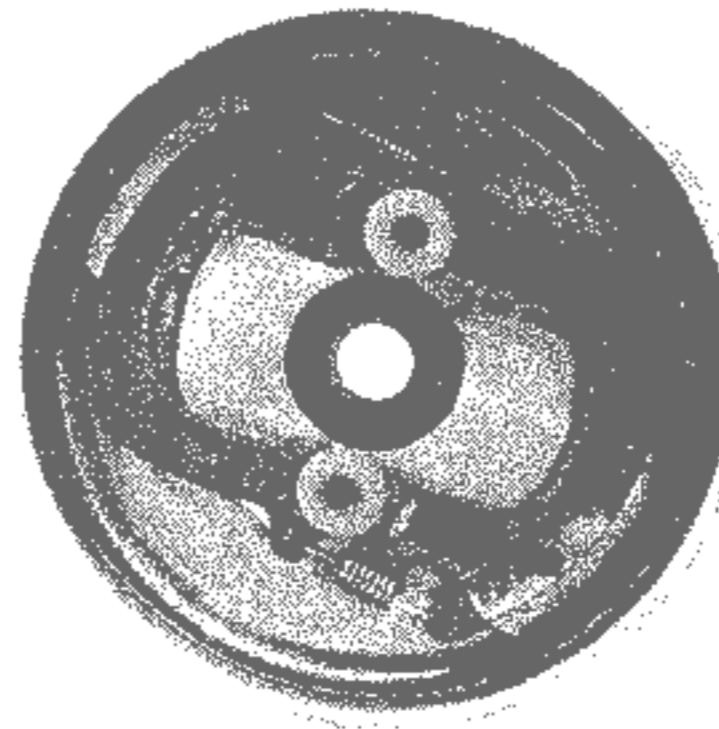

Install the starting clutch weight with "OUT" mark facing up

● Drive plate REMOVAL

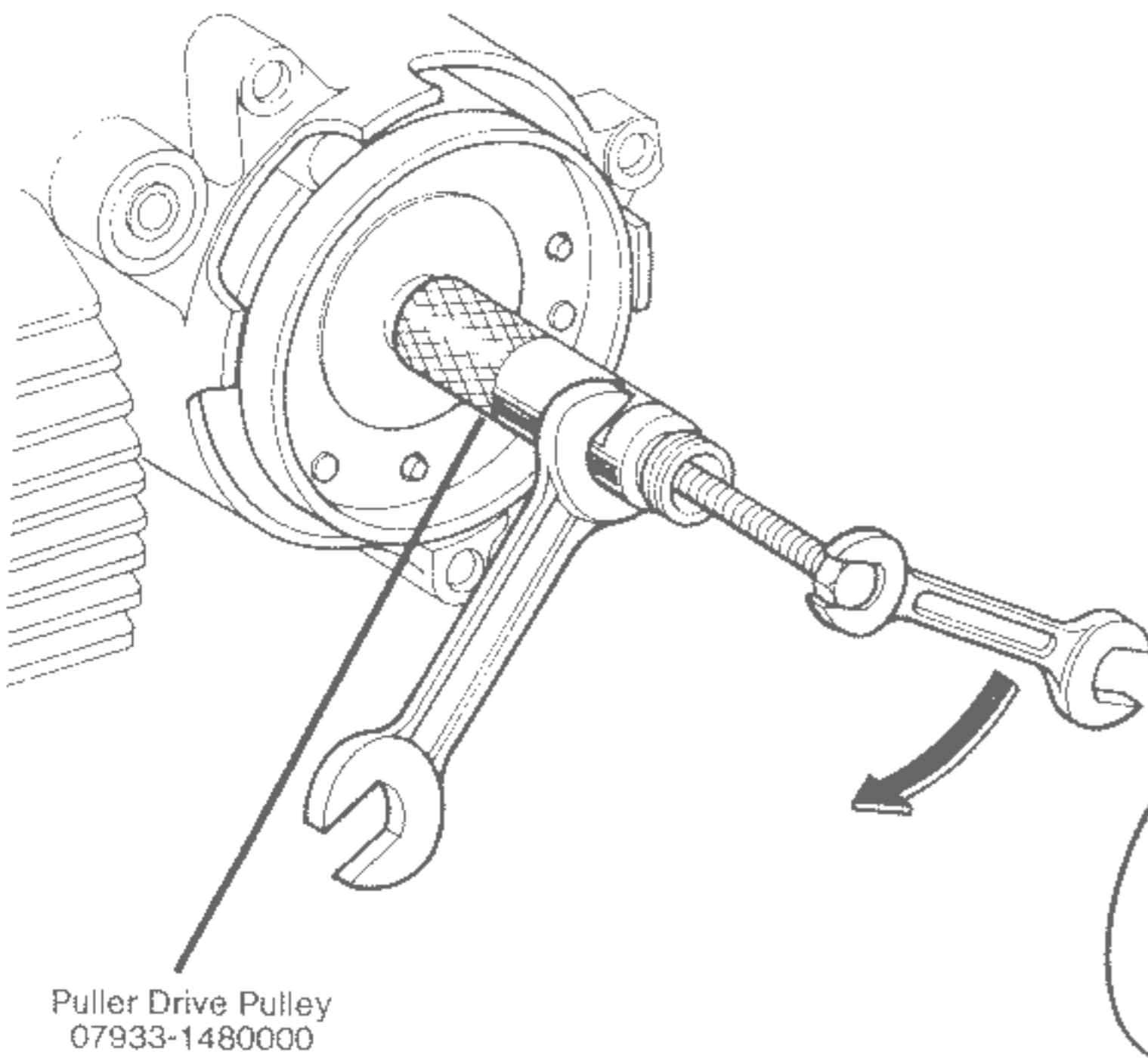

● Drive clutch DISASSEMBLY

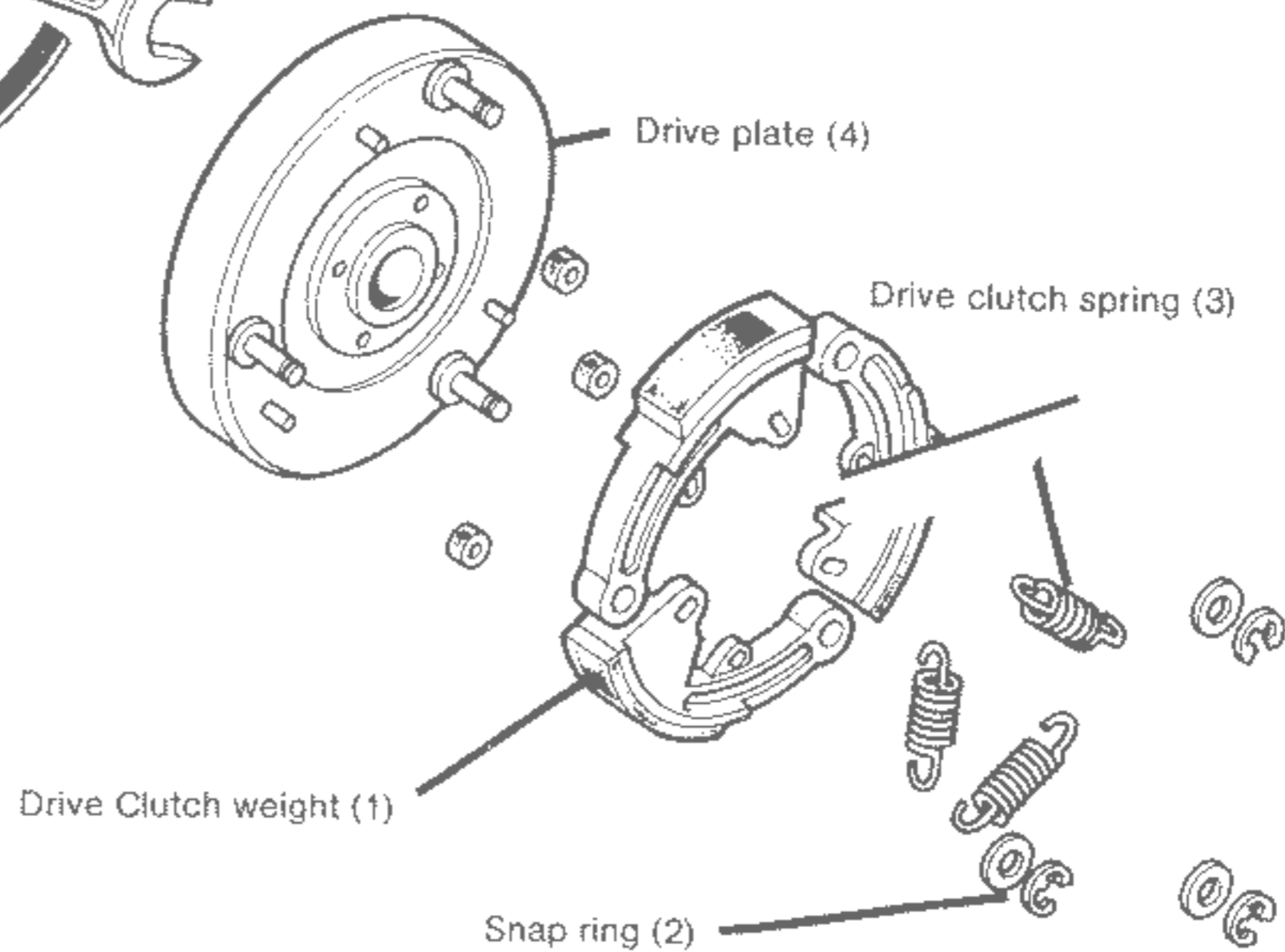

Avoid getting grease or oil on the parts



# HONDA<sup>®</sup> PA50

## Driven Pulley

- Disassemble the driven pulley

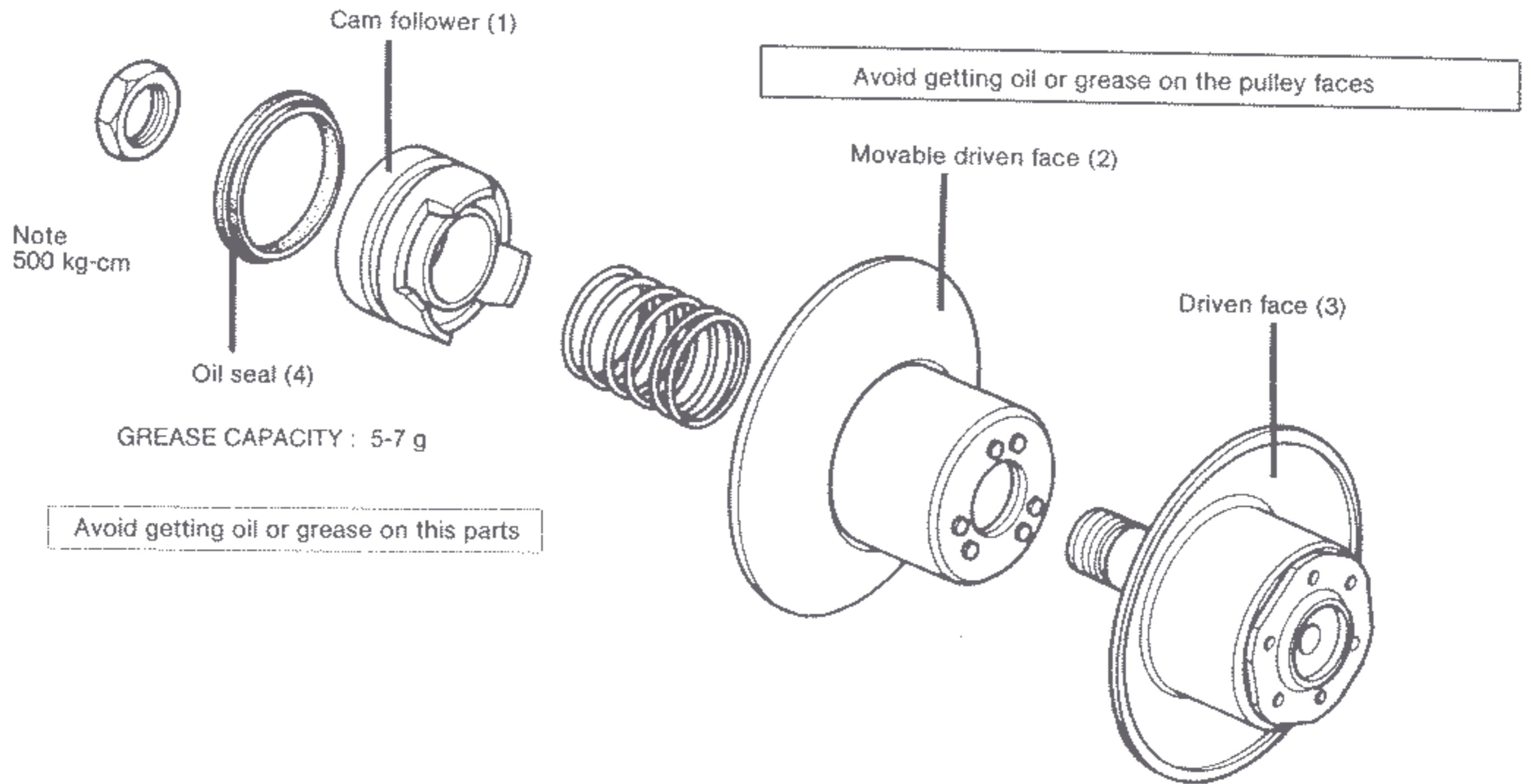

## B. Disassembly

- Remove the driven pulley attaching nut

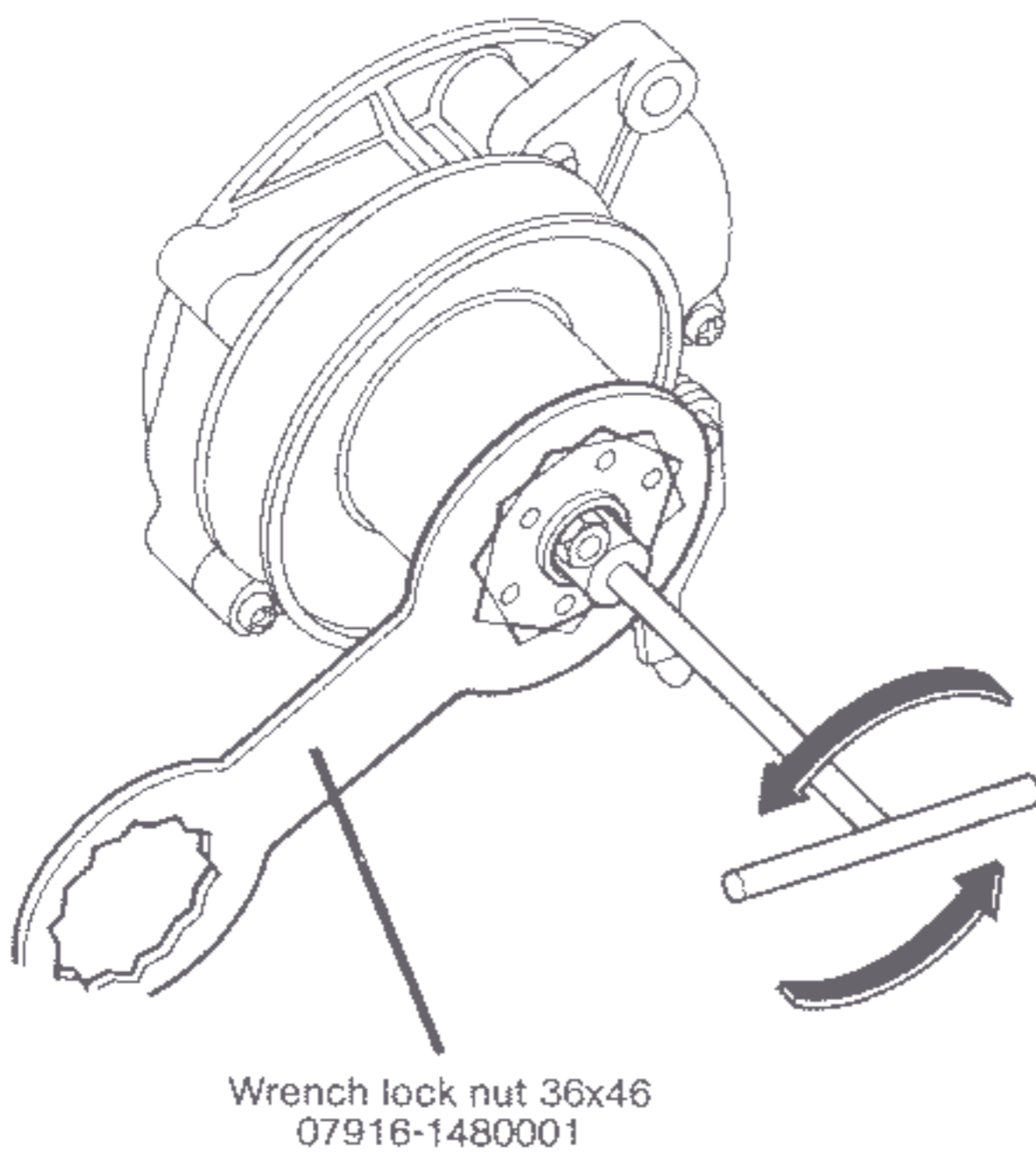

- Remove the driven pulley

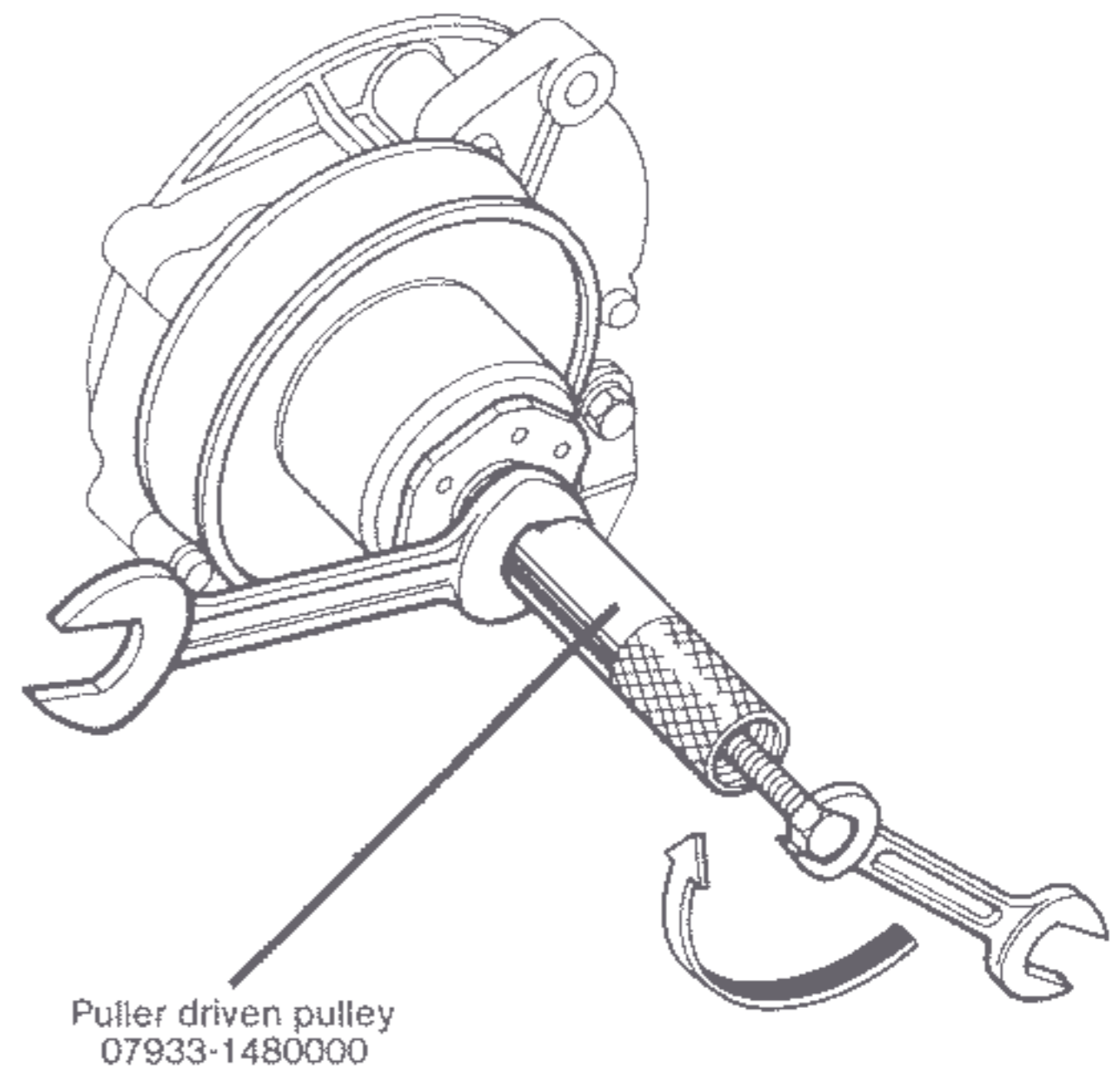

Use a 46 mm box end wrench



● Disassembly driven pulley

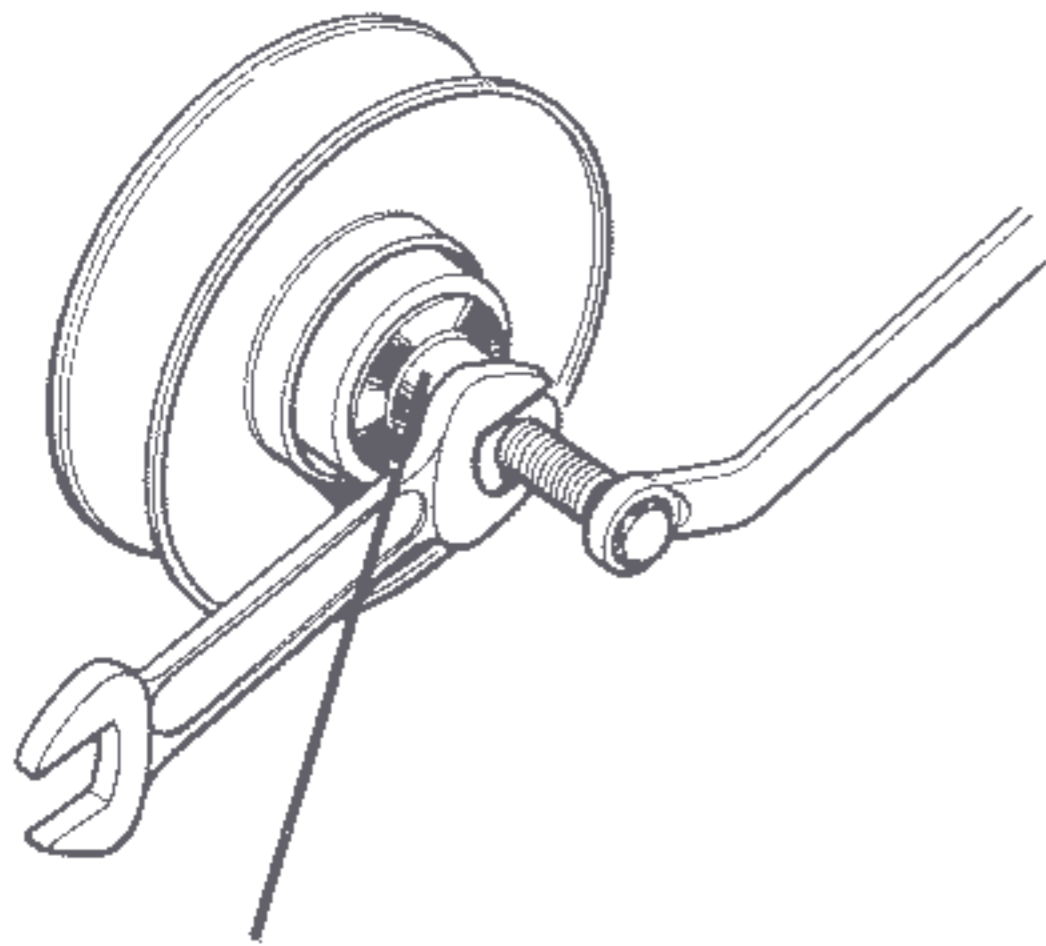

Puller pulley  
07933-1480100

● Assembly driven pulley

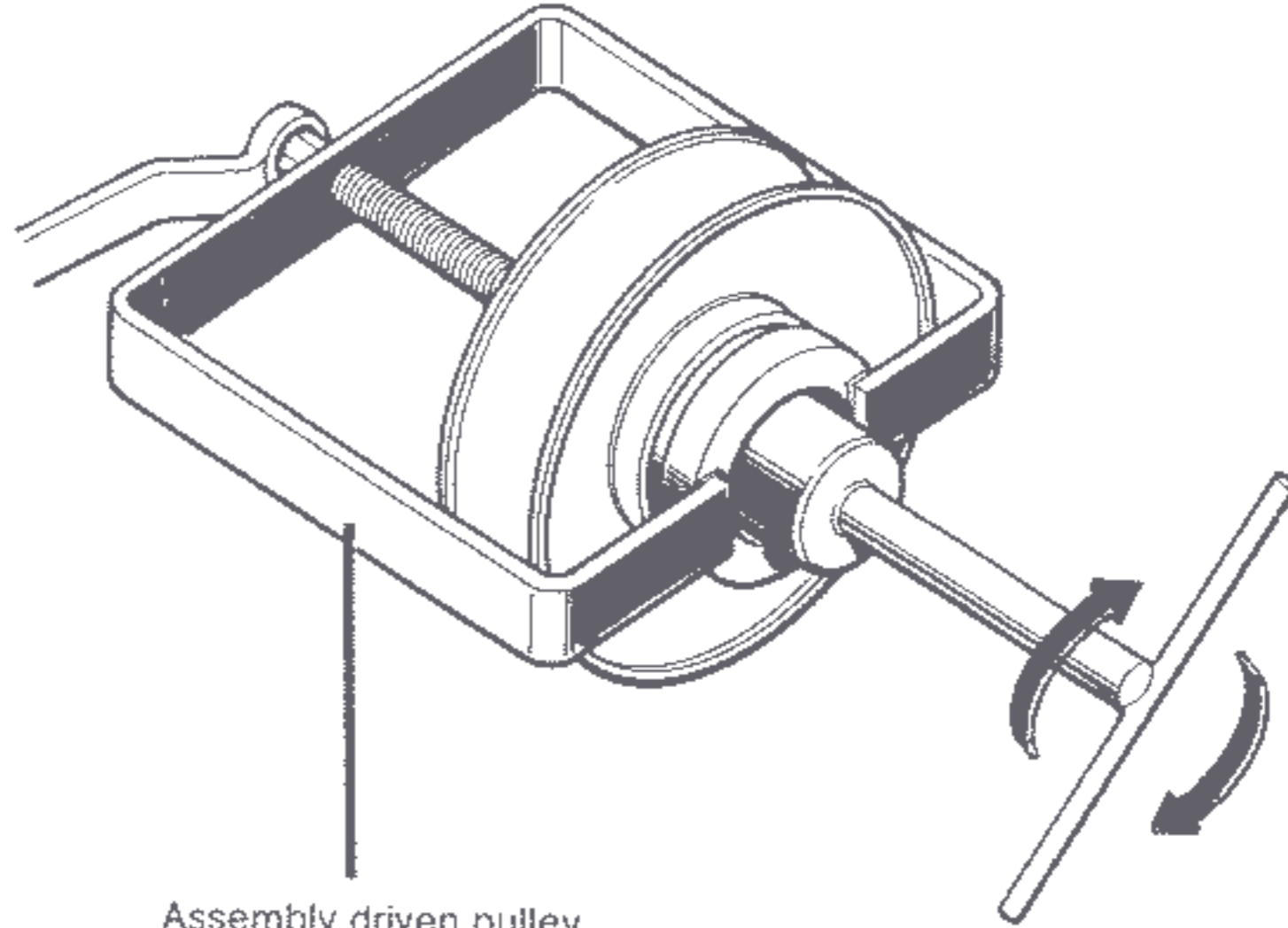

Assembly driven pulley  
07960-1480100

Tighten the special nut and caulk after.  
Setting the driven pulley with the driven pulley assembly tool.

## C. Inspection

● Free length of driven face spring

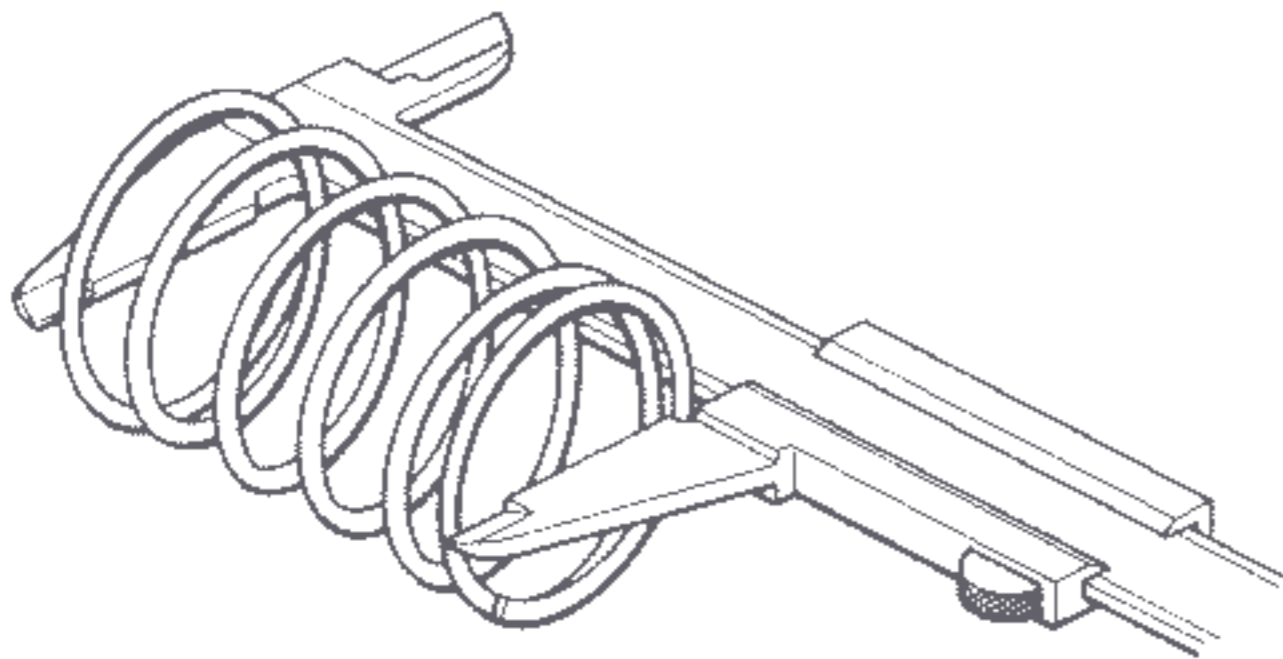

| Standard | Service Limit |
|----------|---------------|
| 72,3 mm  | 65,1 mm       |





# HONDA PA50

## Inspection

Starting clutch face (Drive Face)  
I.D.

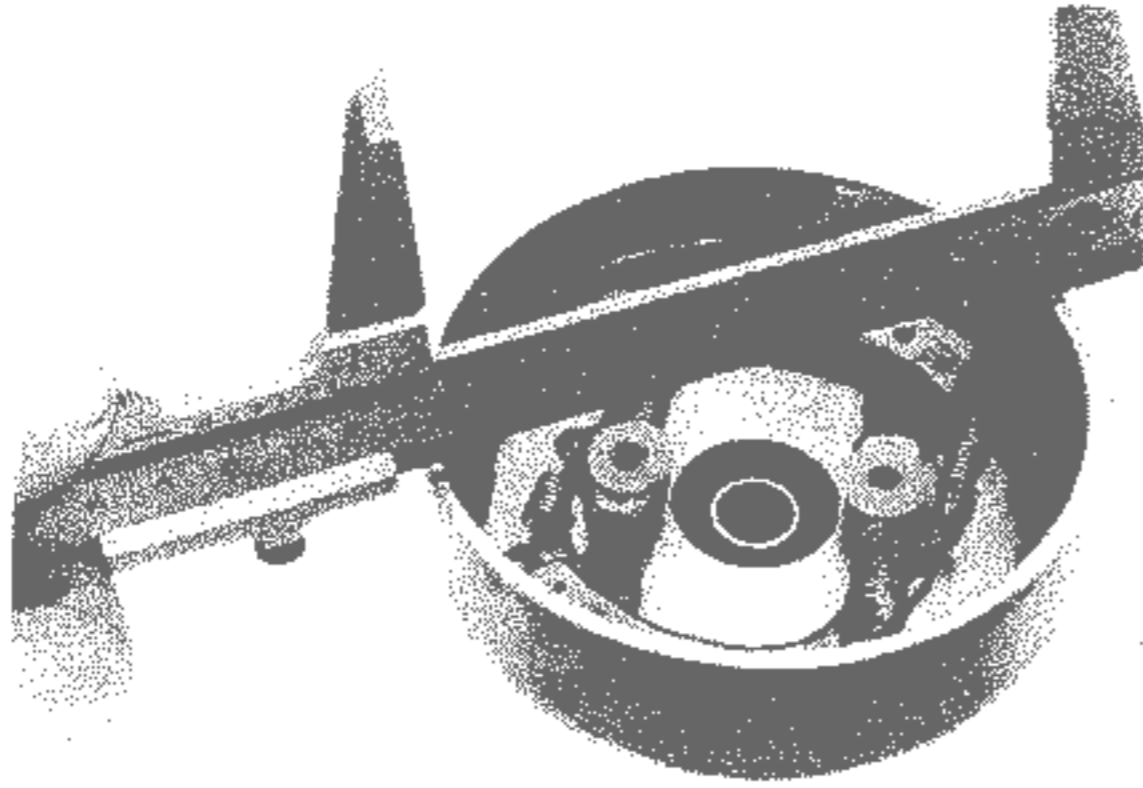

| Standard       | Service Limit |
|----------------|---------------|
| 96.9 - 97.1 mm | 97.5 mm       |

Starting clutch Thickness

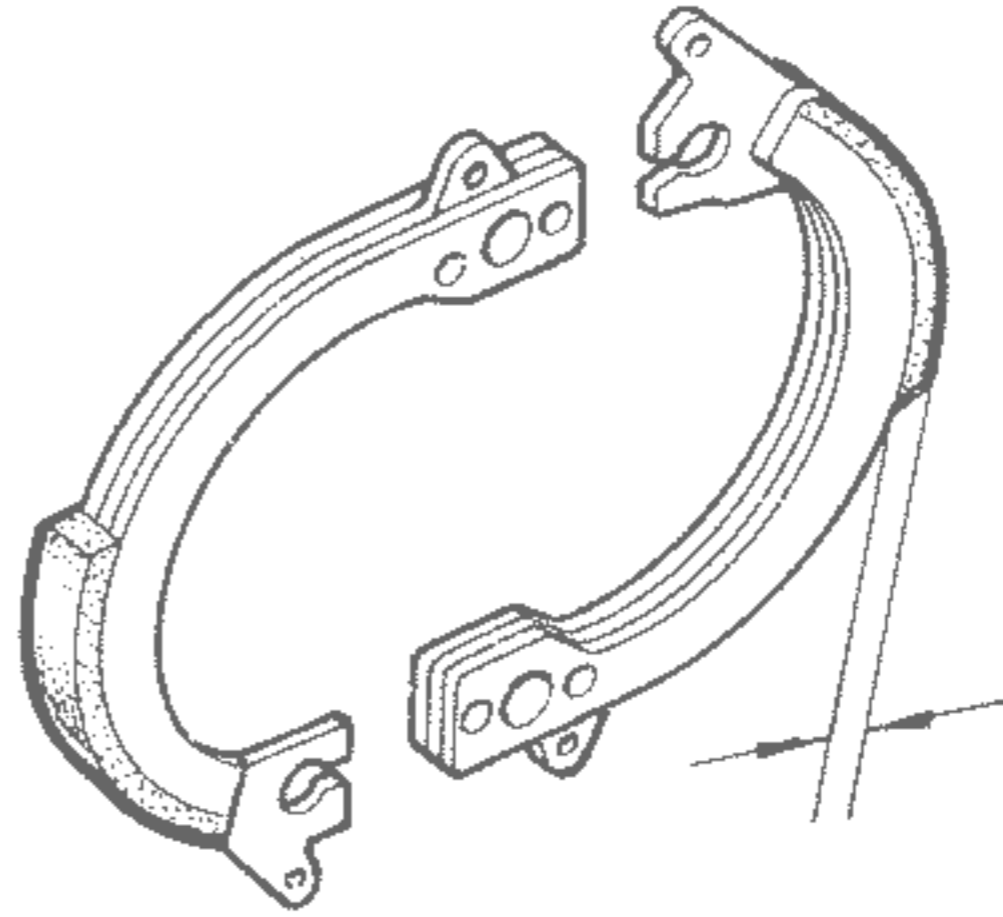

| Standard     | Service Limit |
|--------------|---------------|
| 2.9 - 3.1 mm | 1.5 mm        |

Clutch Weight Face (Drive Face)

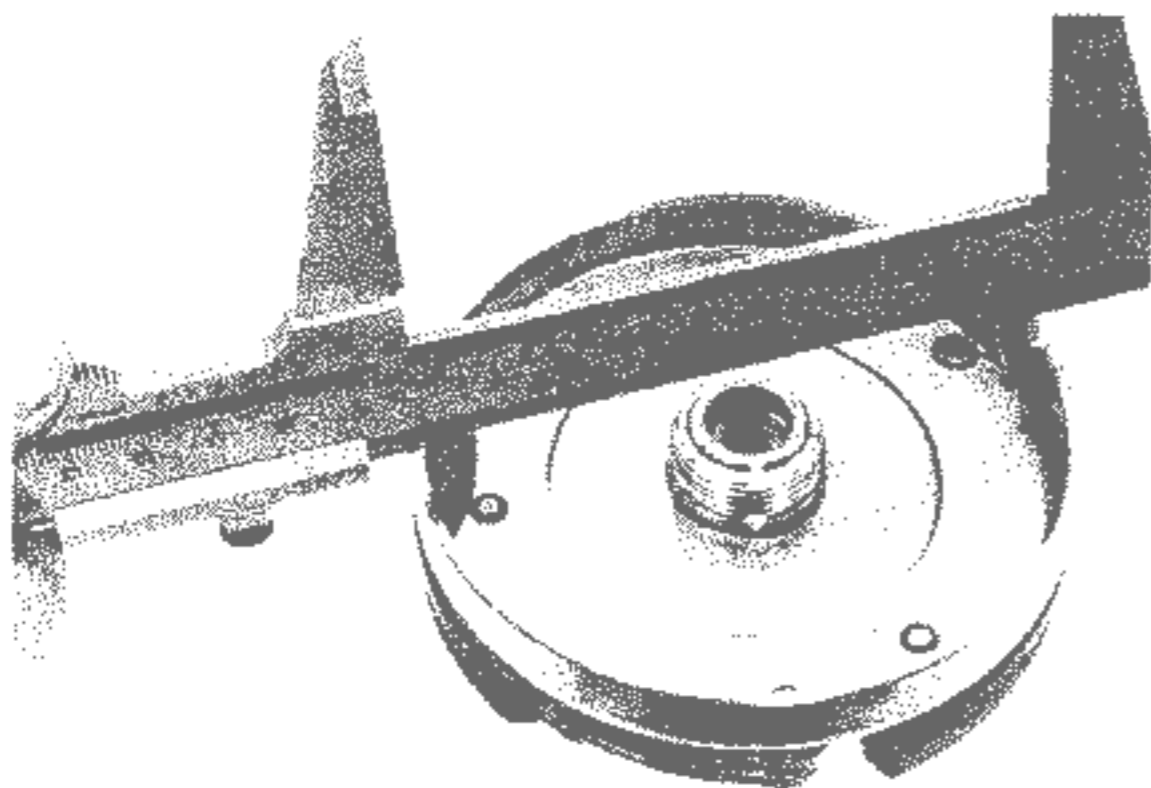

| Standard         | Service Limit |
|------------------|---------------|
| 104.0 - 104.1 mm | 104.5 mm      |

Clutch Weight Thickness

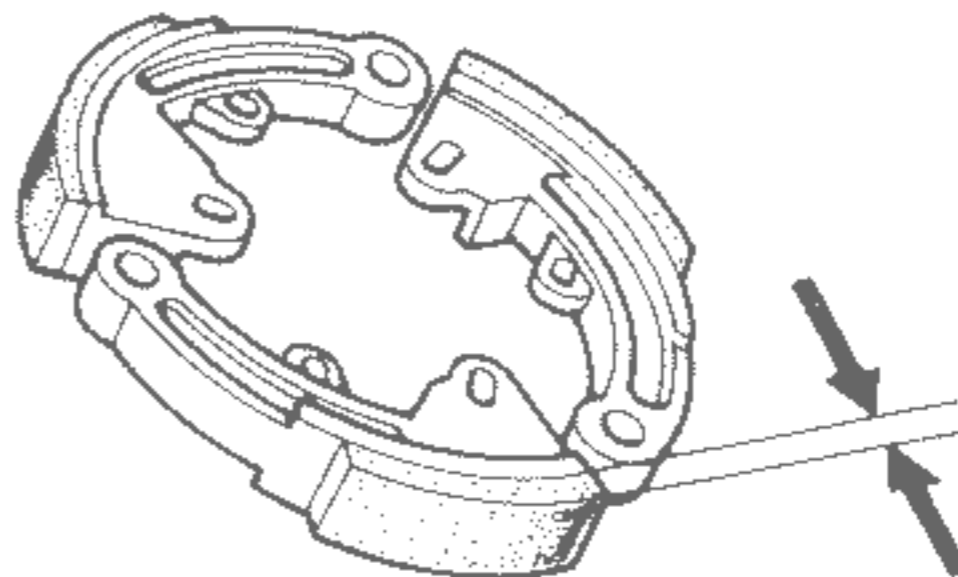

| Standard     | Service Limit |
|--------------|---------------|
| 3.4 - 3.6 mm | 2.0 mm        |



# HONDA PA50

Drive pulley base O.D.

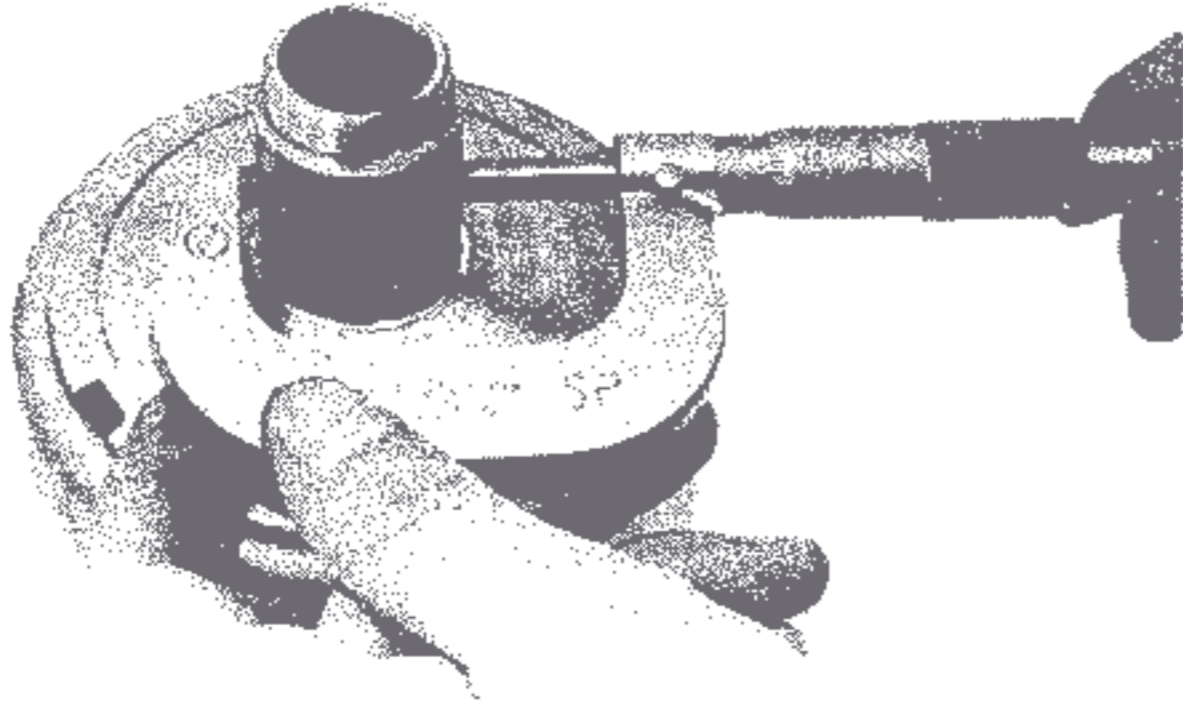

| Standard           | Service Limit |
|--------------------|---------------|
| 29.979 - 30.000 mm | 29.9 mm       |

Movable drive pulley bushing I.D.



| Standard        | Service Limit |
|-----------------|---------------|
| 30.005 - 30,011 | 30.1 mm       |



# HONDA<sup>®</sup> PA50

## 9. CRANKSHAFT/CRANKCASE

|                               |    |
|-------------------------------|----|
| A. Trouble Shooting .....     | 63 |
| B. Disassembly/Assembly ..... | 64 |
| C. Inspection .....           | 66 |

### A. Trouble Shooting

| Symptom                        | Probable cause  |
|--------------------------------|---|
| No or loss of compression      | Compression leak past oil seal<br>Compression leak past crankcase mating faces<br>Defective reed valve<br>Defective decompression valve |
| Poor performance at high speed | Compression leak past oil seal<br>Compression leak past crankcase mating faces<br>Defective reed valve                                  |
| Engine stalls                  | Compression leak past oil seal<br>Compression leak past crankcase mating faces<br>Defective reed valve                                  |



# HONDA PA50

## B. Disassembly/Assembly

- ① Remove the engine
- ② Remove the cylinder head and piston
- ③ Remove the drive pulley
- ④ Remove the A.C. generator

**NOTE:**  
Do not score or scratch parts  
The crankcase must be tighten correctly

**NOTE:**  
Replace with a new gasket during reassembly

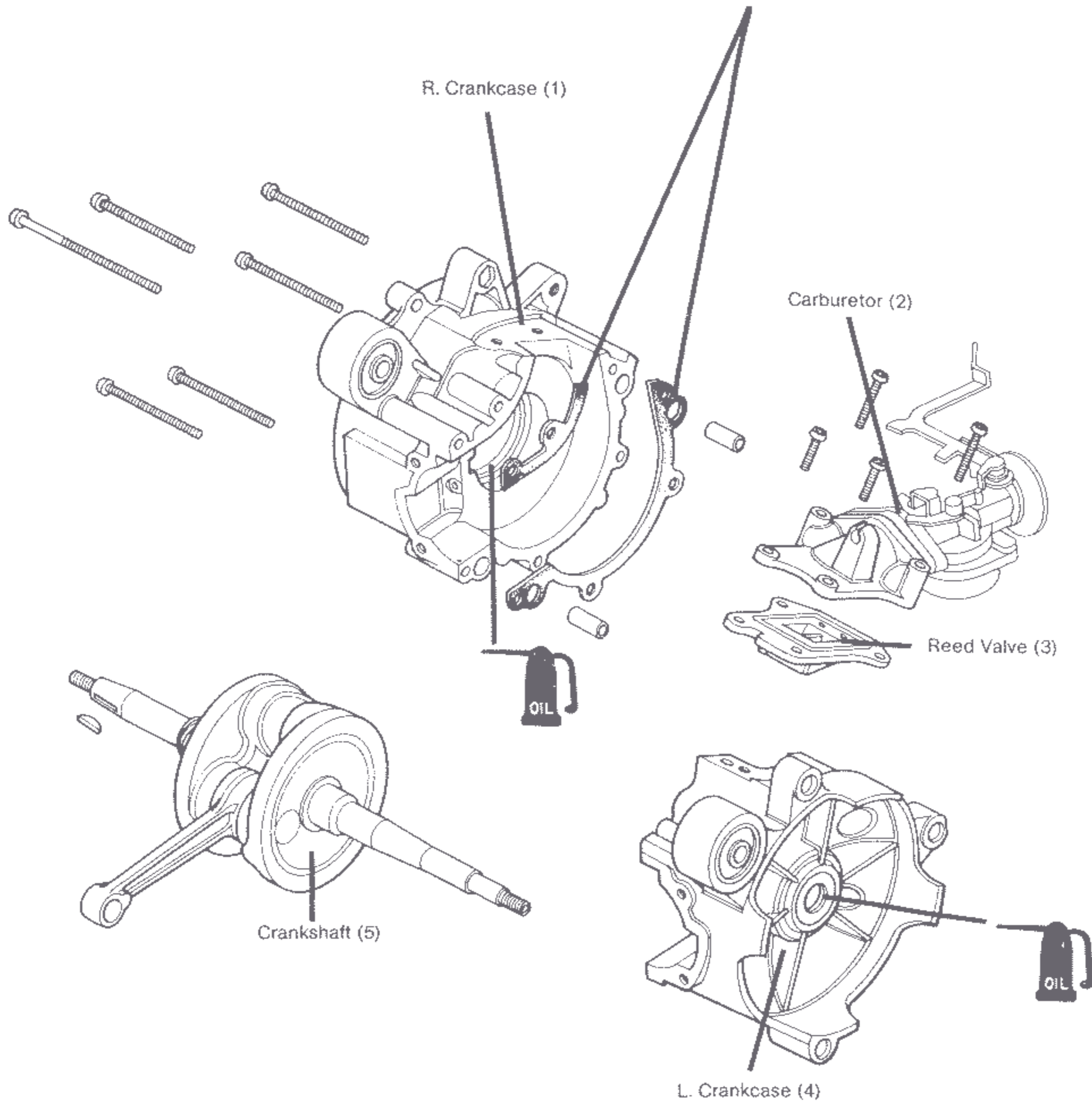

**NOTE:**  
Replace the ball bearing oil seal  
when disassembling



## Crankshaft/Crankcase DISASSEMBLY

Unscrew the crankcase setting screws

● L. Crankcase

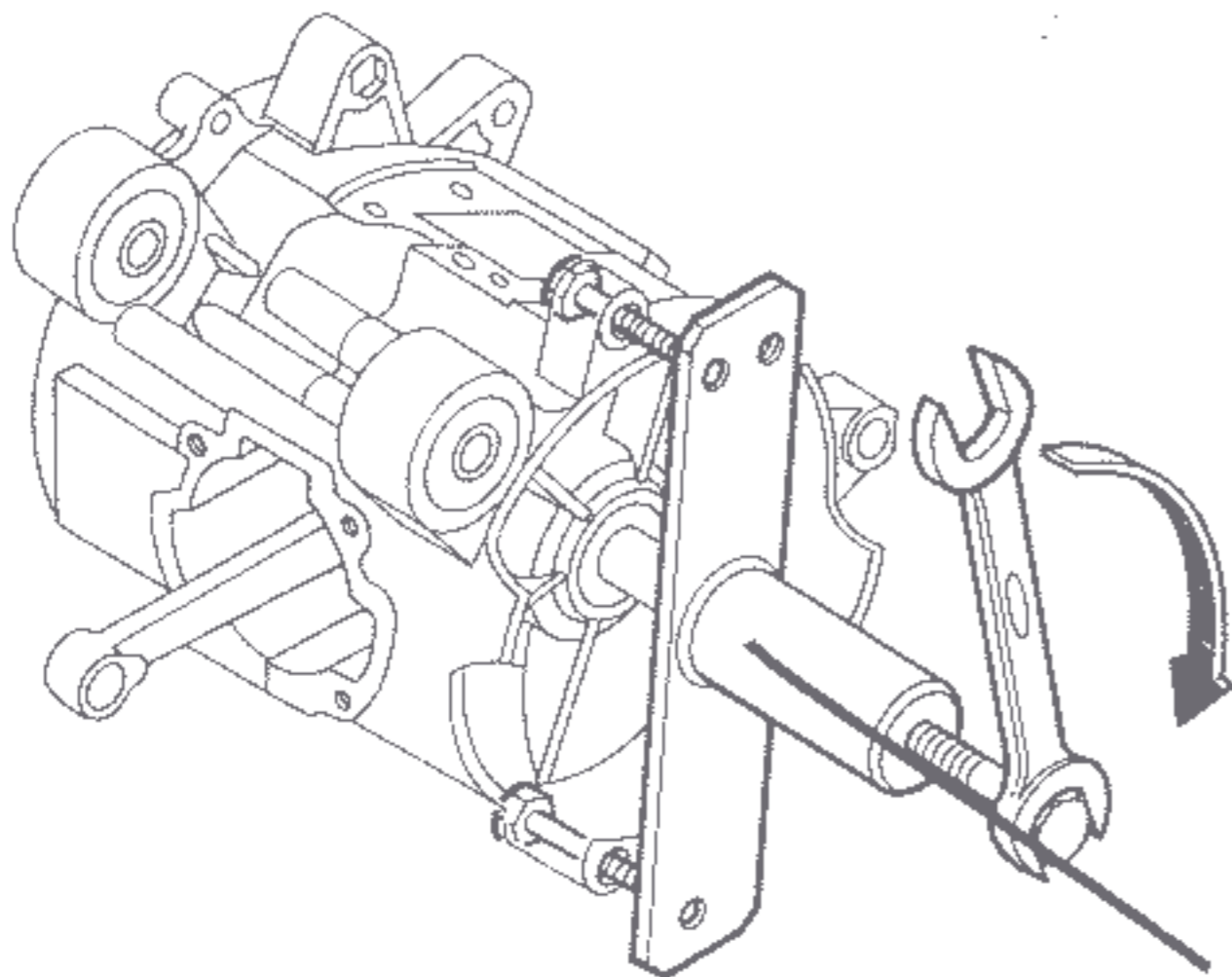

● R. Crankcase

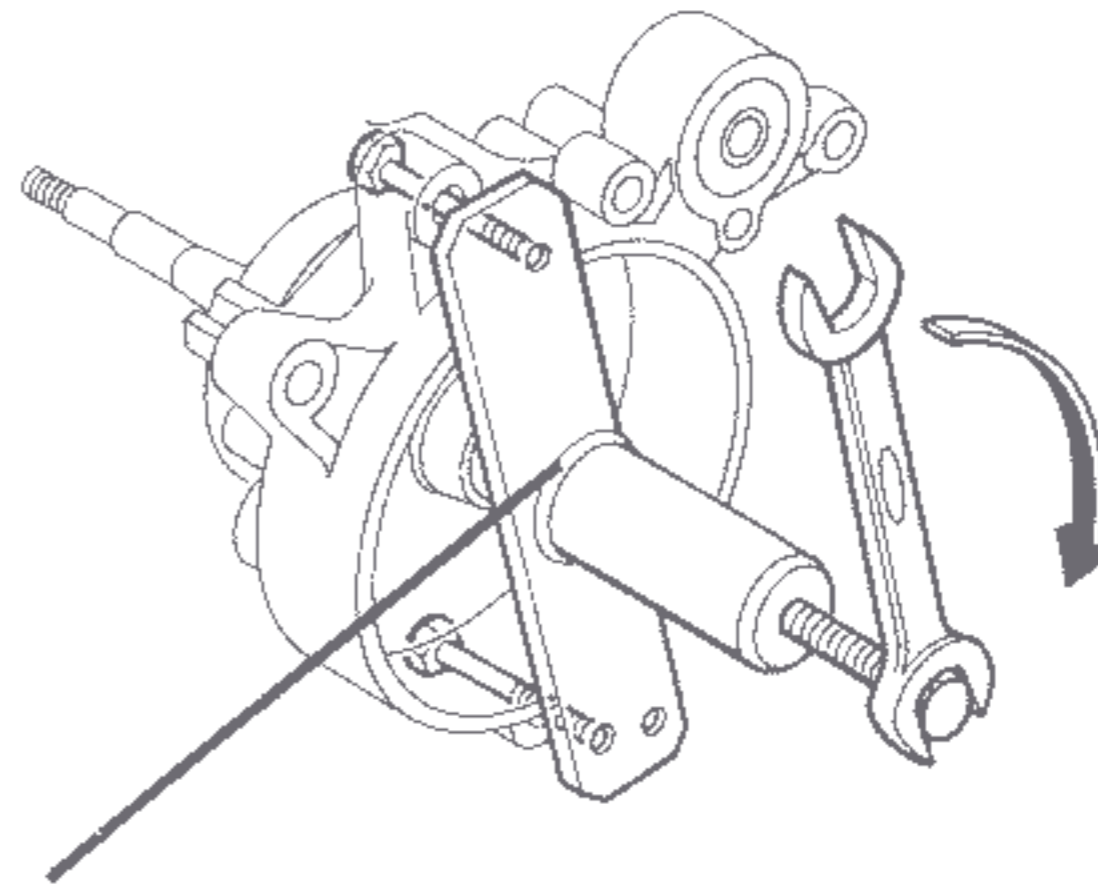

Puller case  
07935-1480000

### NOTE:

Tighten bolts securely when installing puller  
Hold the crankshaft so that it cannot be removed by hand

## Crankshaft/Crankcase Assembly

● R. Crankcase

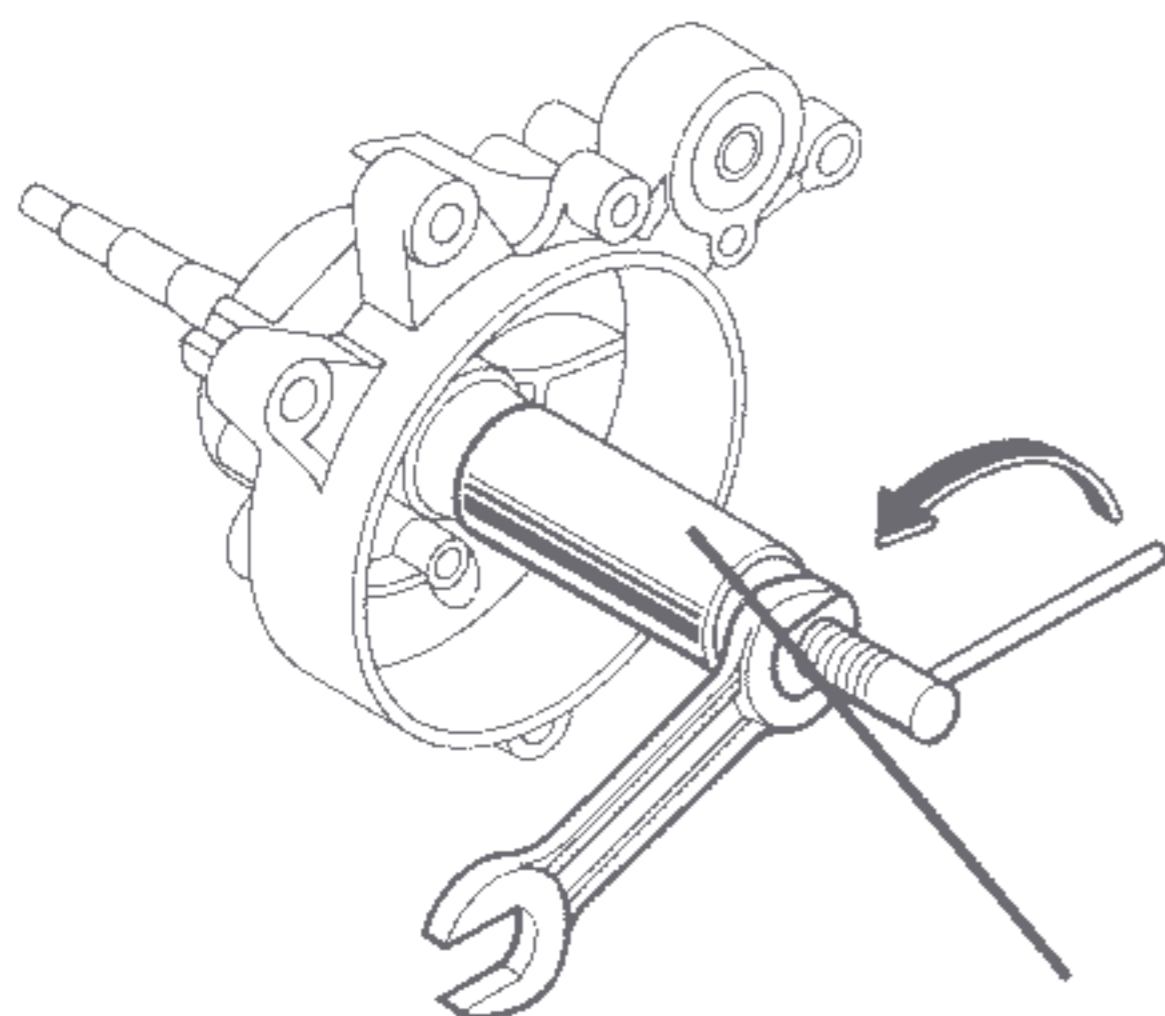

● L. Crankcase

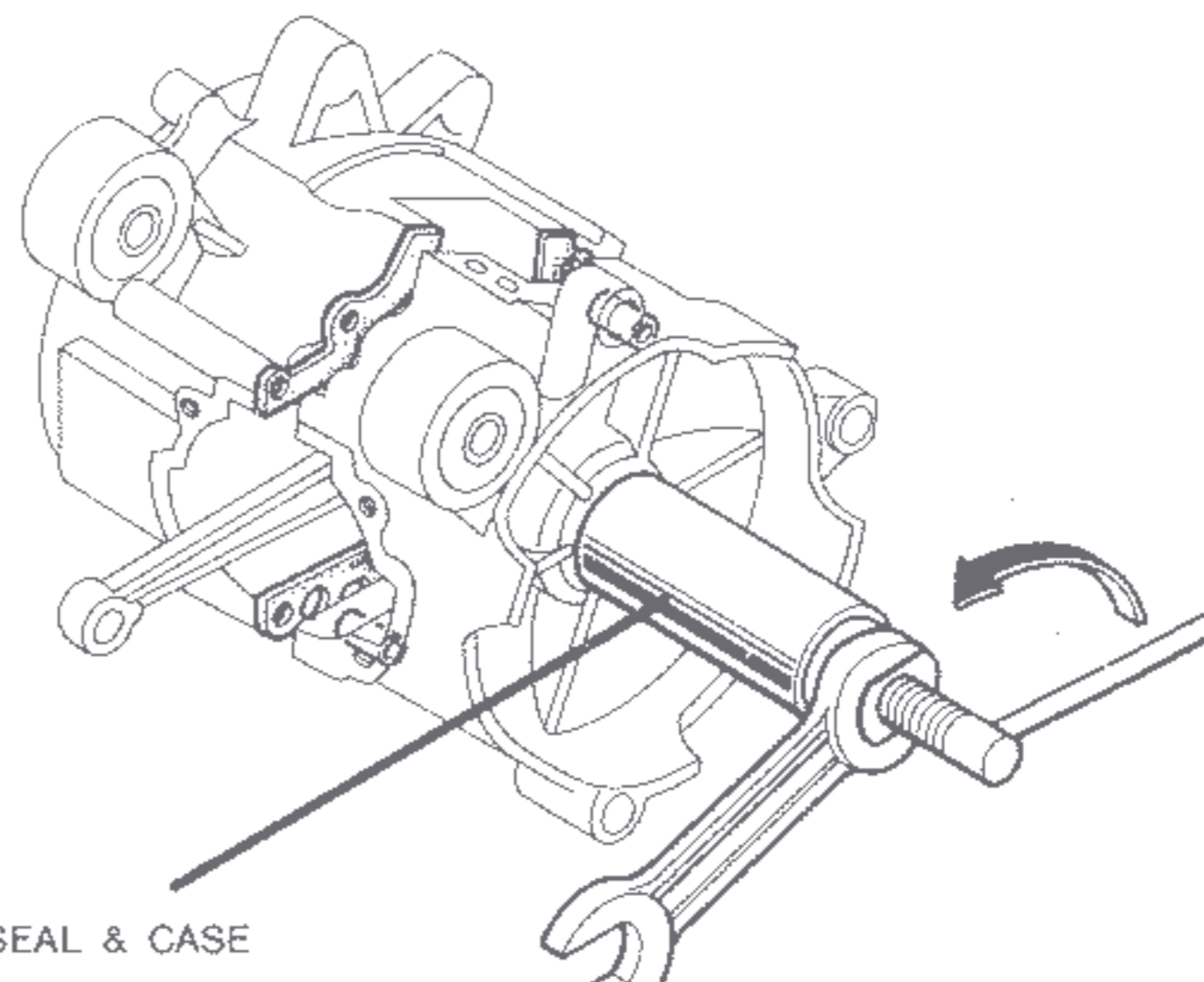

ASSEMBLY TOOL SEAL & CASE  
Nº. 07965-1480001

Slide the tool collar over the end of the crankshaft and turn in the handle of the tool bolt until the shaft fits into the bearing in the crankcase



## C. Inspection

- Check connecting rod small end bearing play

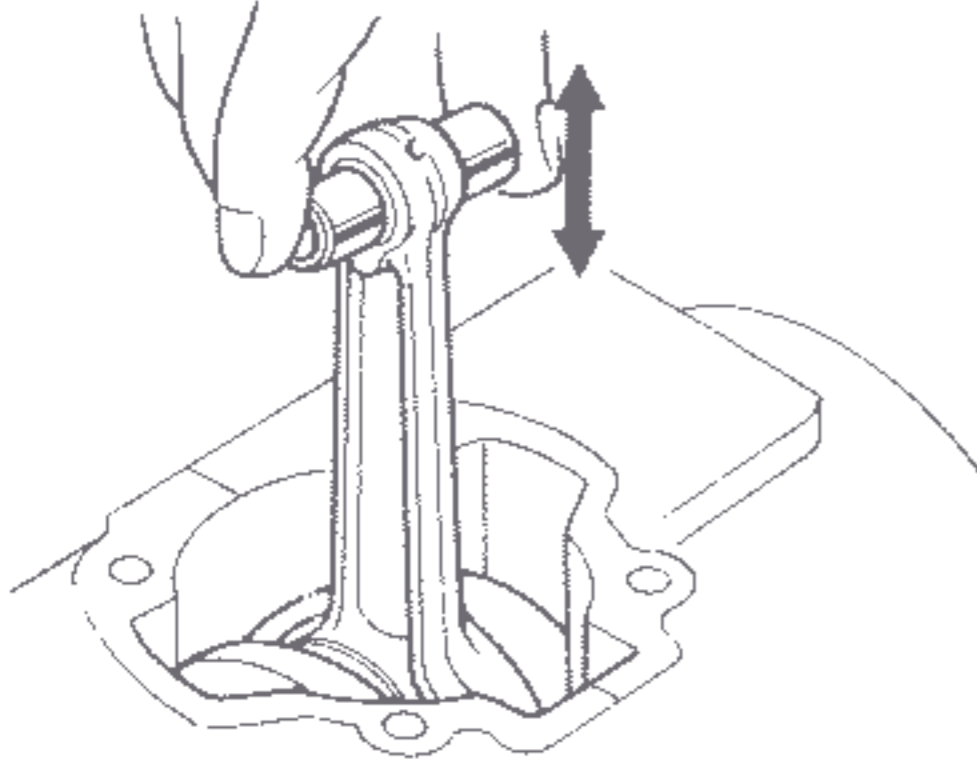

Be sure that the pin rotates smoothly without rattling

- Measure connectingrod big end bearing side clearance

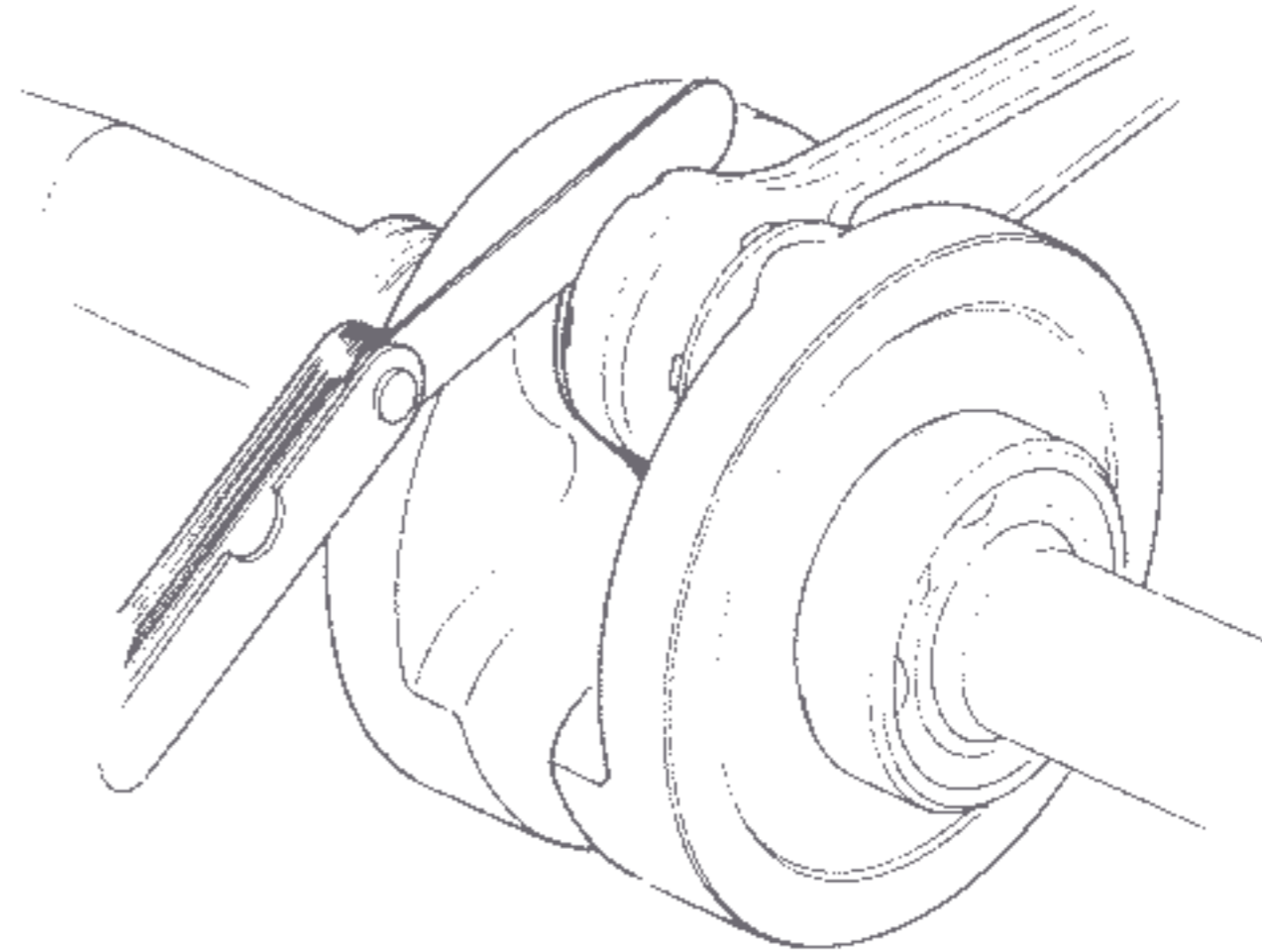

| Standard     | Service Limit |
|--------------|---------------|
| 0.15-0.41 mm | 0.6 mm        |

- Measure Crankshaft Runout

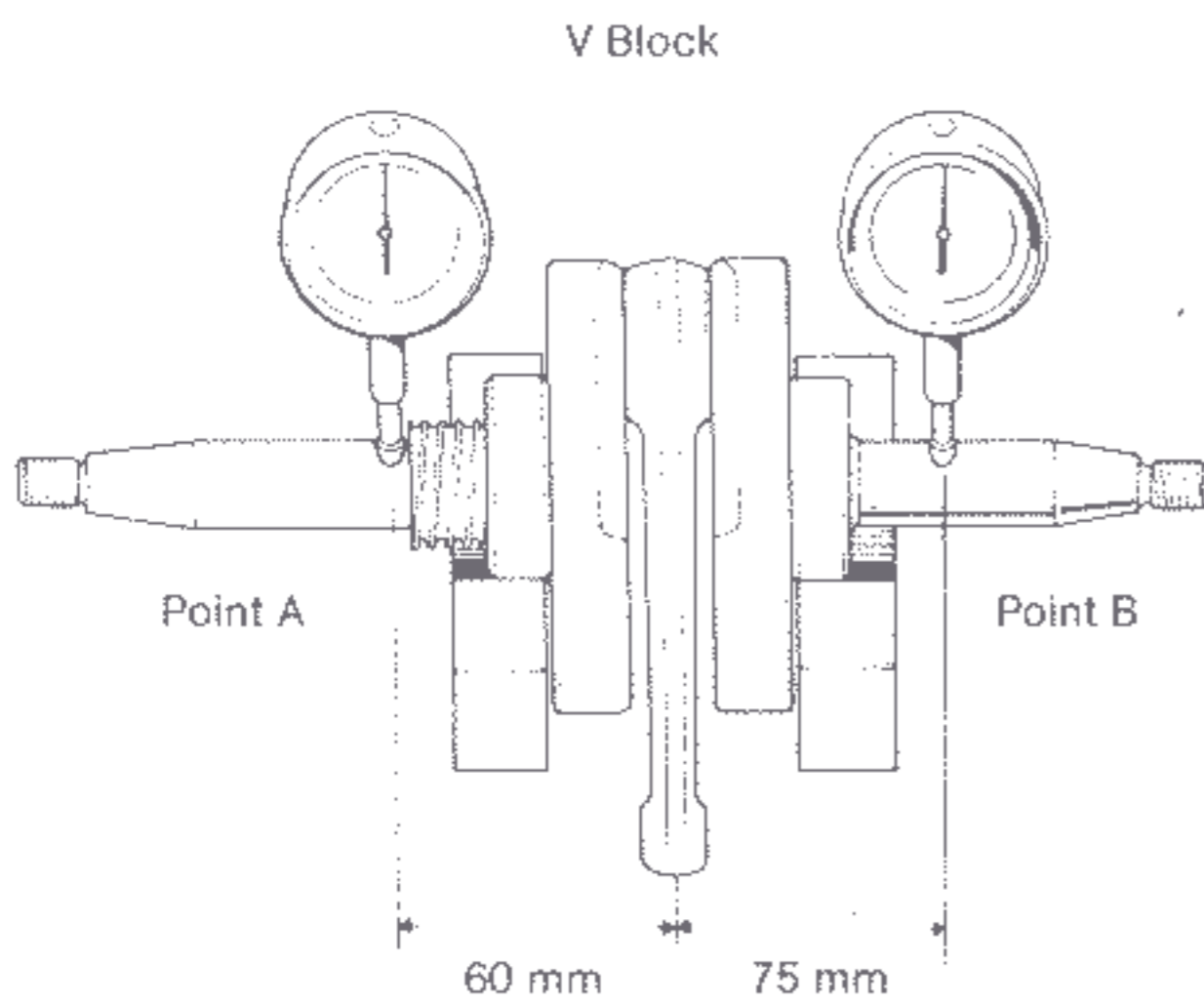

- Check bearing play

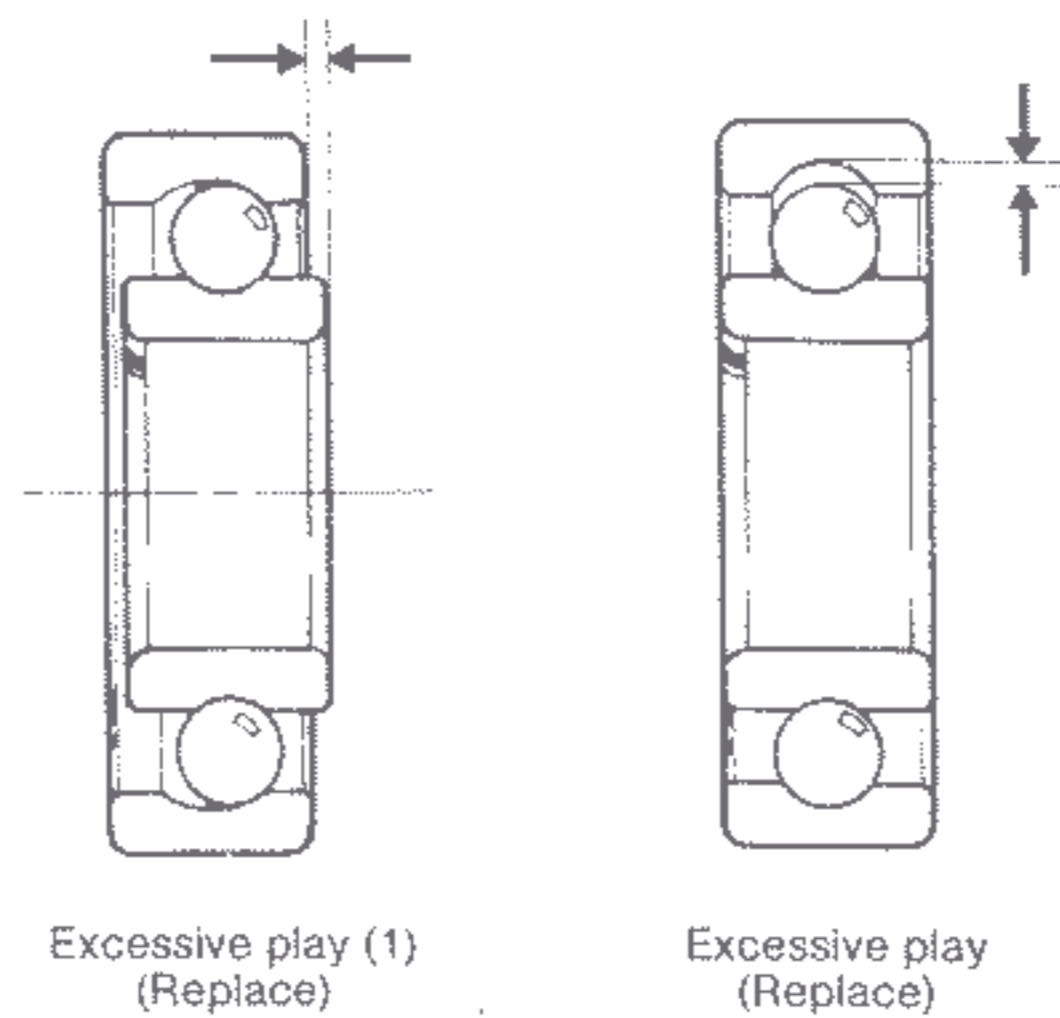

Measure at both ends A & B

| Standard | Service Limit |
|----------|---------------|
| 0.05 mm  | 0.15 mm       |



## 10. CARBURETOR/AIR CLEANER

|                               |    |
|-------------------------------|----|
| A. Trouble shooting .....     | 67 |
| B. Disassembly/Assembly ..... | 68 |
| C. Inspection .....           | 70 |
| D. Cleaning .....             | 71 |

### A. Trouble Shooting

| Symptom                        | Probable cause   |
|--------------------------------|--|
| Hard starting                  | Clogged Float Valve<br>Mixture screw out of adjustment<br>Clogged carburetor jet |
| Lack of power                  | Clogged float valve<br>Pilot screw out of alignment<br>Clogged carburetor jet    |
| Poor performance at low speed  | Clogged float valve<br>Clogged carburetor<br>Loose carburetor jet                |
| Poor performance at high speed | Clogged float valve<br>Clogged carburetor<br>Clogged Main jet                    |



## B. Carburetor Disassembly/Assembly

- Lift the frame away from the engine
- ① Unscrew four carburetor setting screws

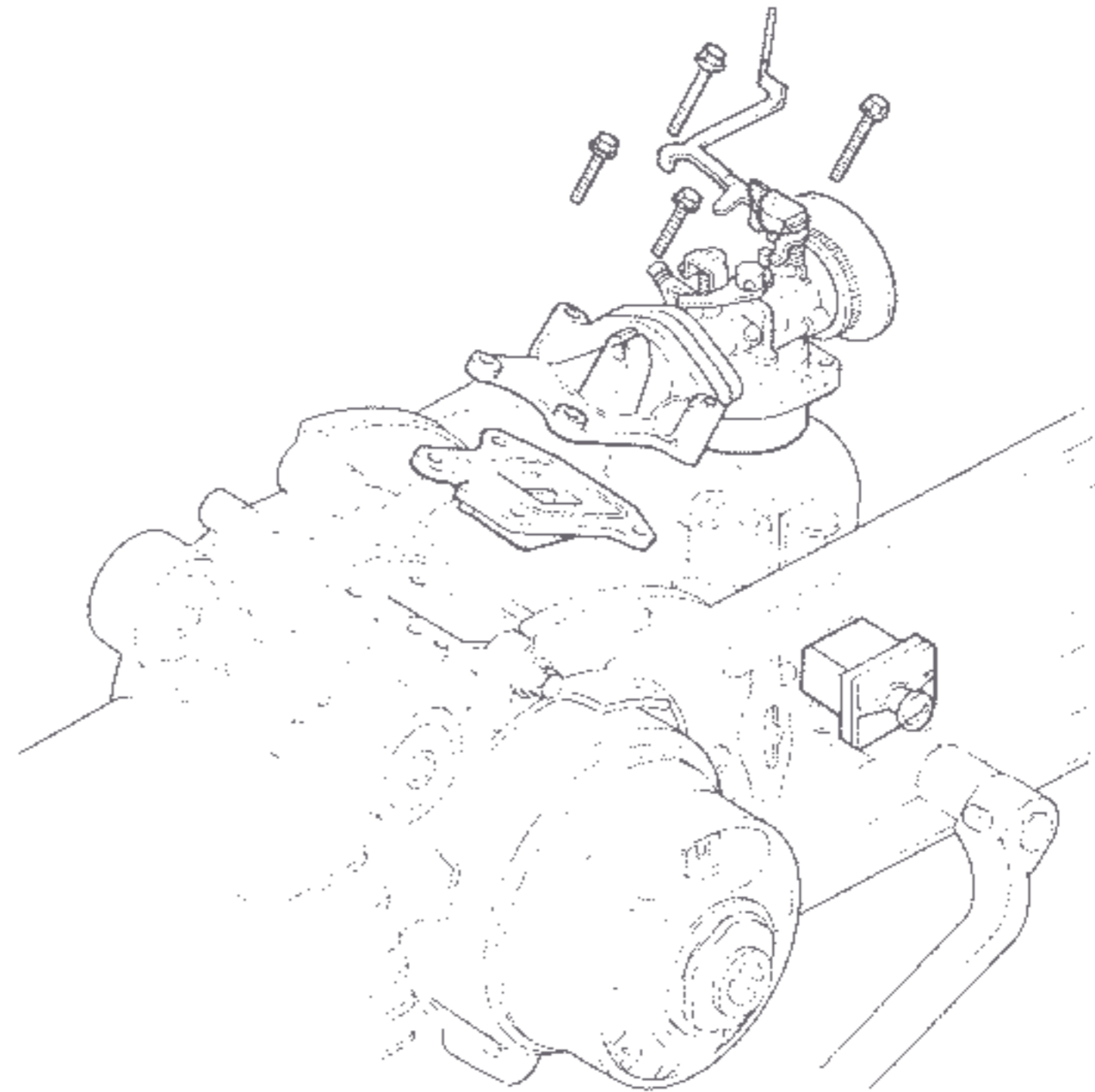

**NOTE:**

To prevent dust from entering the cylinder, do not remove the reed valve.

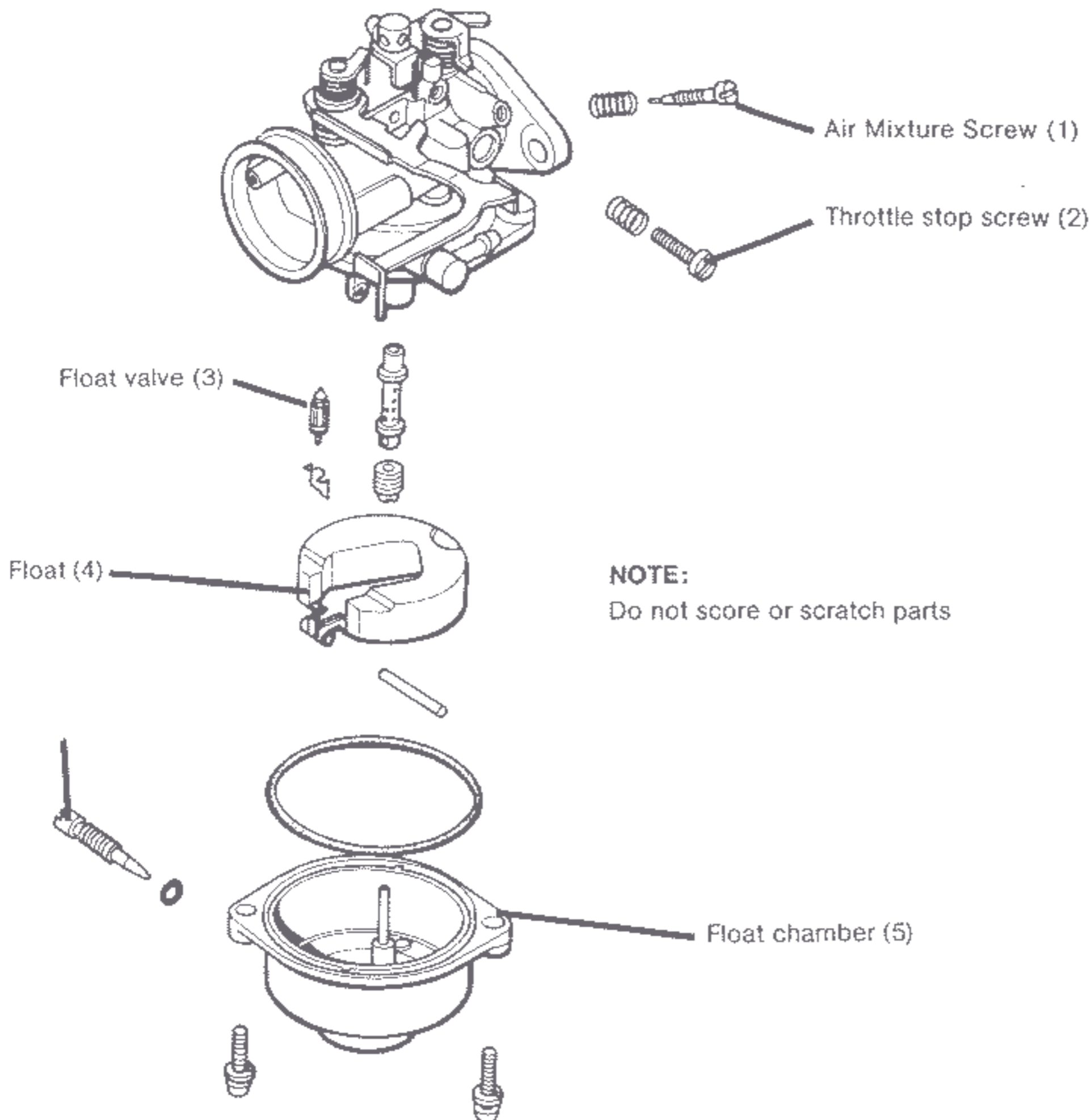





# HONDA PA50

## ● Float valve/Main Jet DISASSEMBLY/ASSEMBLY

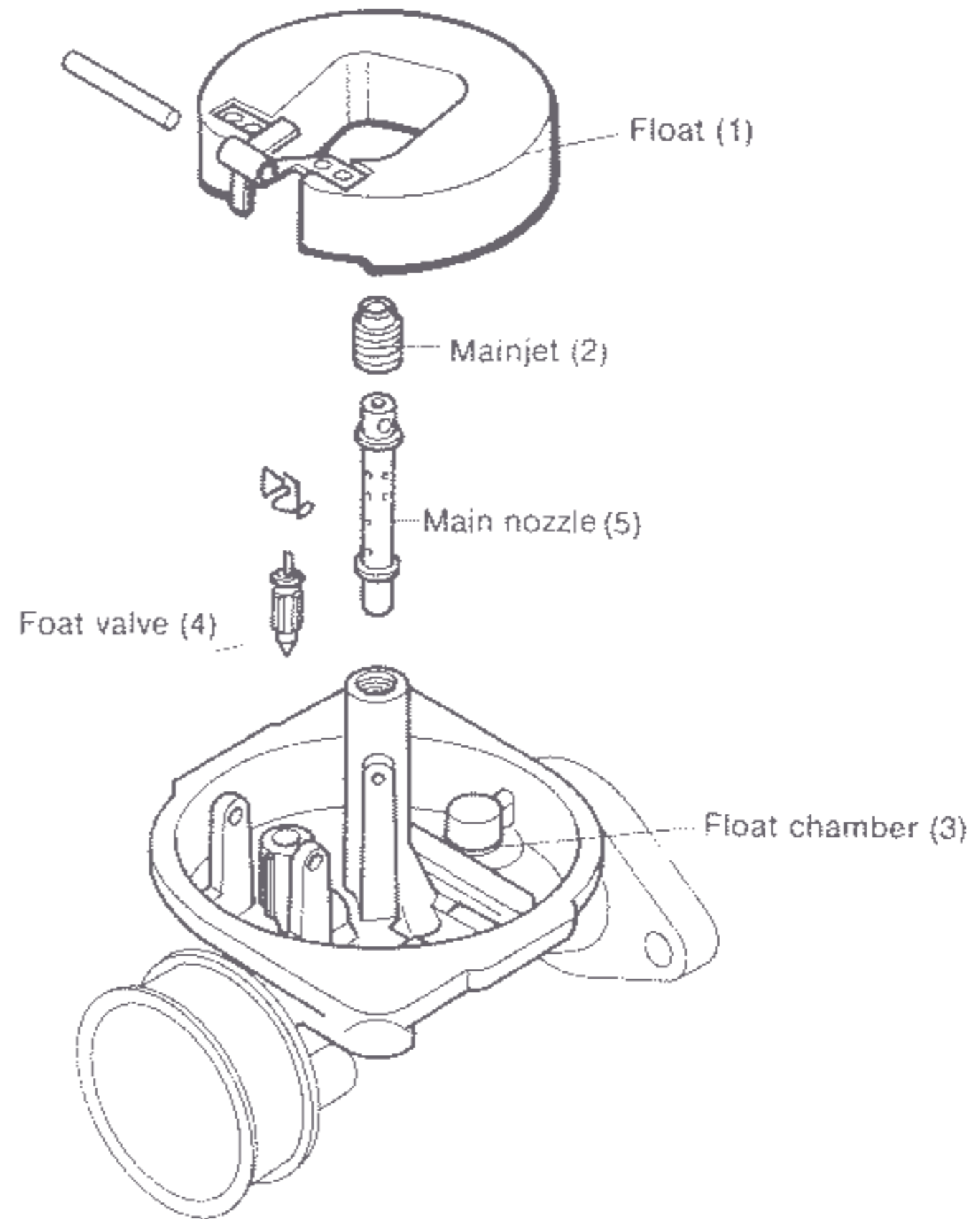

## ● Air cleaner DISASSEMBLY/ASSEMBLY

- ① Remove the drive belt cover
- ② Release the air cleaner case retaining clip
- ③ Pull the air cleaner case out from the rear fork

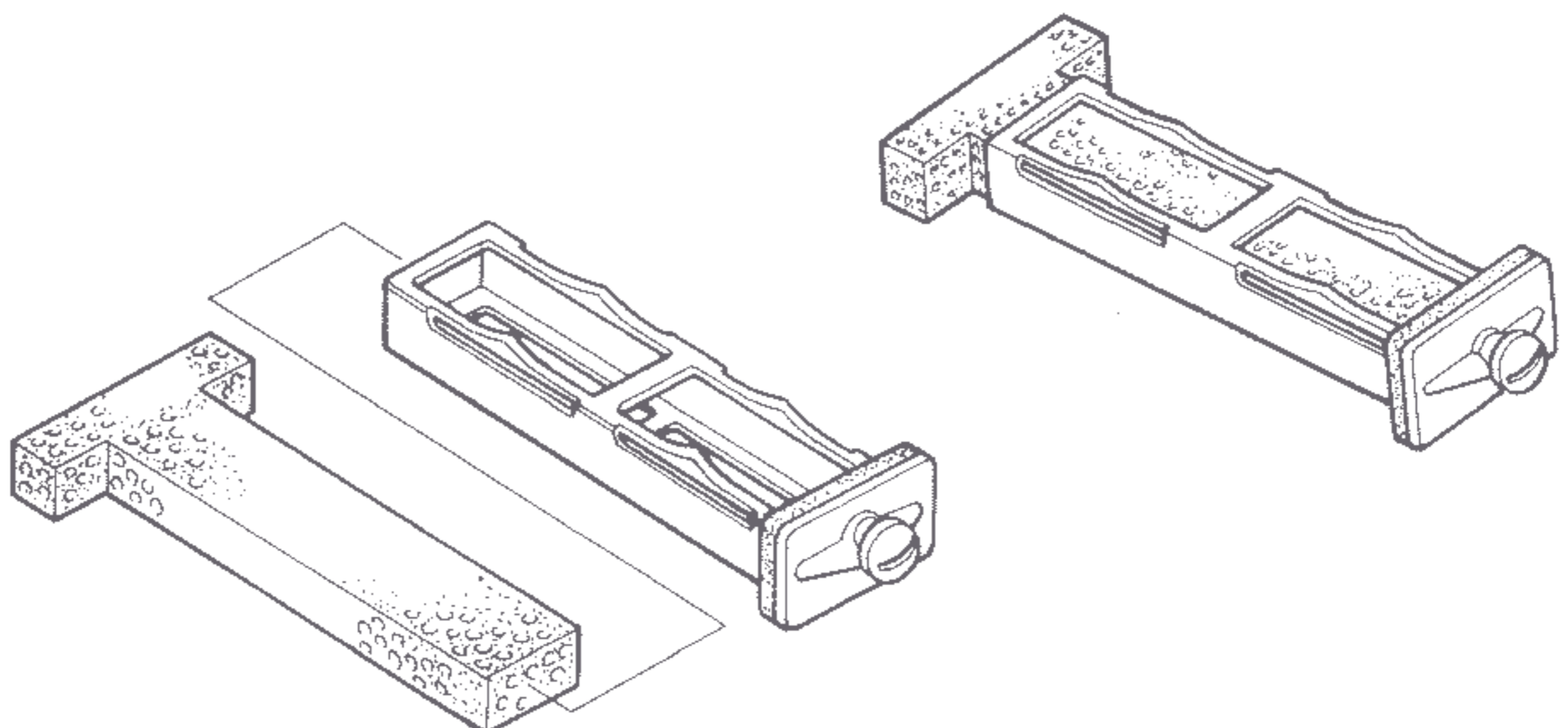

**C. Inspection**

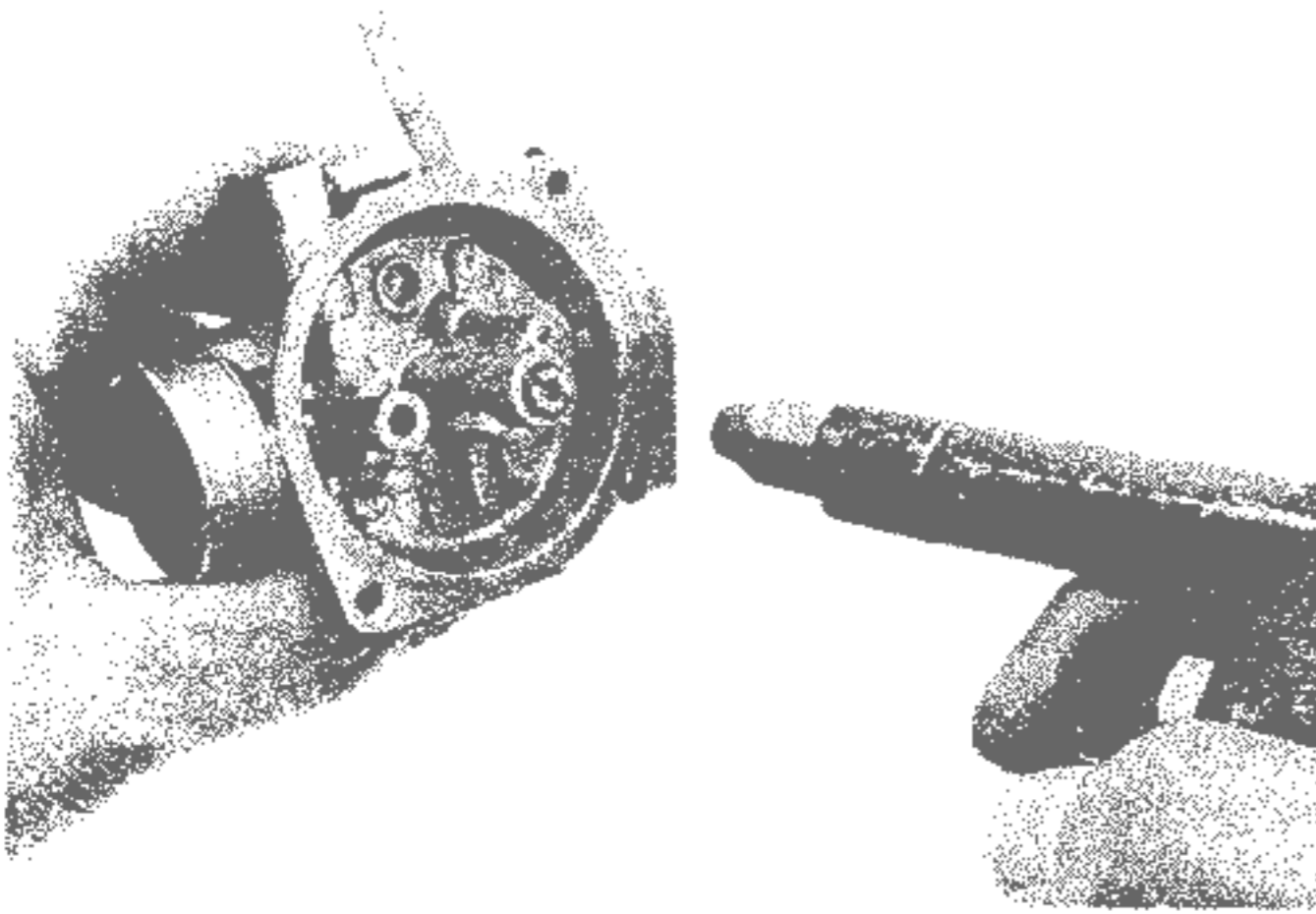

Remove carburetor jets, pilot screw and float.  
With compressed air, blow out all passages in the carburetor body

Float valve inspection

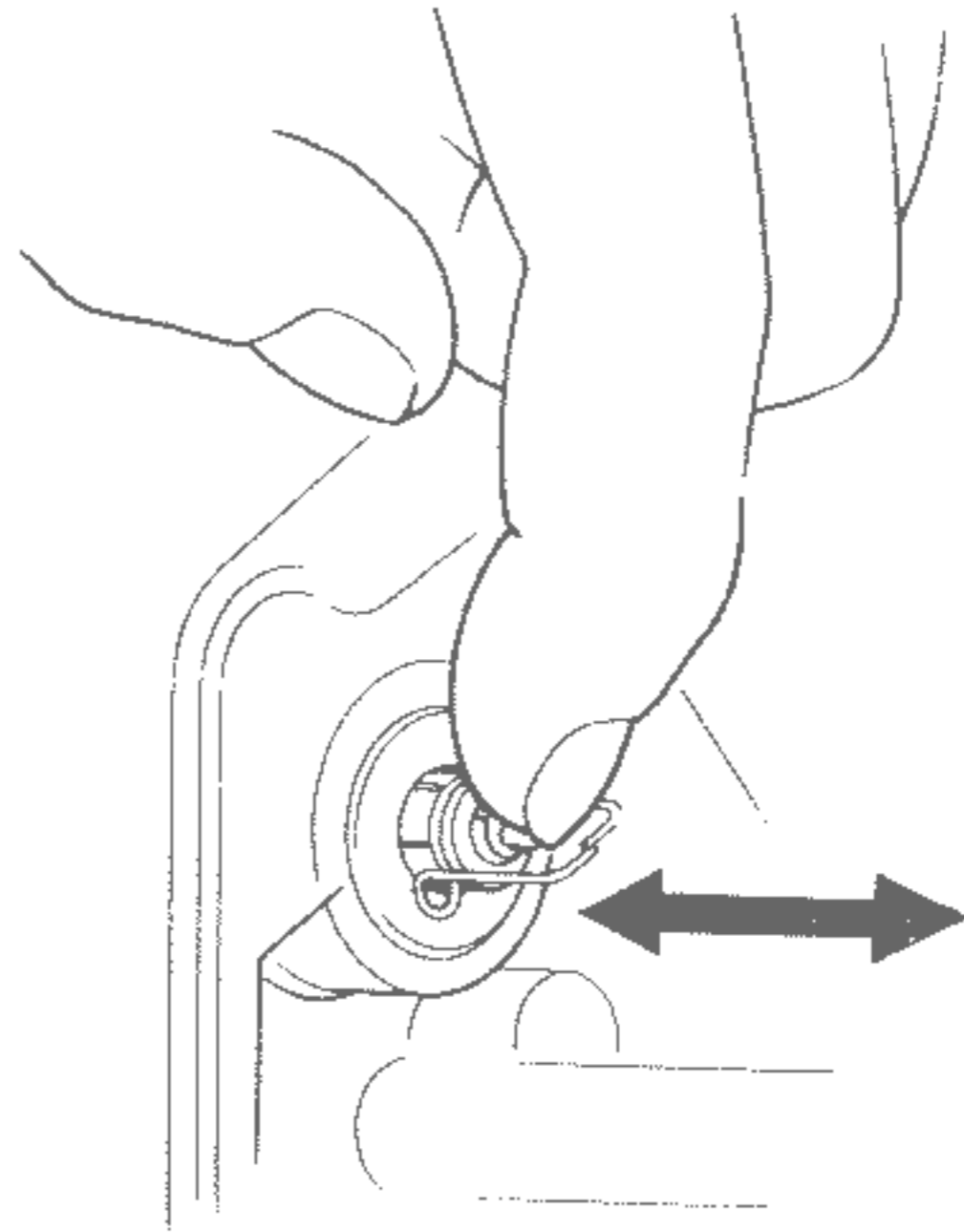

Replace valve if it does not return smoothly

● Measure Float Height

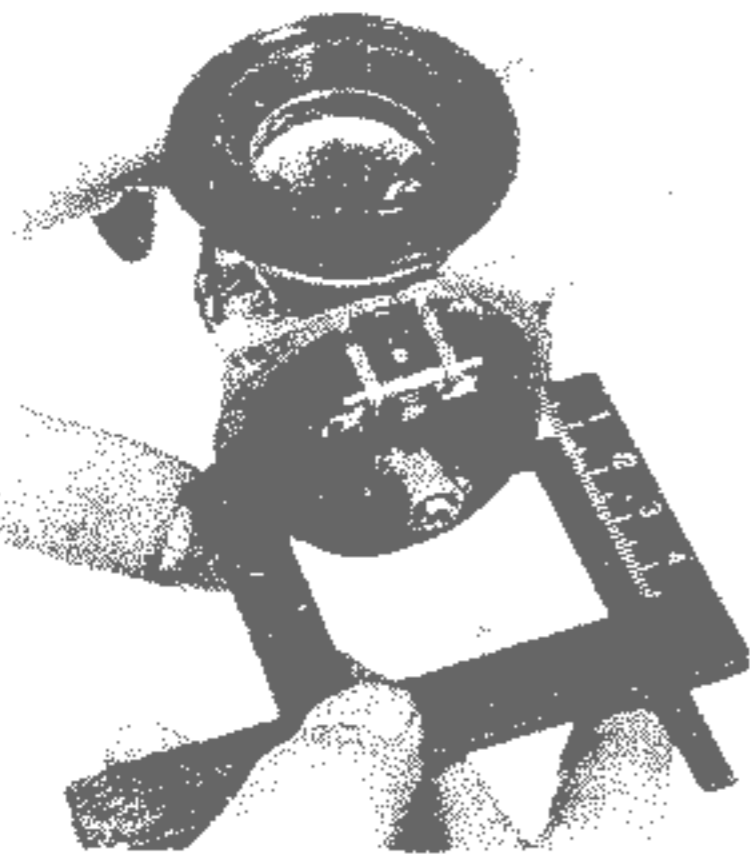

Standard Float level -  
10 mm

Float level gauge  
07401-0010000



## D. Cleaning

Carburetor on the frame

1. Turn the fuel cock "OFF".
2. Drain the carburetor (screw A).
3. Clean the carburetor with compressed air.
4. Reinstall the carburetor on the frame.

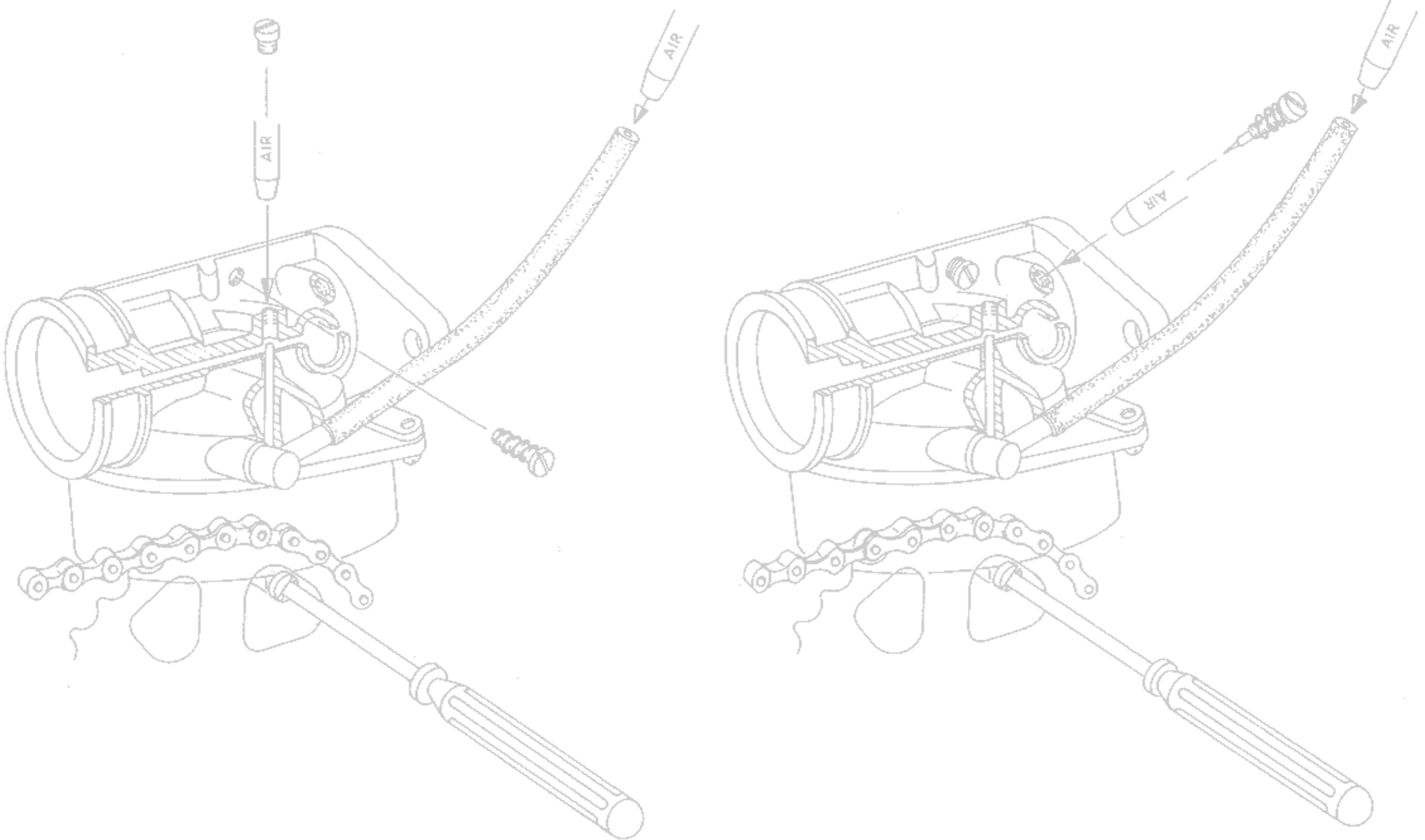

**Remark :** Turn the mixture screw fully in, and after, 1 turn out.  
Start the engine and adjust the carburetor.

Carburetor removed from the frame.

1. Remove the carburetor from the frame and blow compressed air as shown on the figure.
2. Reinstall the carburetor, start the engine and adjust the carburetor as shown above.

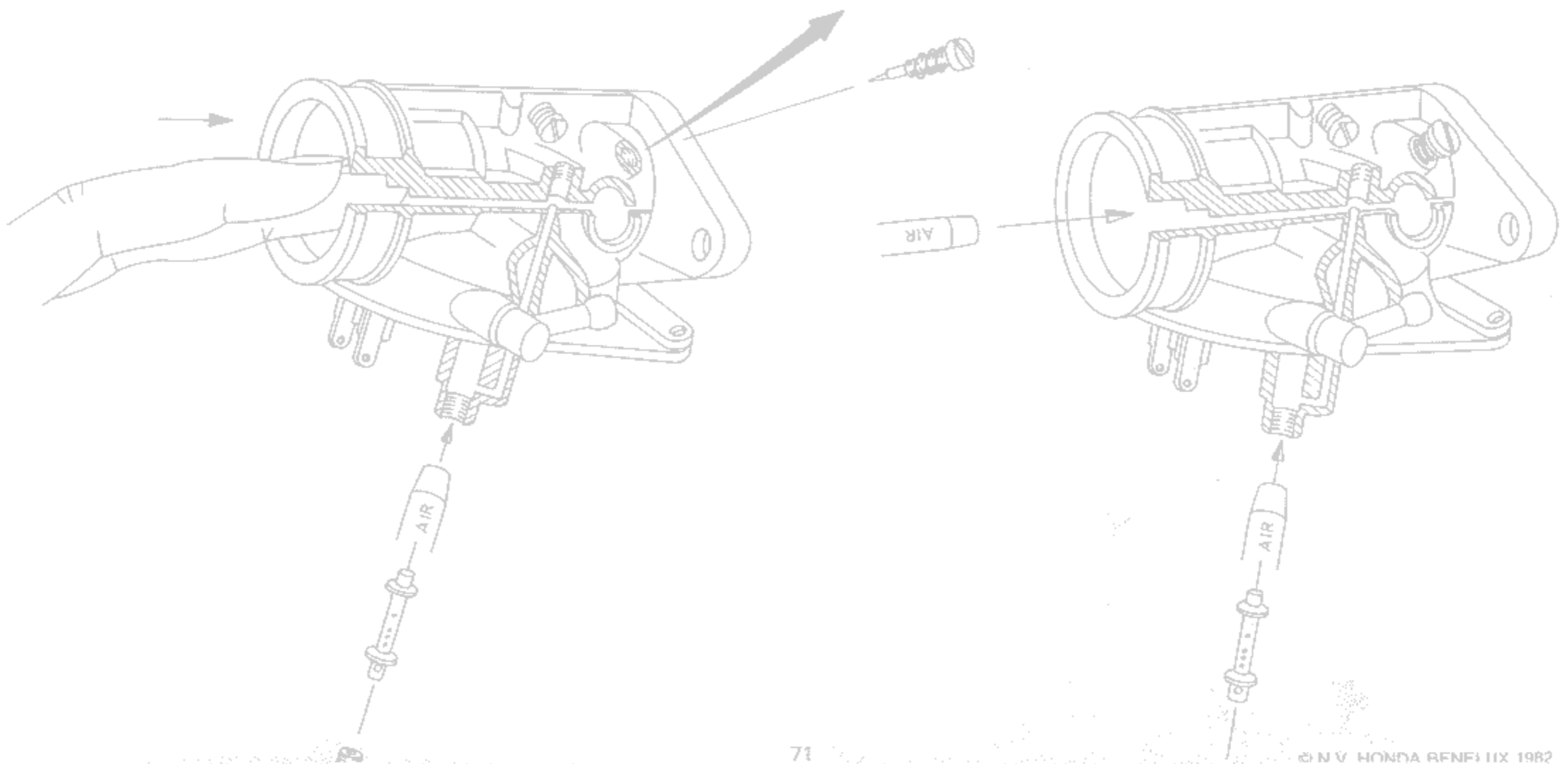



## 11. HANDLEBAR/FRONT SUSPENSION/FRONT WHEEL

|                               |    |
|-------------------------------|----|
| A. Trouble Shooting .....     | 72 |
| B. Disassembly/Assembly ..... | 73 |
| C. Inspection .....           | 76 |

### A. Trouble Shooting

| Symptom                | Probable cause  |
|------------------------|---|
| Hard steering          | Damaged or broken radial ball bearings in steering stem<br>Excessively tightened head top thread<br>Low tire pressure                 |
| Front wheel wobble     | Distorted wheel rim   |
| Pulls to one side      | Bent front fork<br>Unbalanced shock absorbers   |
| Poor brake performance | Worn brake shoe/drum<br>Oil or grease on brake shoe or drum<br>Worn brake cam   |
| Too soft a ride        | Weak shock absorber spring  |
| Front suspension noise | Interference between shock absorber case and frame<br>Interference between shock absorber case and spring.<br>Damaged stopper rubber. |



# HONDA PA50

## B. Disassembly/Assembly

Install handlebar on the lower holders with the punch marks in line with the top of the holders

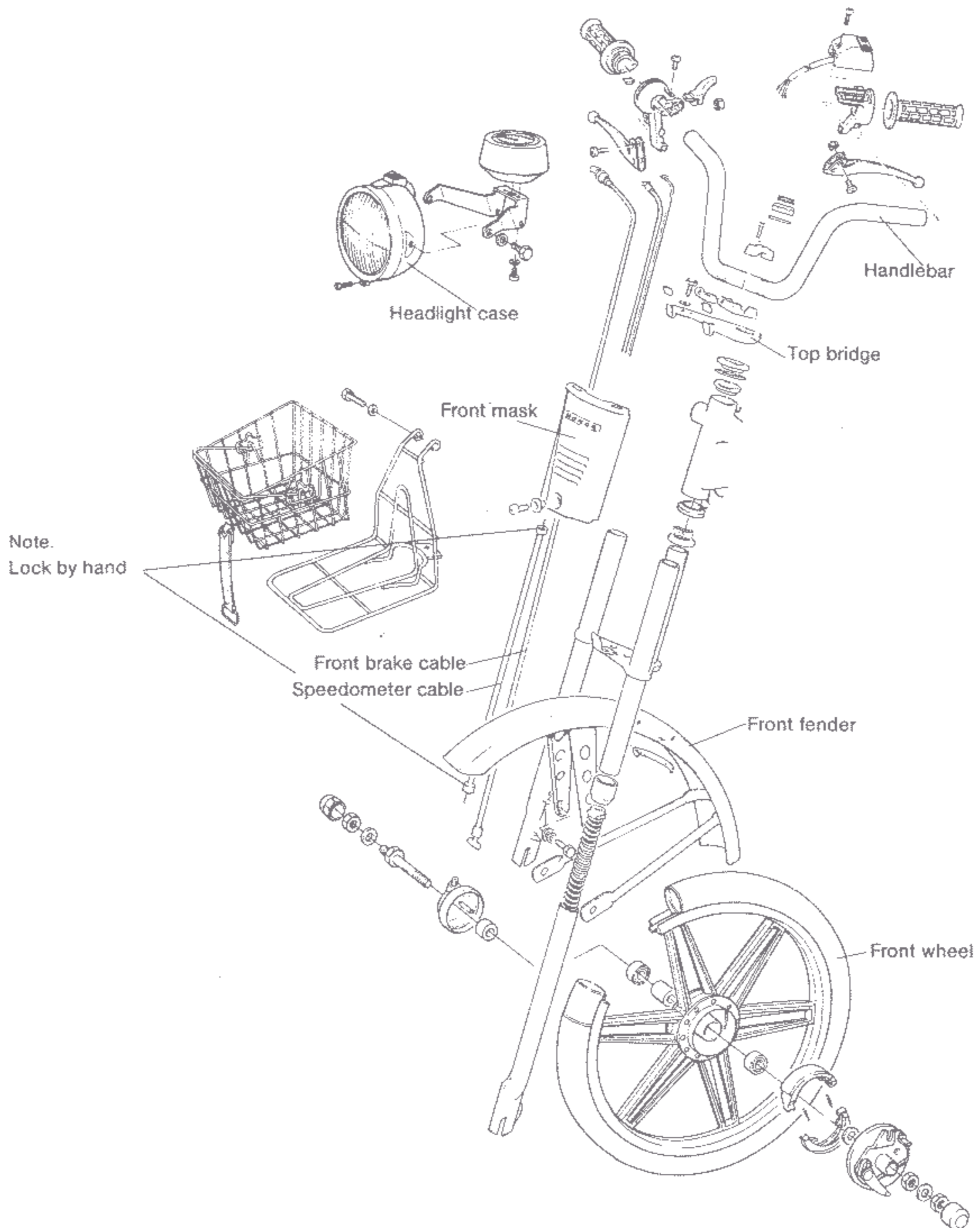



# HONDA PA50

## ● Front Fork Disassembly/Assembly

Pin Spanner Wrench  
07902-2000000

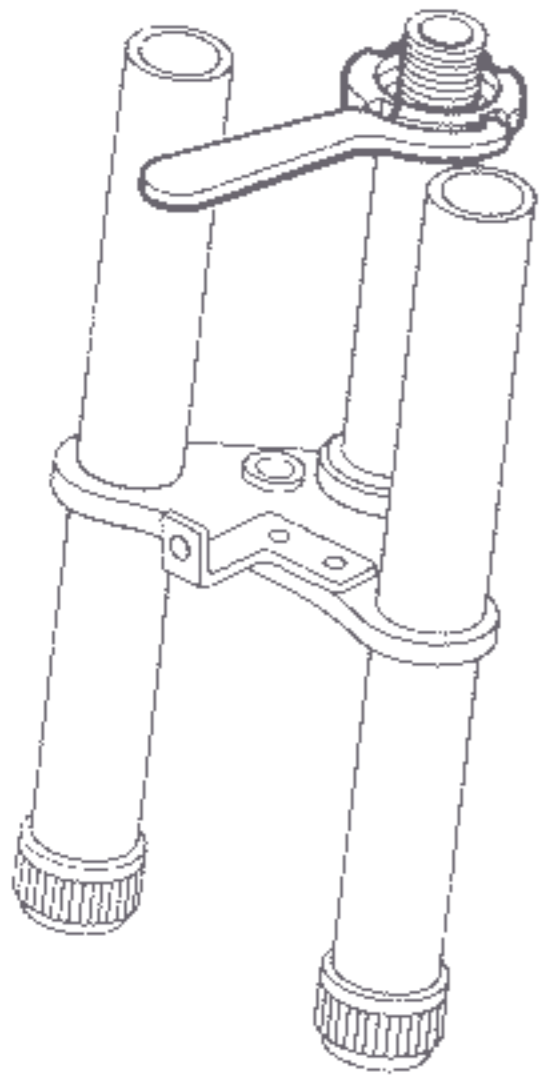

Tighten against steering stem,  
then back off 1/8 turn

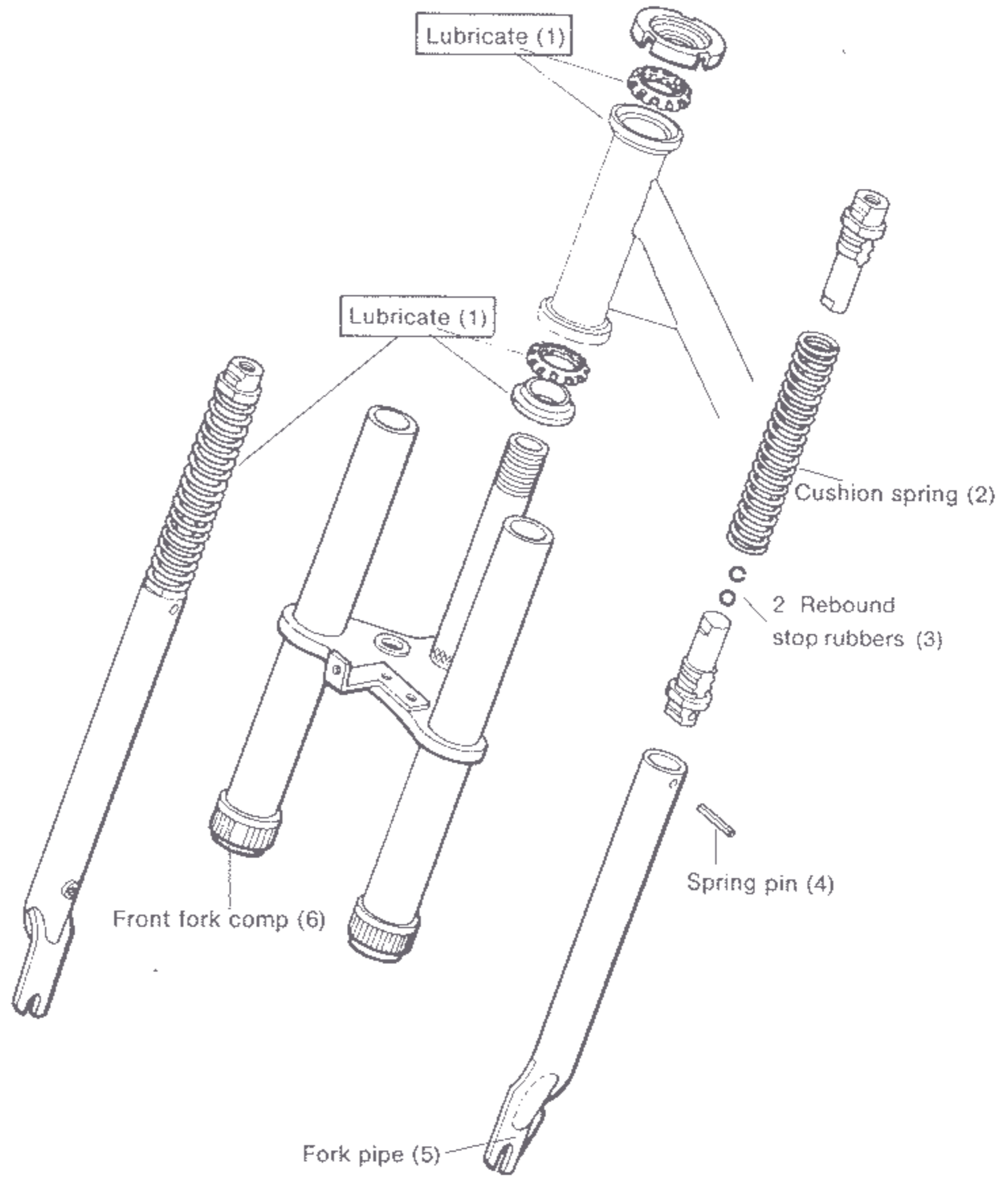

Spring Pin Driver 3.5 mm

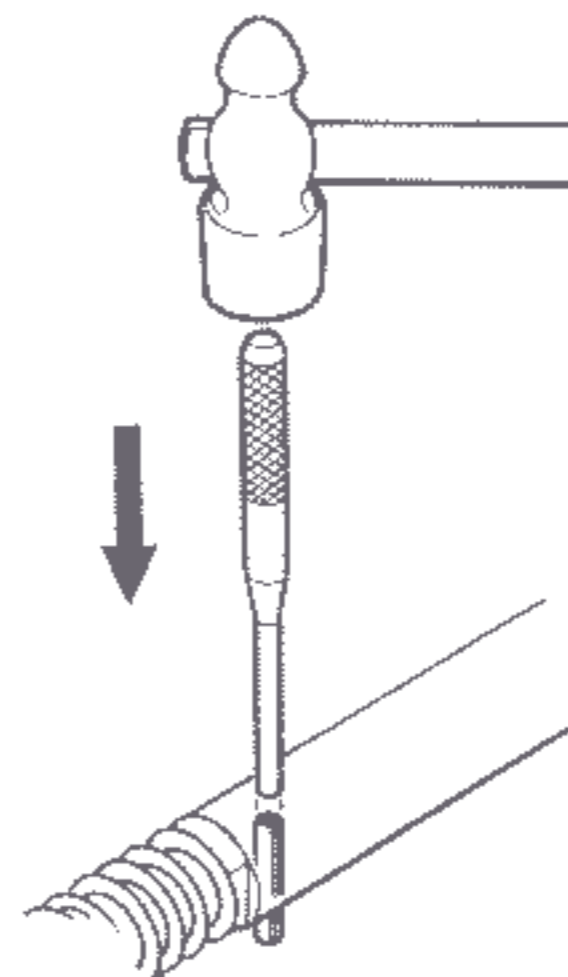



# HONDA PA50

## ● Front Wheel Disassembly/Assembly

Avoid getting oil or grease on the linings and brake drum

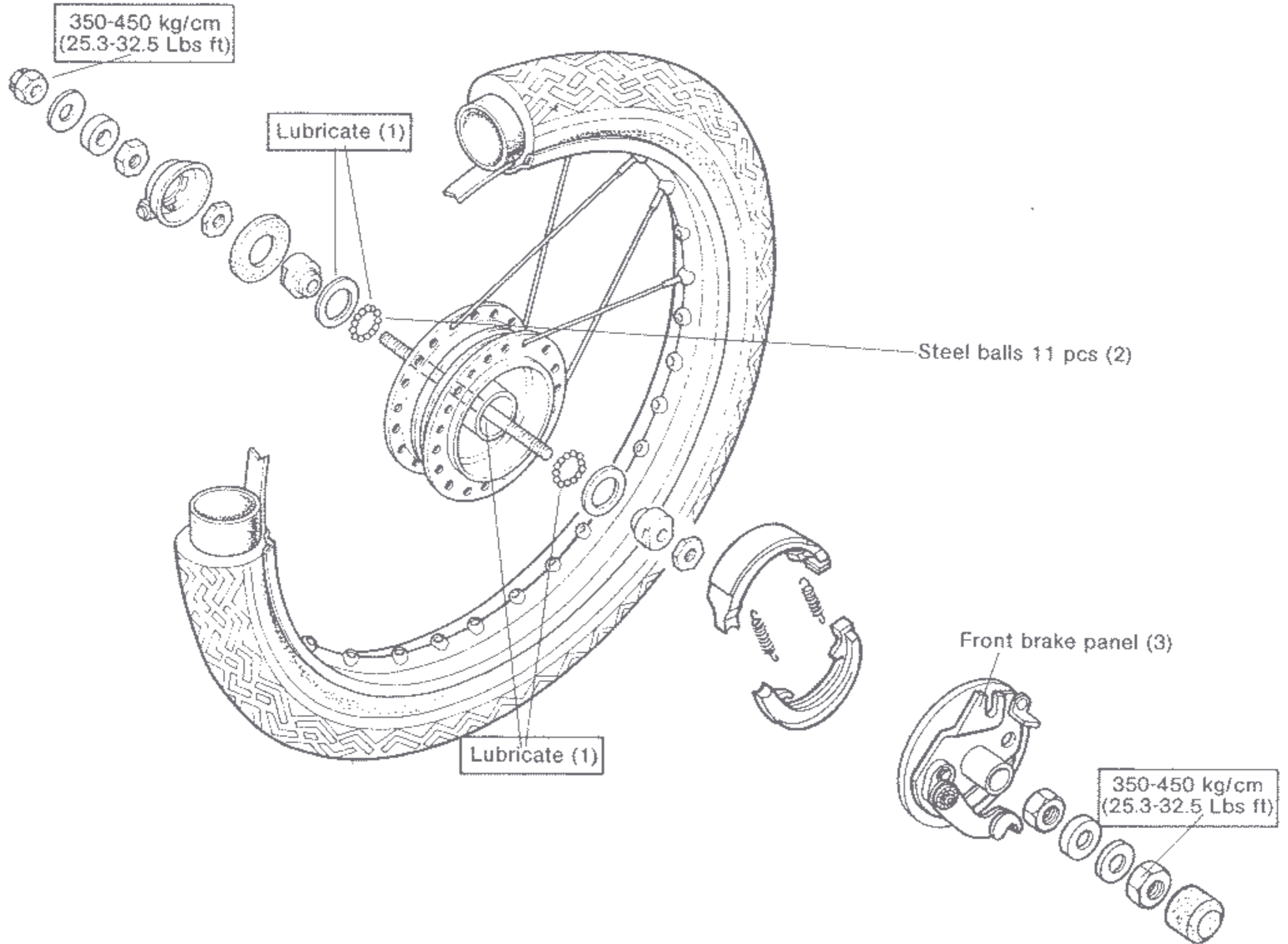



## C. Inspection

- Wheel hub I.D.

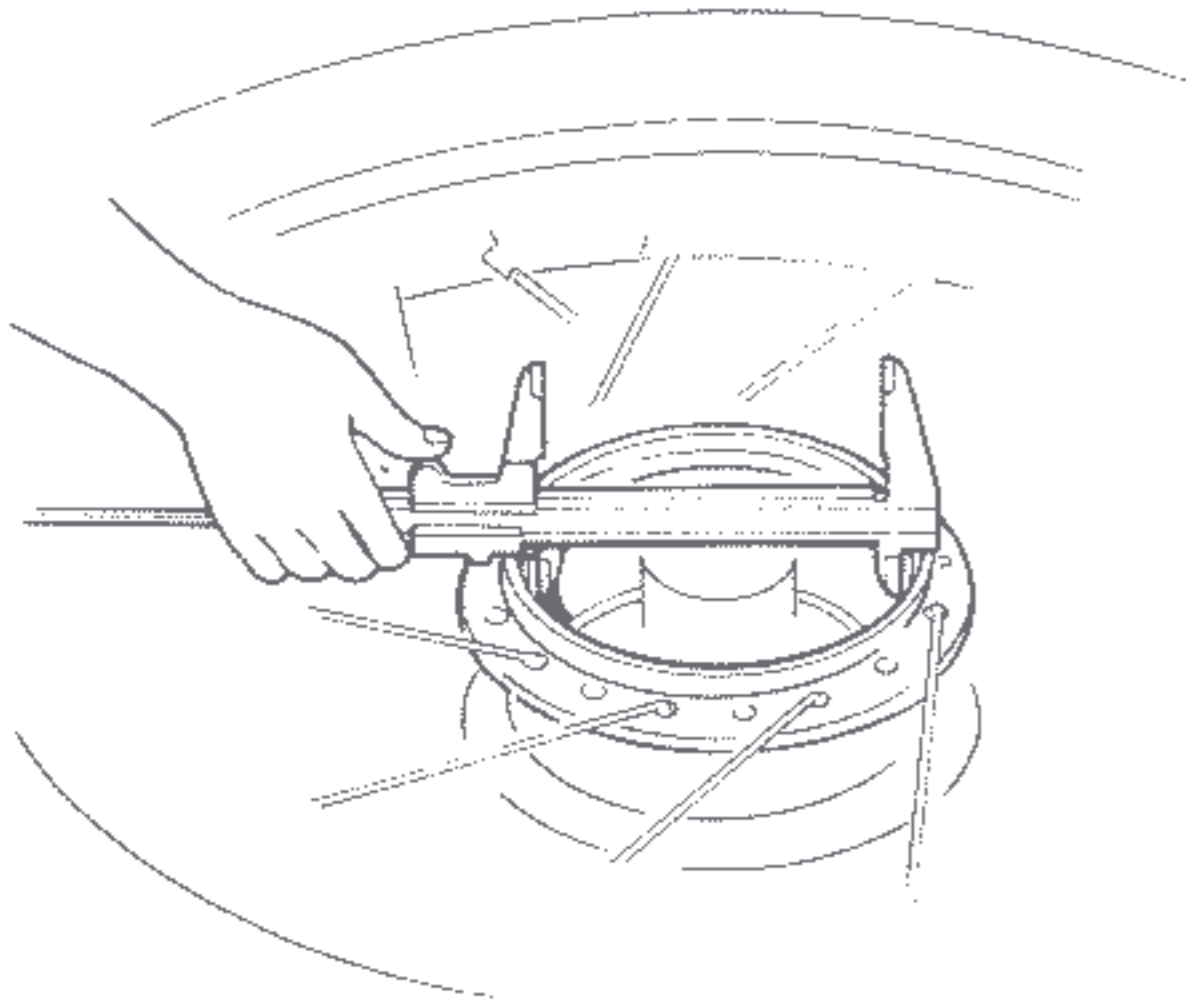

| Standard       | Service Limit |
|----------------|---------------|
| 80.0 - 80.2 mm | 81.0 mm       |

- Brake lining thickness

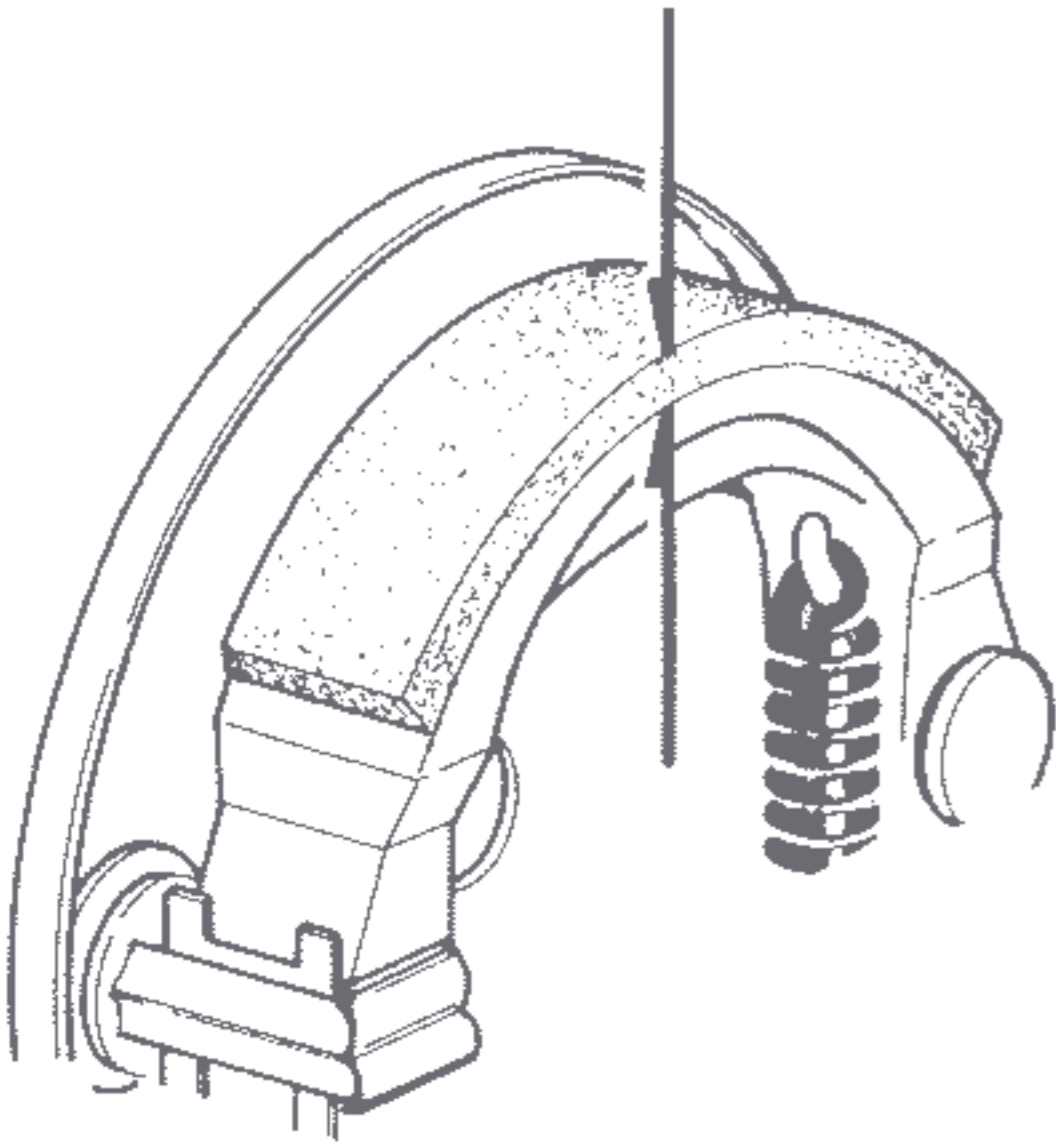

| Standard | Service Limit |
|----------|---------------|
| 3.5 mm   | 2.0 mm        |

### Front Wheel runout

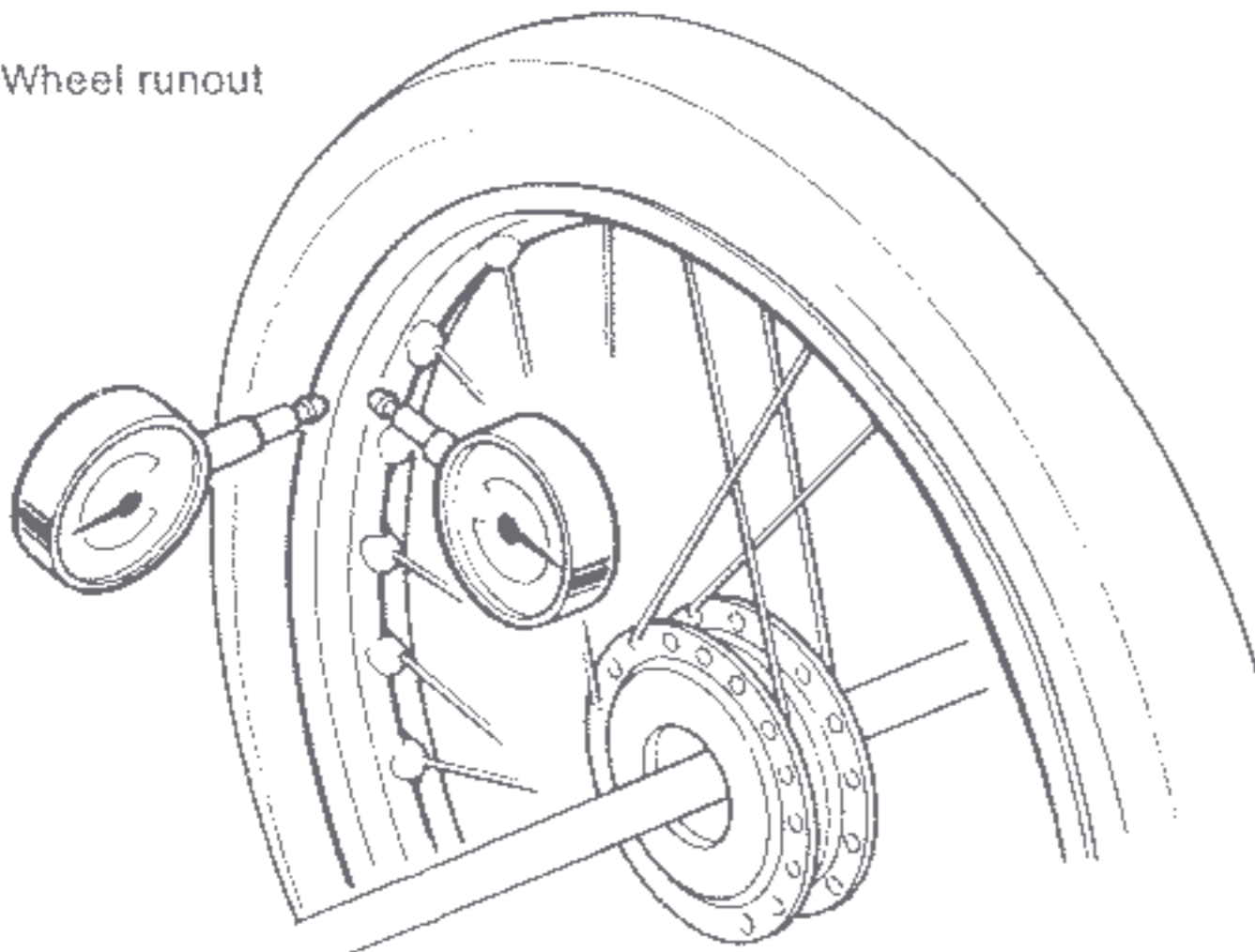

| Standard | Service Limit |
|----------|---------------|
| 1.0 mm   | 2.0 mm        |





● Front Fork spring free length

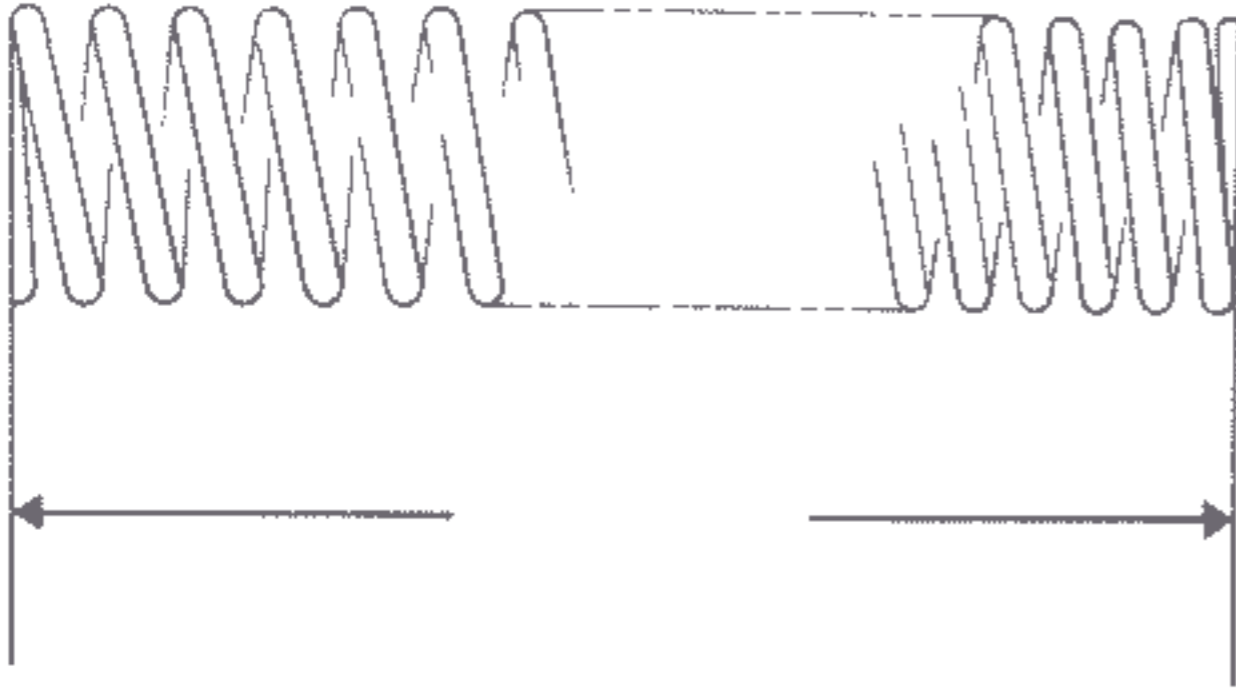

| Standard       | Service Limit |
|----------------|---------------|
| 190,5-196,5 mm | 173 mm        |



## 12. REAR WHEEL

|                               |    |
|-------------------------------|----|
| A. Trouble Shooting .....     | 78 |
| B. Disassembly/Assembly ..... | 80 |
| C. Inspection .....           | 81 |

### A. Trouble Shooting

| Symptom                | Probable cause  |
|------------------------|---|
| Poor brake performance | Worn brake shoe/drum<br>Oil or grease on brake shoe or drum<br>Worn brake cam |
| Wheel wobble           | Distorted wheel rim   |



## Rear Wheel Removal

- ① Remove the belt cover and chain
- ② Disconnect the rear brake cable at the rear brake arm
- ③ Remove the chain at the driven sprocket after loosening the tensioner bolt
- ④ Remove the four rear fork bolts
- ⑤ Remove the drive belt
- ⑥ Remove the rear wheel

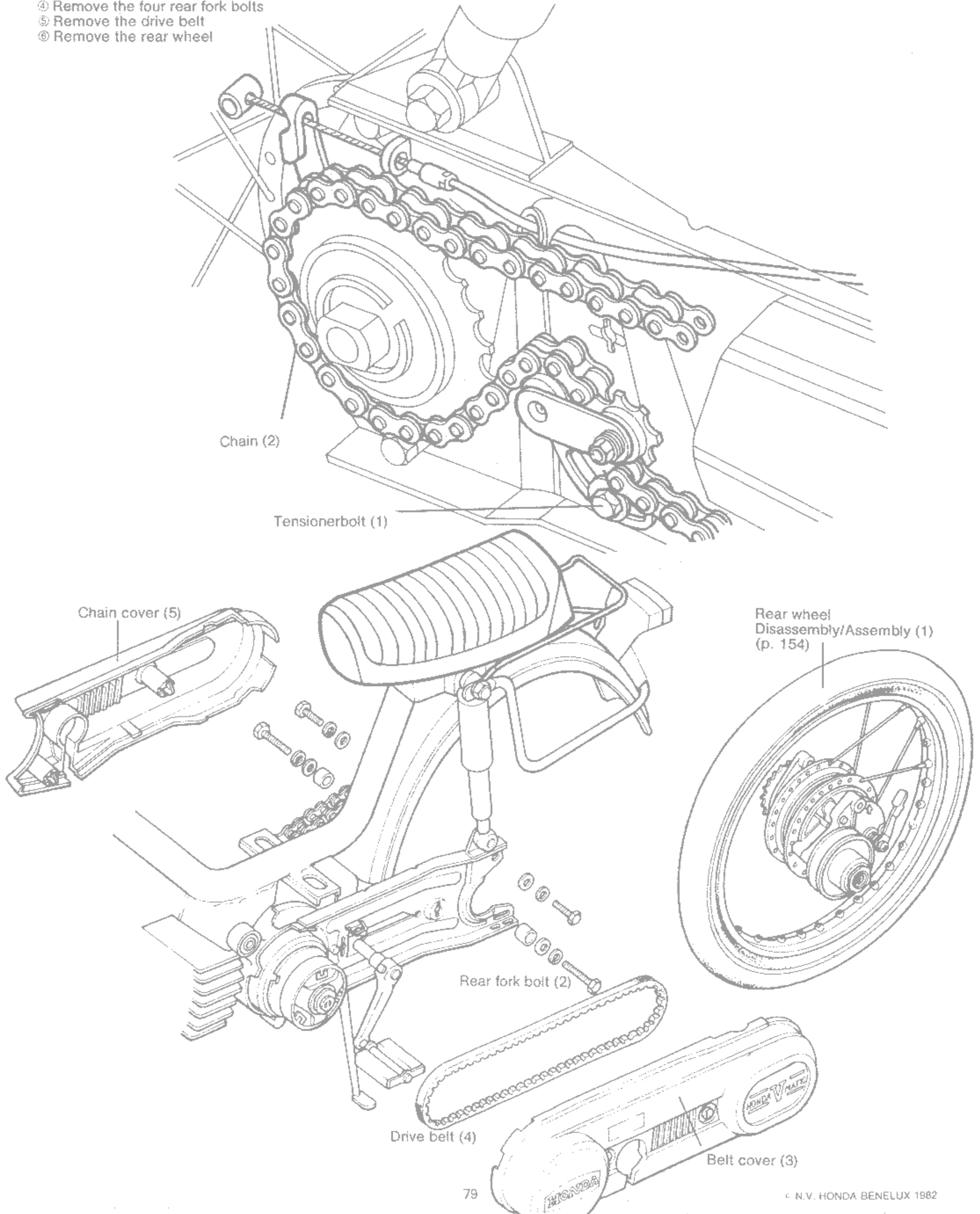



## B. Rear Wheel Disassembly/Assembly

- ① Turn the center nut with driven sprocket counterclockwise
- ② Remove the rear brake
- ③ Remove the reduction gear box

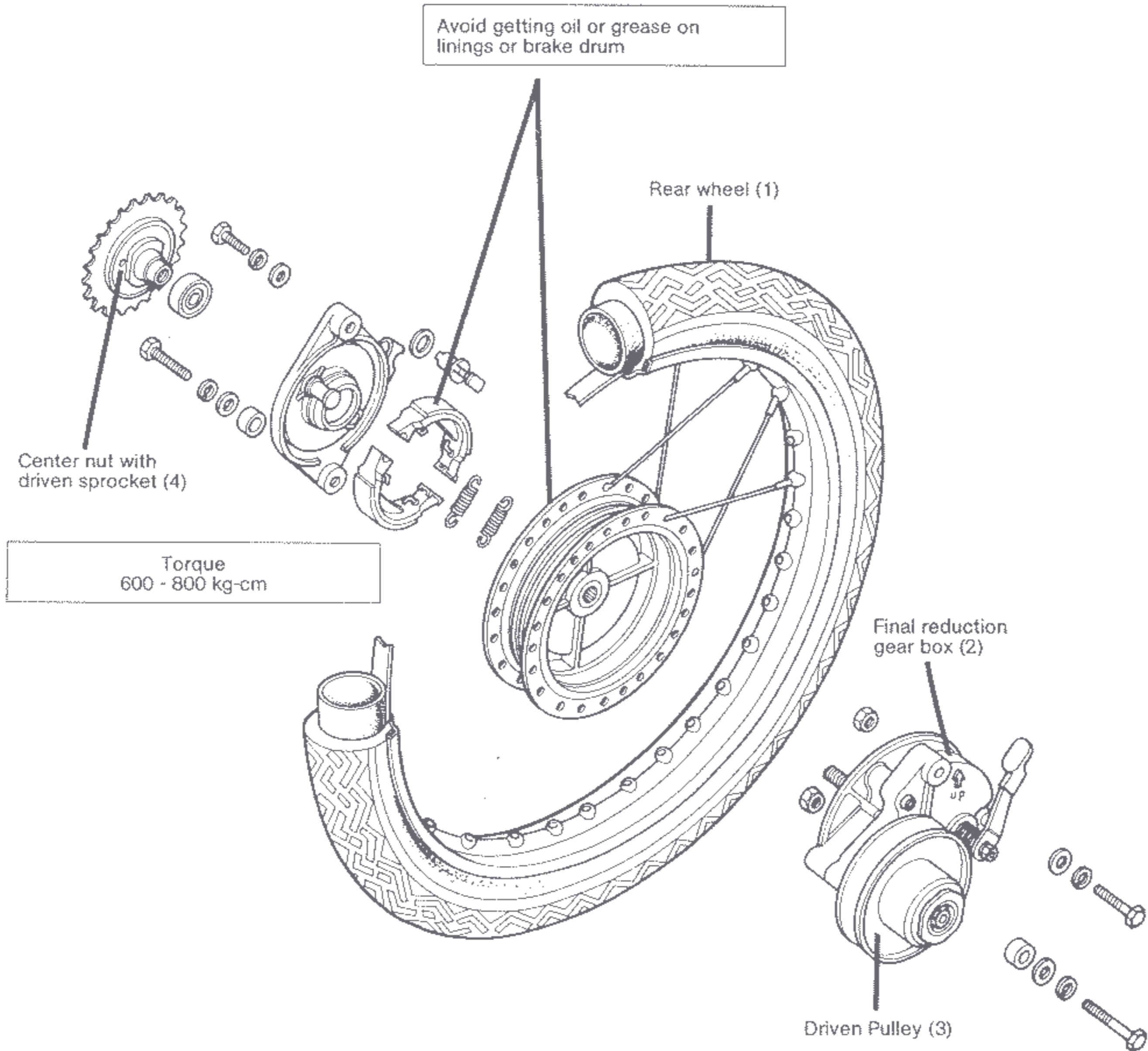



# HONDA PA50

## C. Inspection

- Wheel Hub I.D.

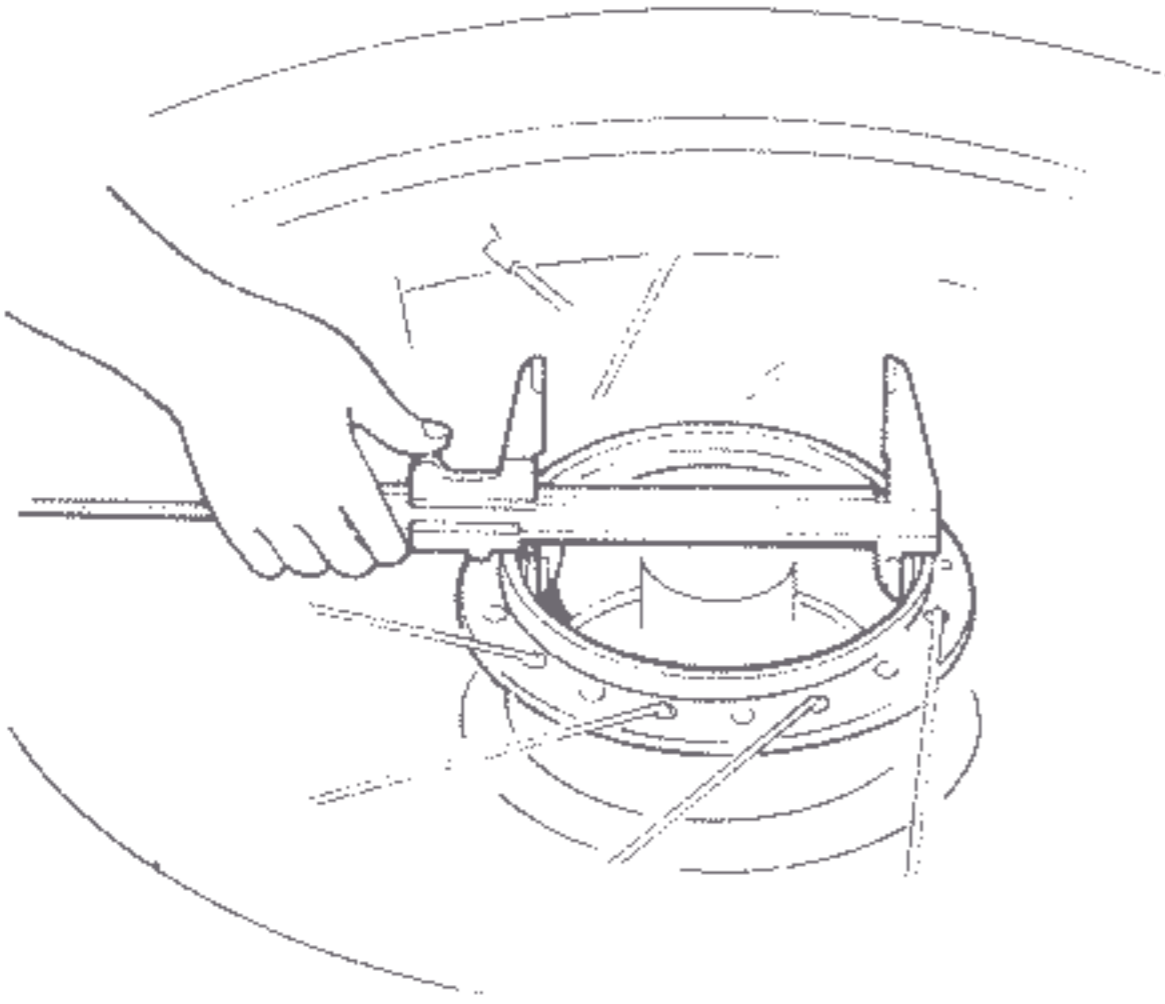

| Standard       | Service Limit |
|----------------|---------------|
| 80.0 - 80.2 mm | 81.0 mm       |

- Brake lining thickness

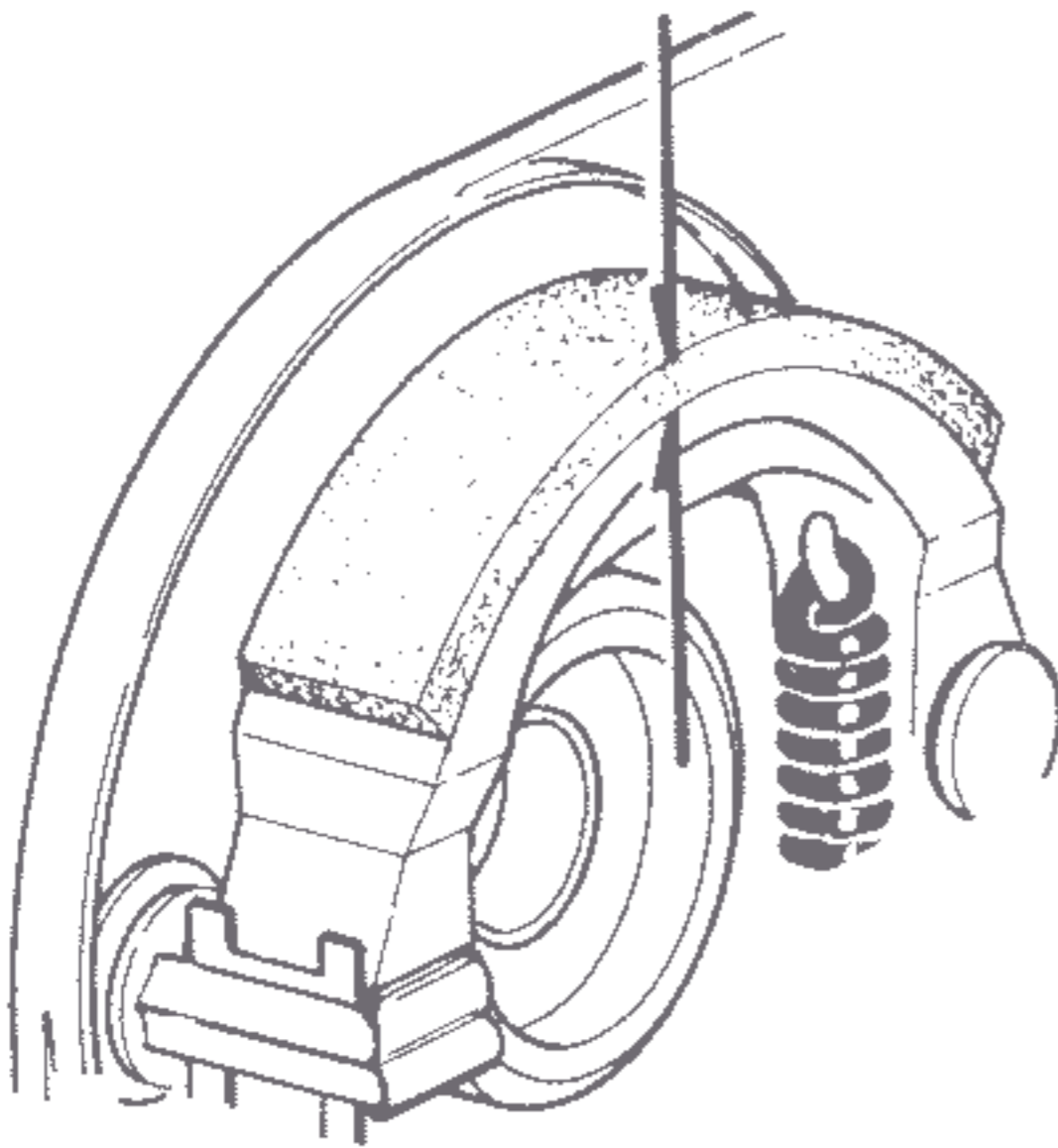

| Standard | Service Limit |
|----------|---------------|
| 3.5 mm   | 2.0 mm        |

- Rear Wheel Runout

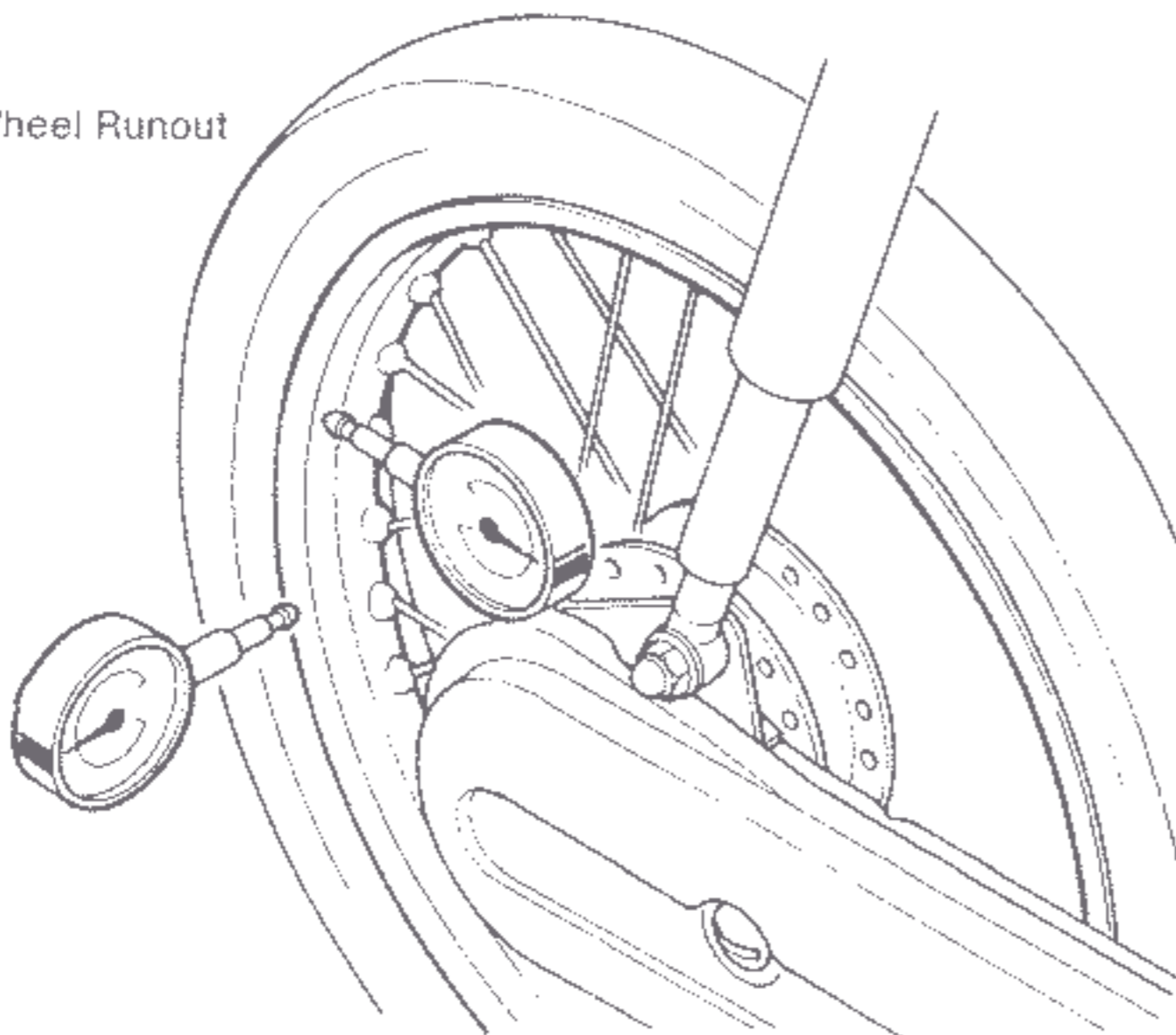

| Standard | Service Limit |
|----------|---------------|
| 1.0 mm   | 2.0 mm        |



## 13. FINAL REDUCTION

|                               |    |
|-------------------------------|----|
| A. Trouble shooting .....     | 82 |
| B. Disassembly/Assembly ..... | 83 |
| C. Inspection .....           | 84 |

### A. Trouble shooting

| Symptom   | Probable cause  |
|-----------|---|
| Noise     | Worn or seized gear<br>Excessive rattle in ball bearing |
| Oil leaks | Excessive oil in case<br>Defective oil seal             |



# HONDA PA50

## B. DISASSEMBLY / ASSEMBLY

- ① Remove the reduction gear box from the rear wheel.
- ② Remove the drain bolt and drain the gear oil.
- ③ Remove the five screws from the reduction cover.

**NOTE:**

Set the shift lever at the pedal driving position.

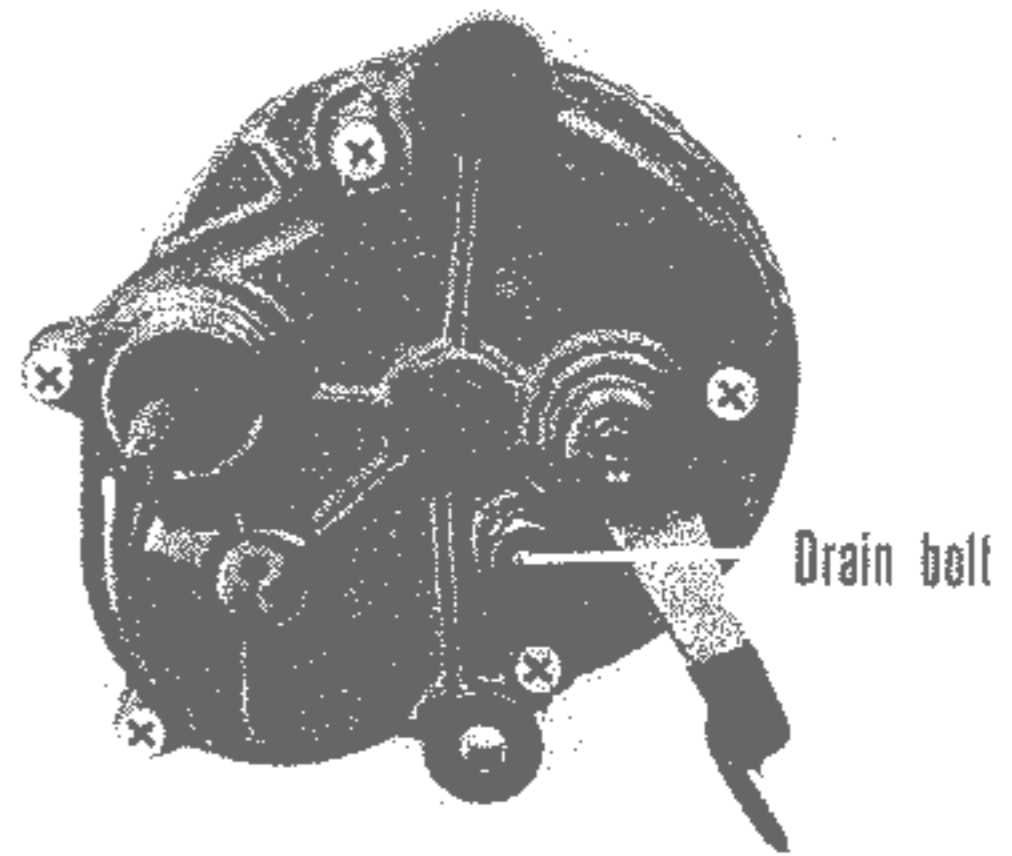

Gear oil SAE 90  
Capacity 75 cc.

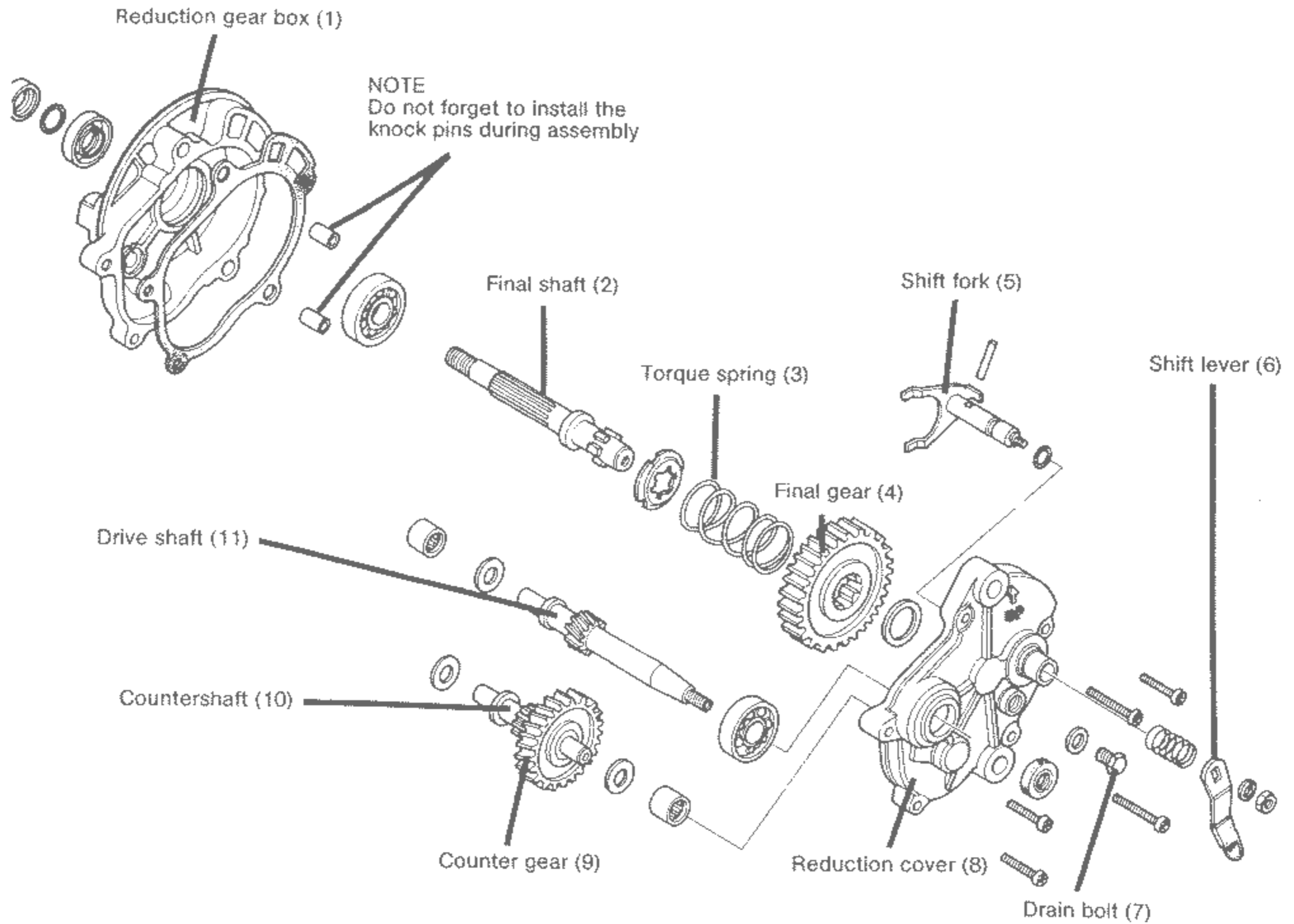

Assembly  
Do not damage the oil seal when installing the drive and final shaft.

**C. Inspection**

● Check for damage and wear.

● Check bearing play.

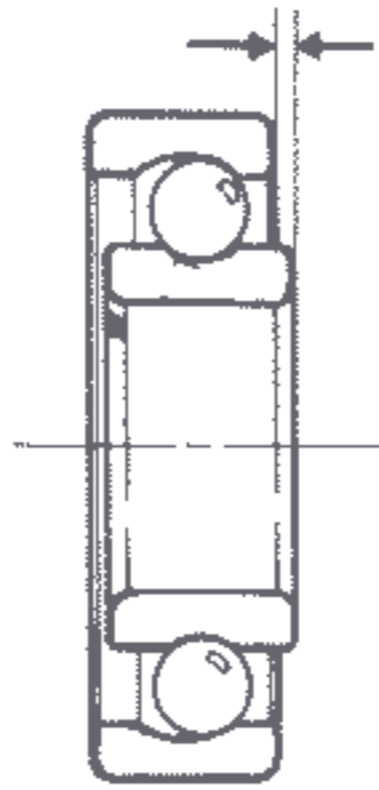
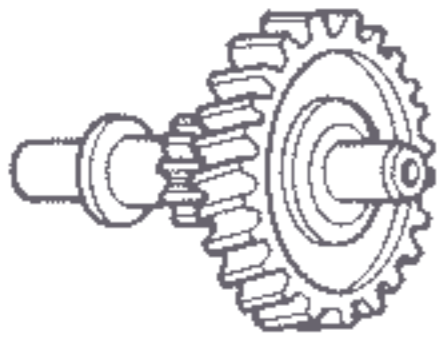

Excessive play (1)  
(replace)

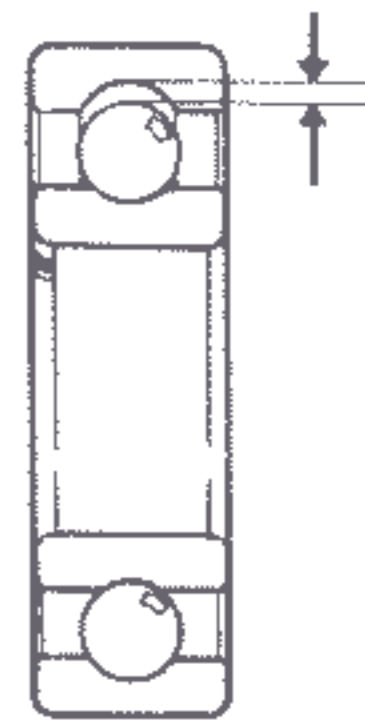

Excessive play  
(replace)





## 14. FUEL TANK / REAR SHOCK ABSORBER

### ● Fuel filter removal.

- 1 Turn the fuel valve lever to "Off".
- 2 Remove the fuel valve cap.
- 3 Pull the fuel filter out.

### ● Fuel strainer removal.

- 1 Remove the fuel tube band at carburetor and drain gasoline.
- 2 Loosen the fuel valve setting nut, and remove the fuel valve.

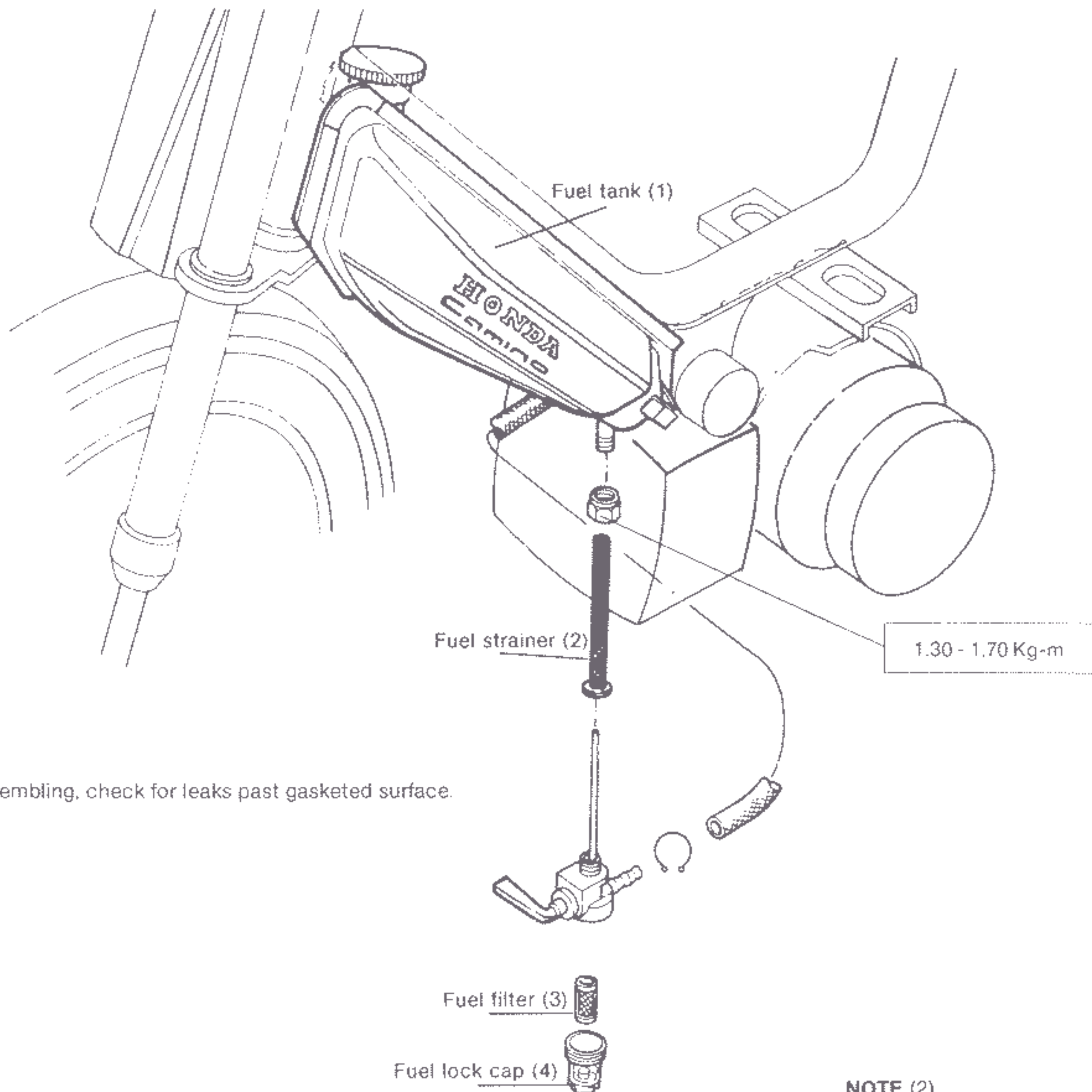

### NOTE (1)

After assembling, check for leaks past gasketed surface.

### NOTE (2)

Clean filter and strainer in solvent.



## Inspection

- Rear cushion spring Fre lenght

| Standard | Service limit |
|----------|---------------|
| 226.9 mm | 194.2 mm      |

After installing check operation.

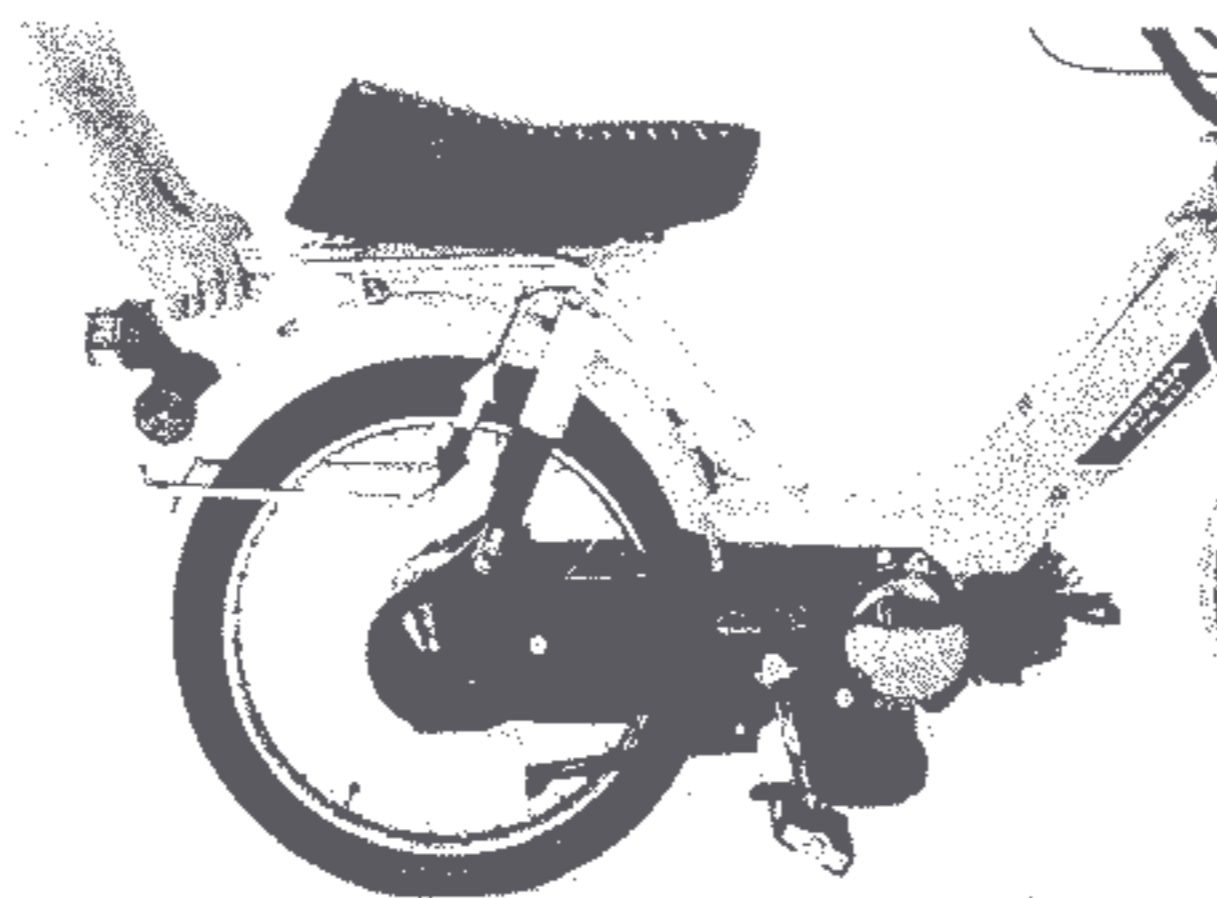



# HONDA PA50

## 15. ELECTRICAL

- Electrical inspection.

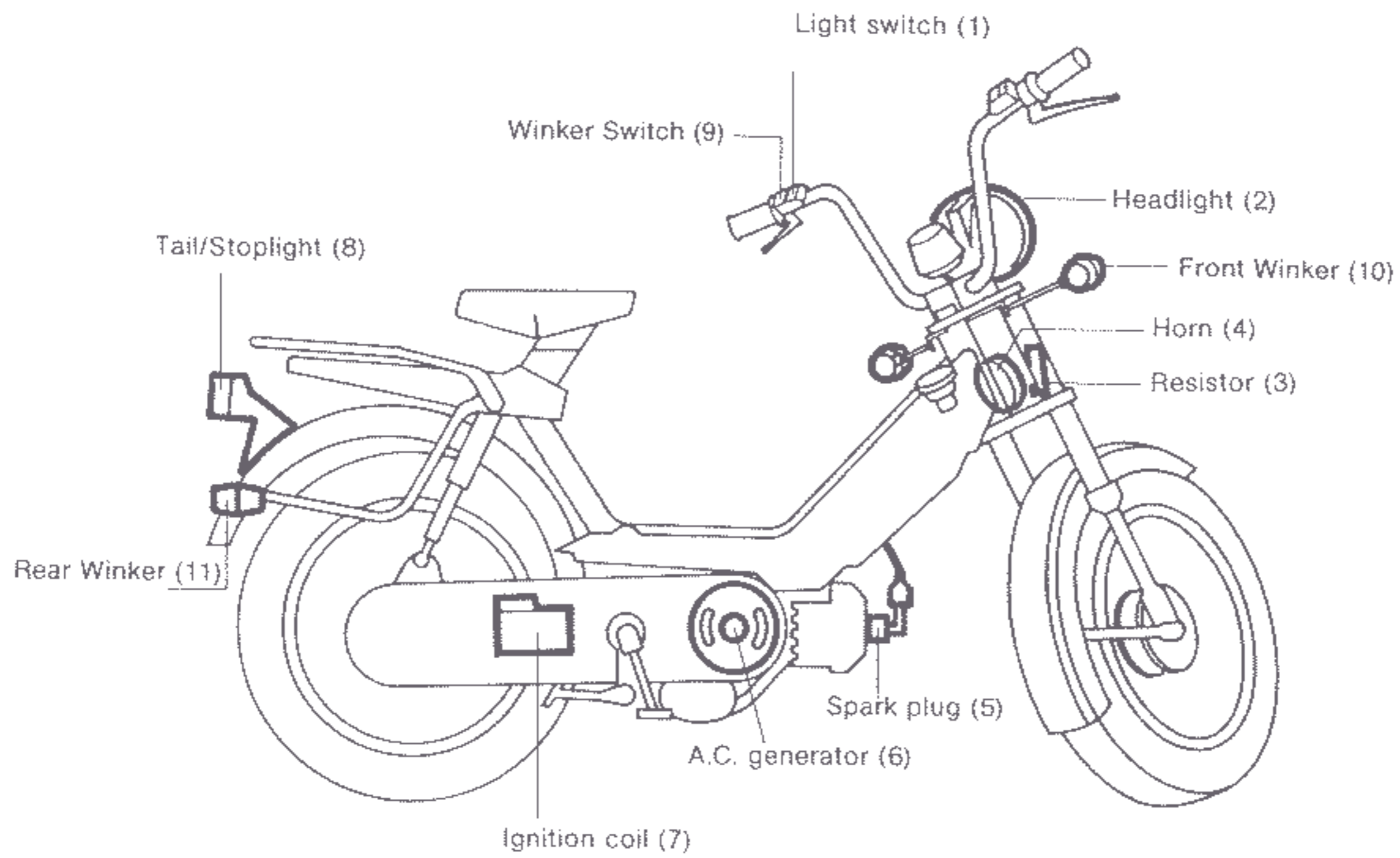

Note:  
To load the battery for the first time,  
ride 20 minutes without using the wipers.



## Inspection

- Ignition coil

### 3. Point spark test

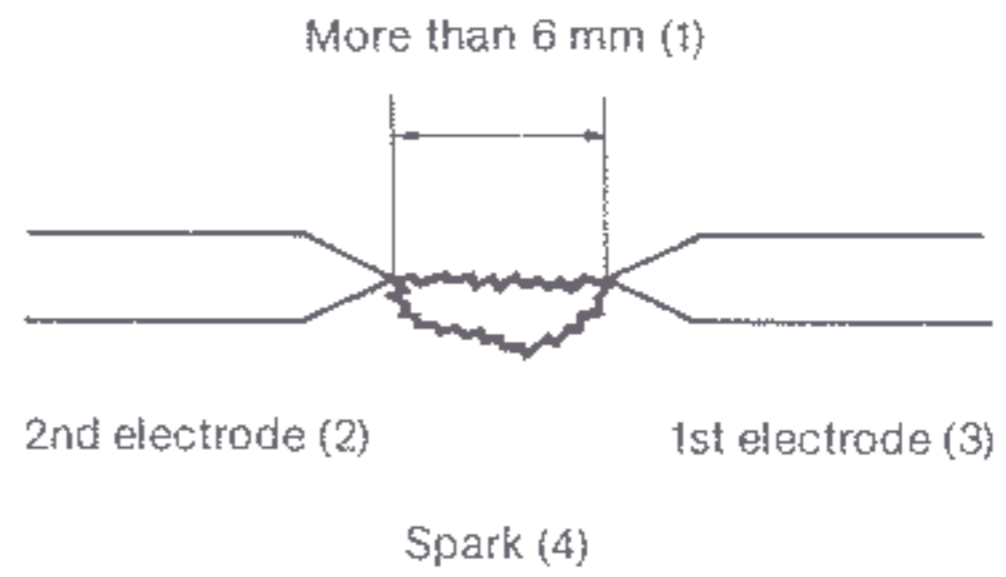
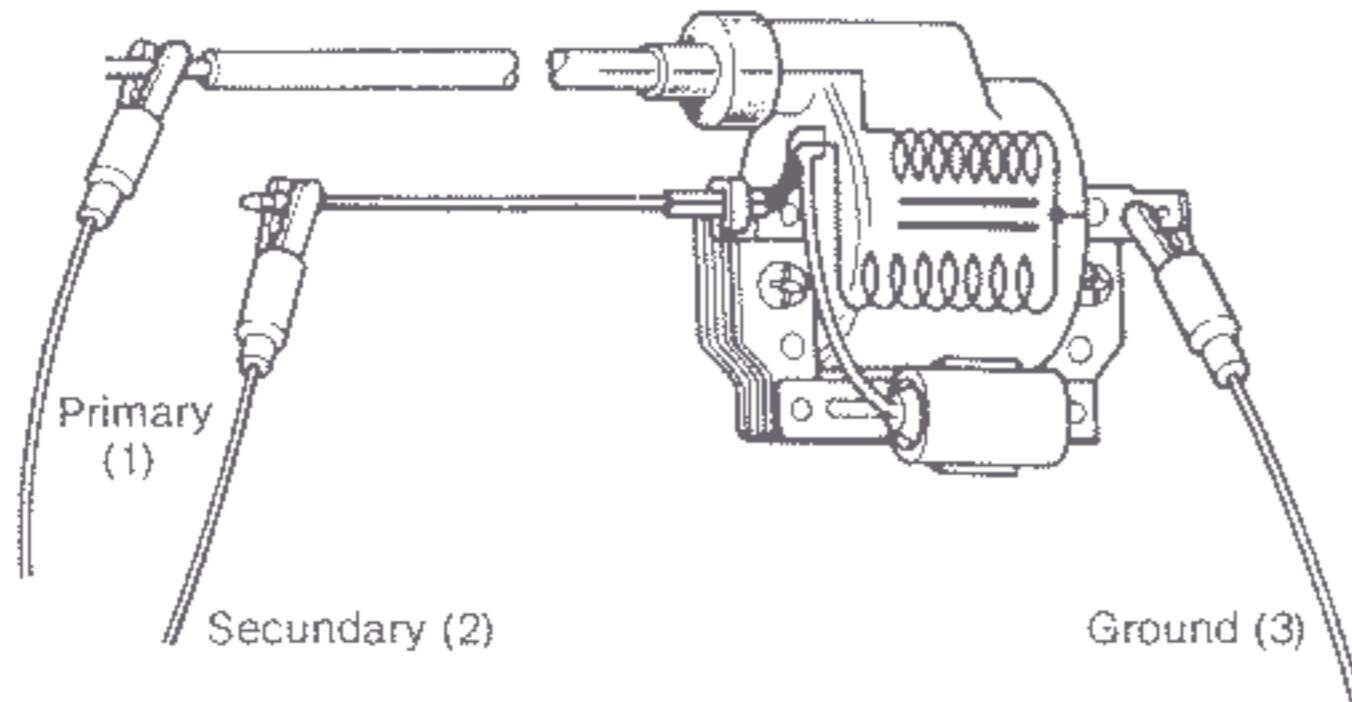

Connect according to service tester instructions.

Coil is normal if spark jumps 6 mm electrode gap on tester.

- Continuity test

Check for continuity

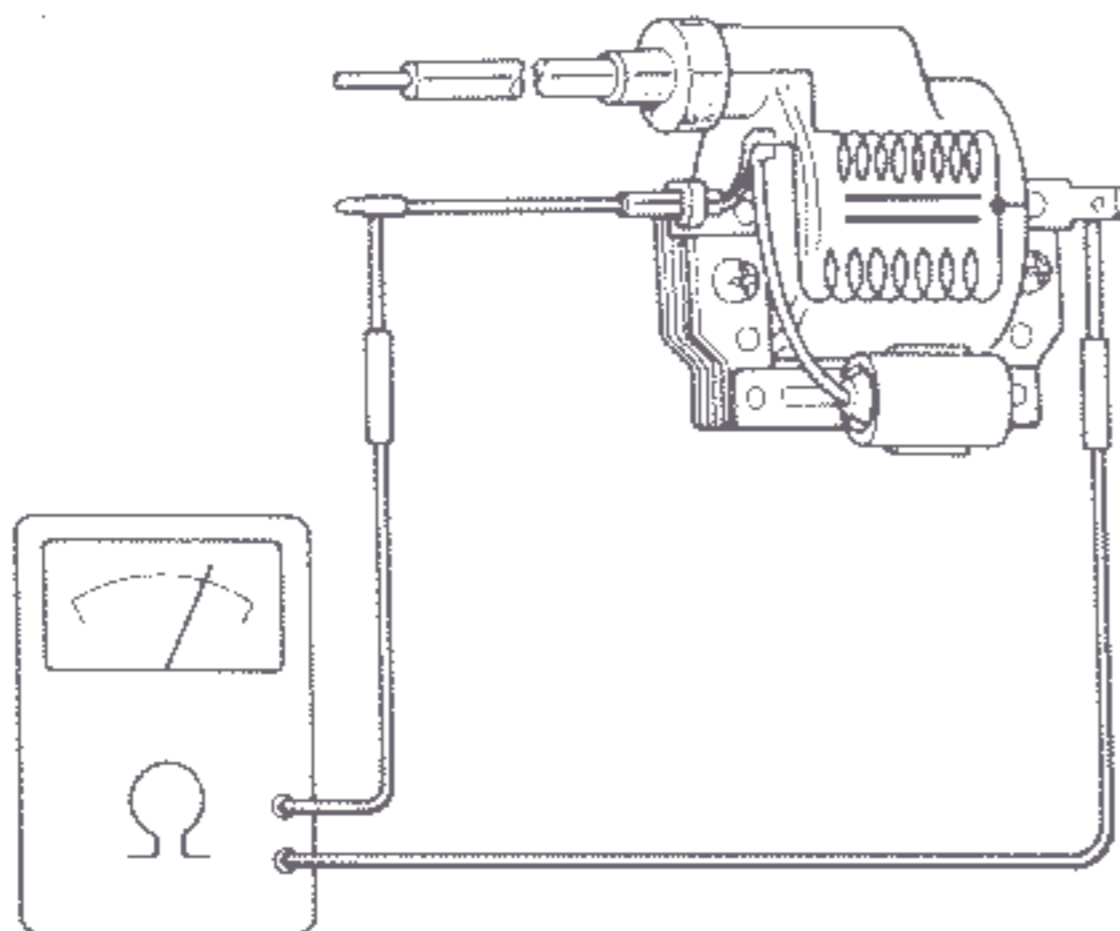

- Resistor

Continuity test

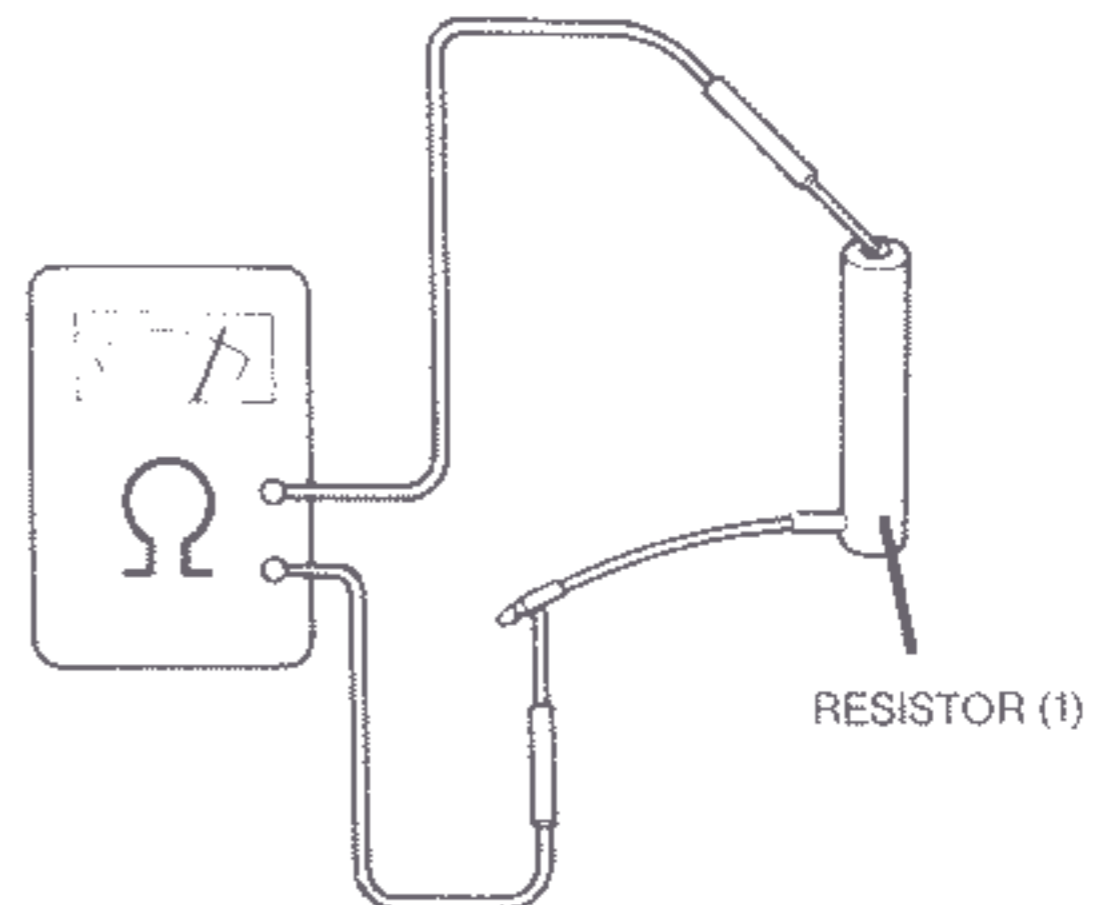



# HONDA PA50

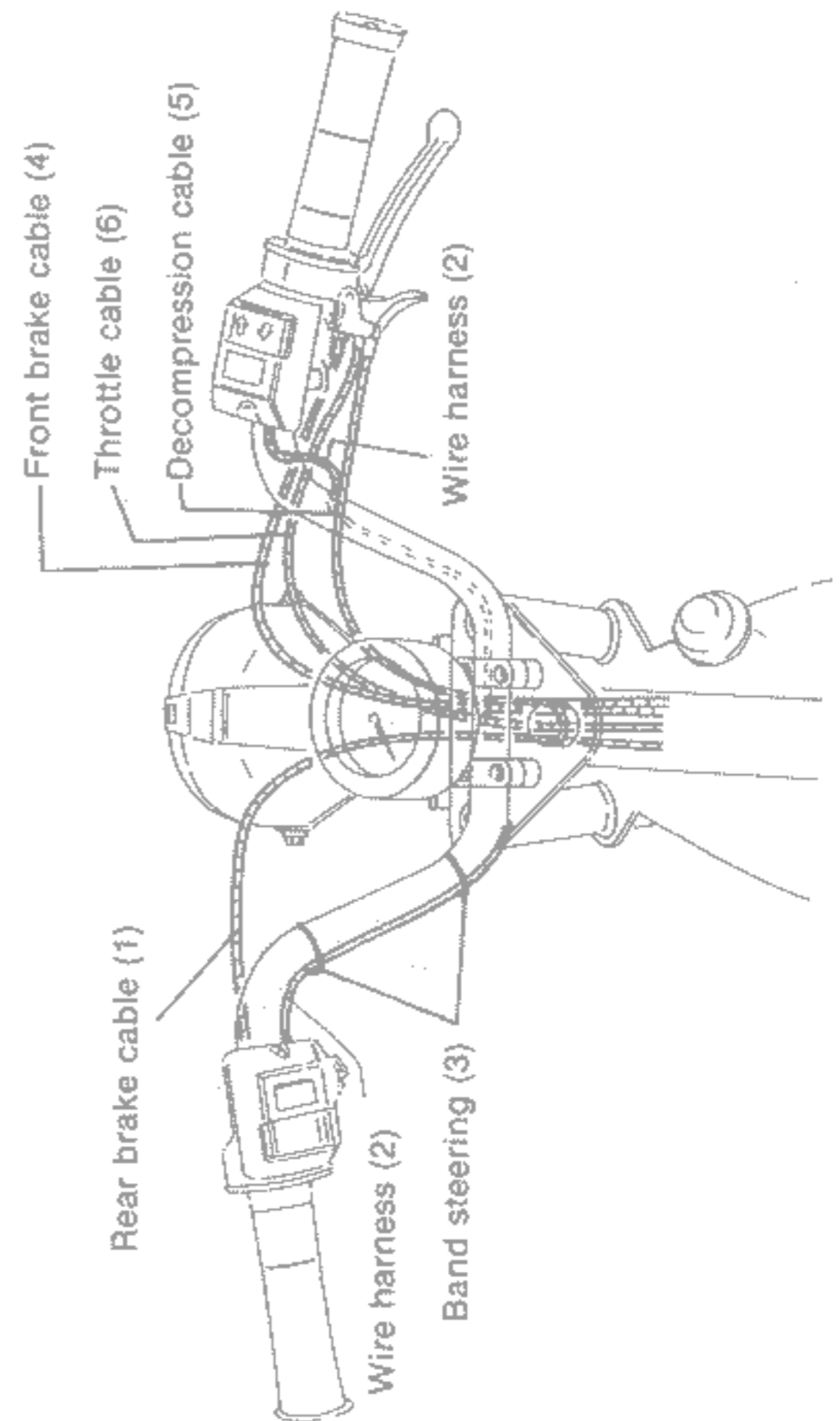
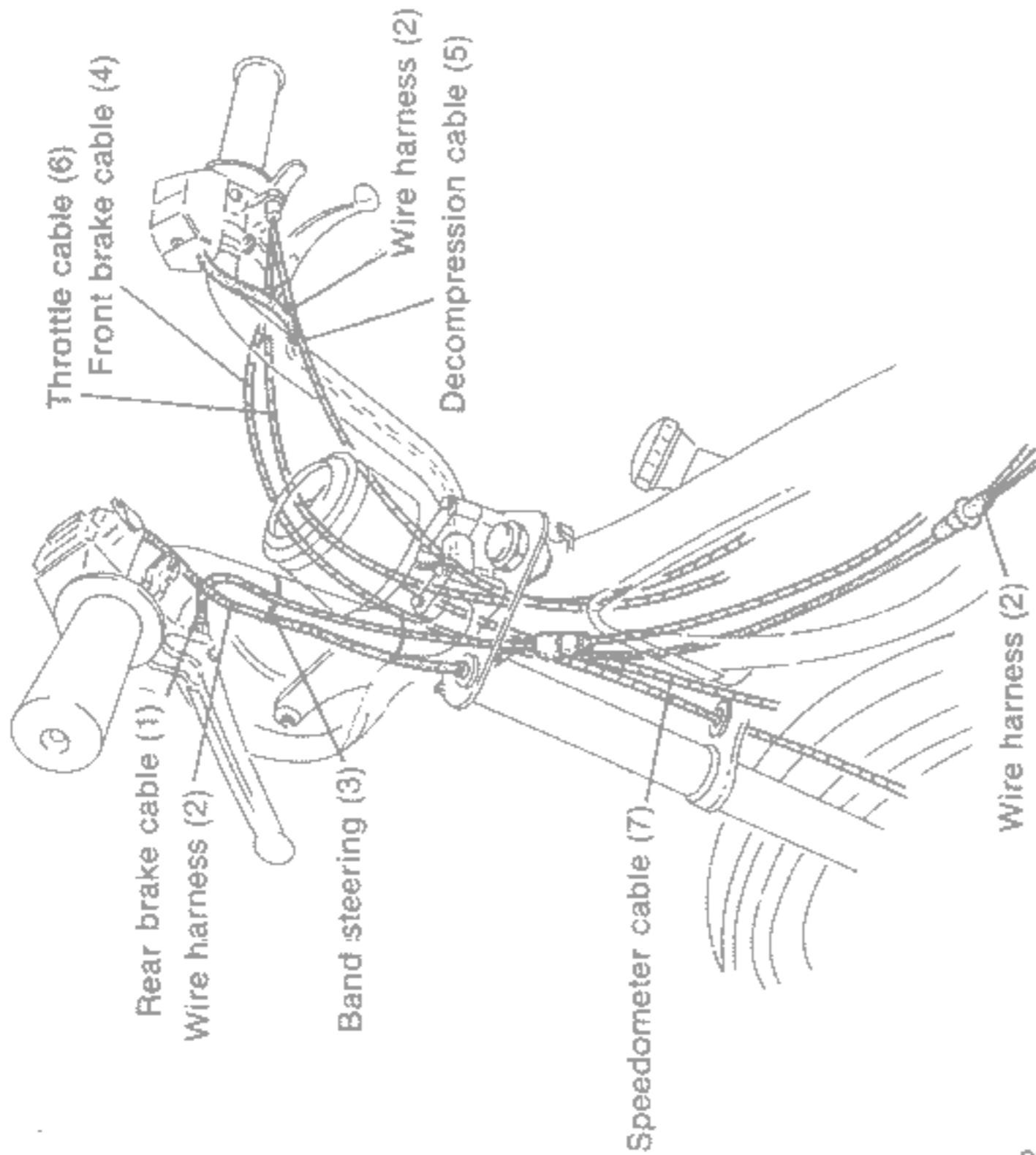
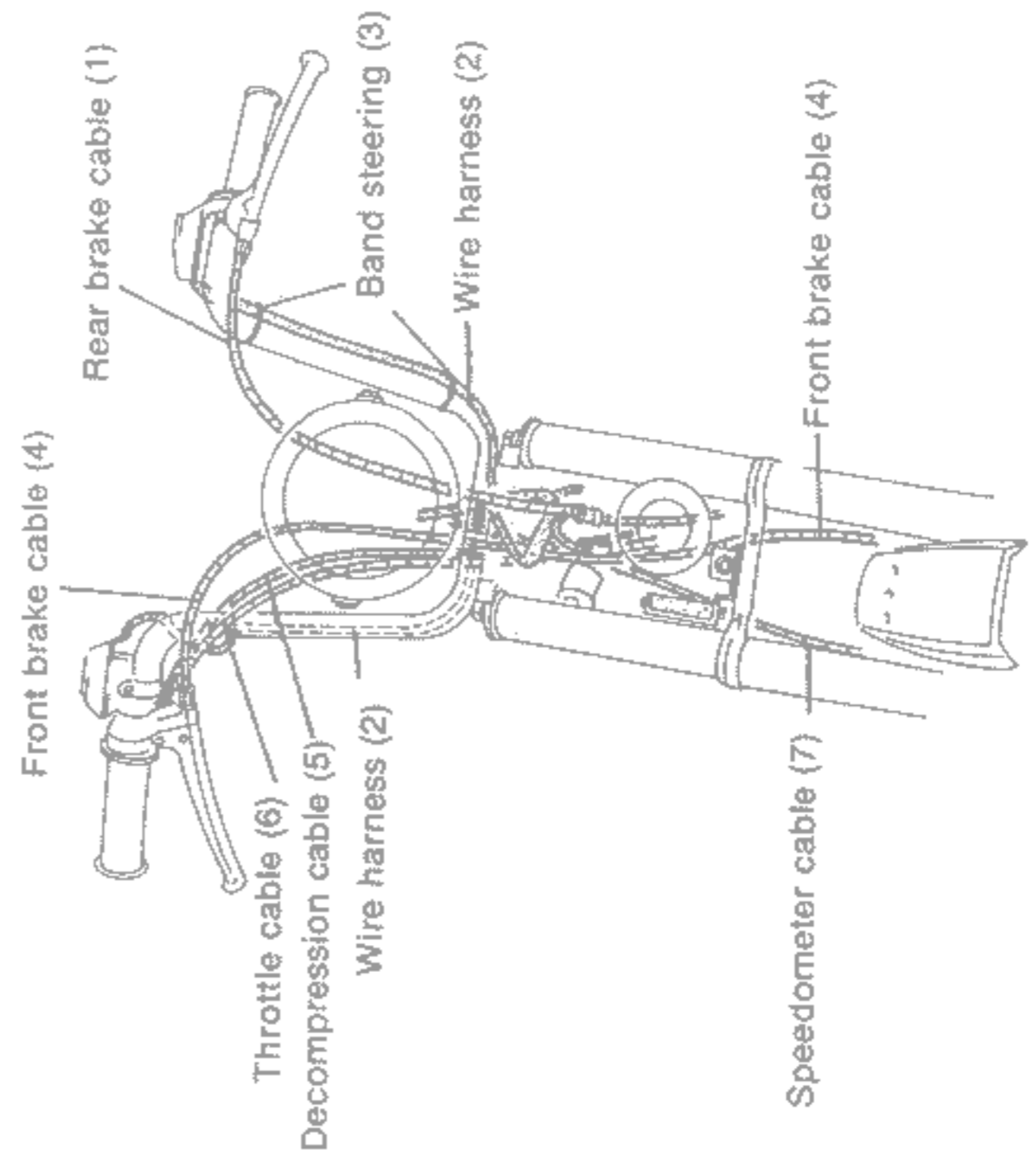
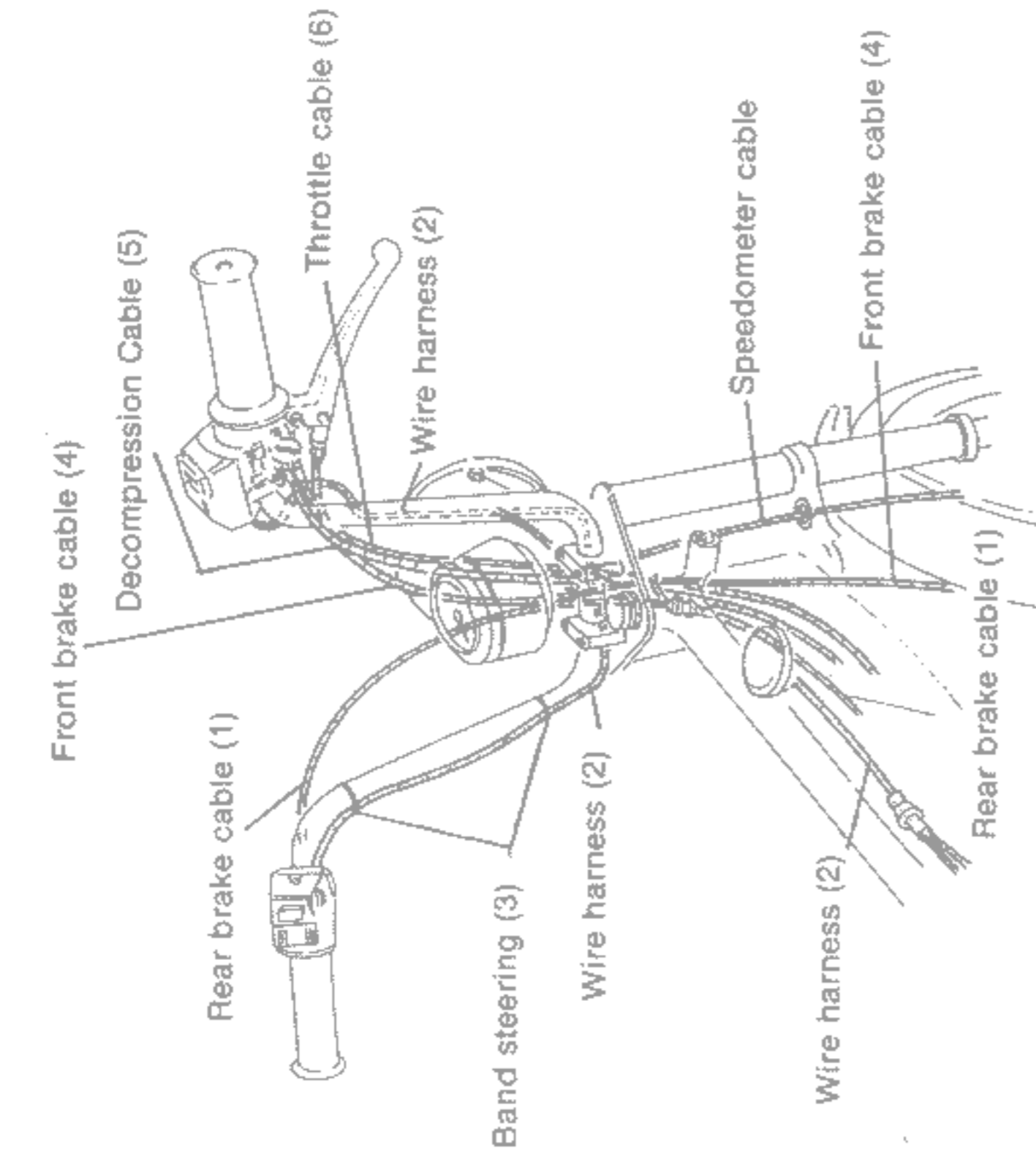



# HONDA PA50

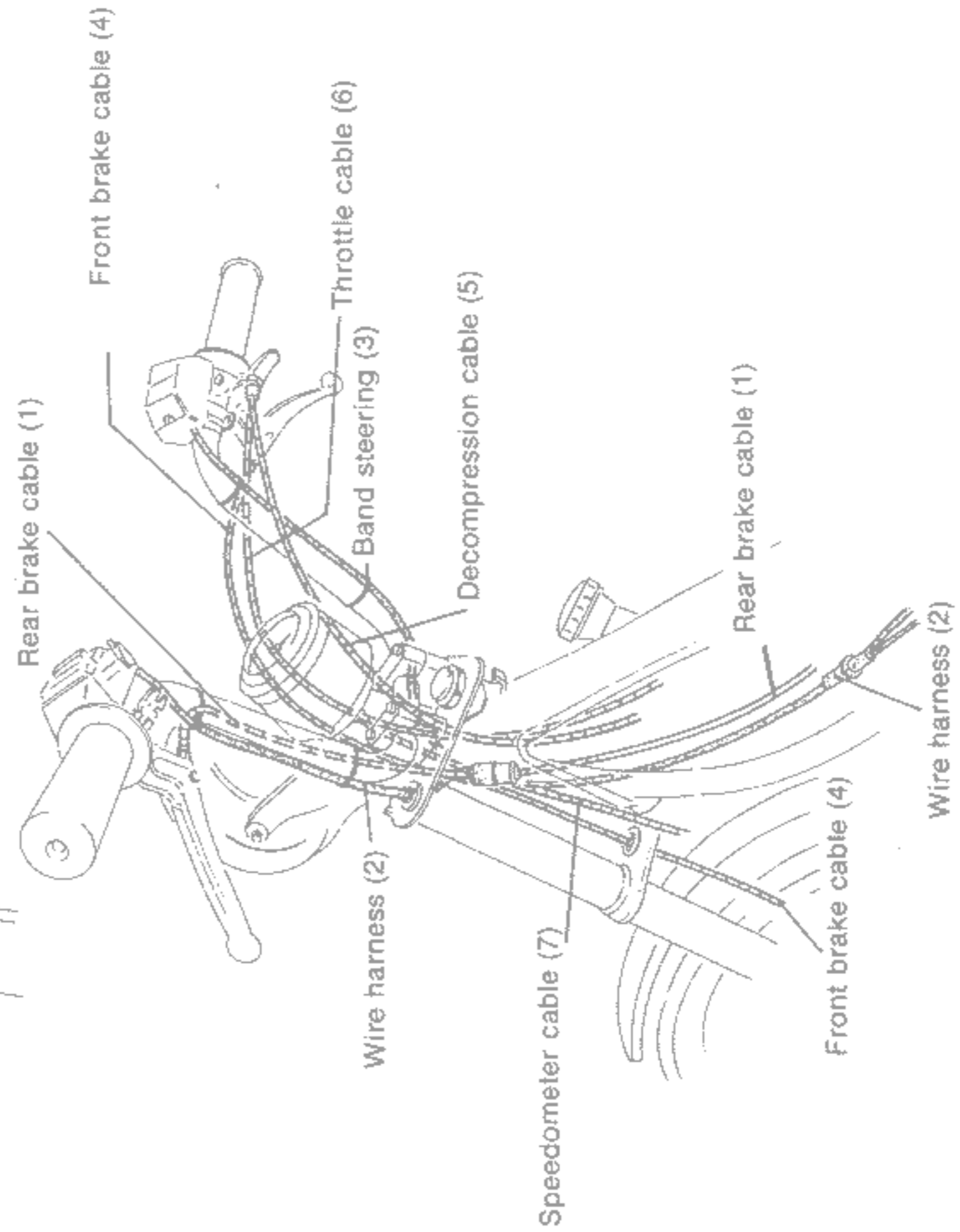
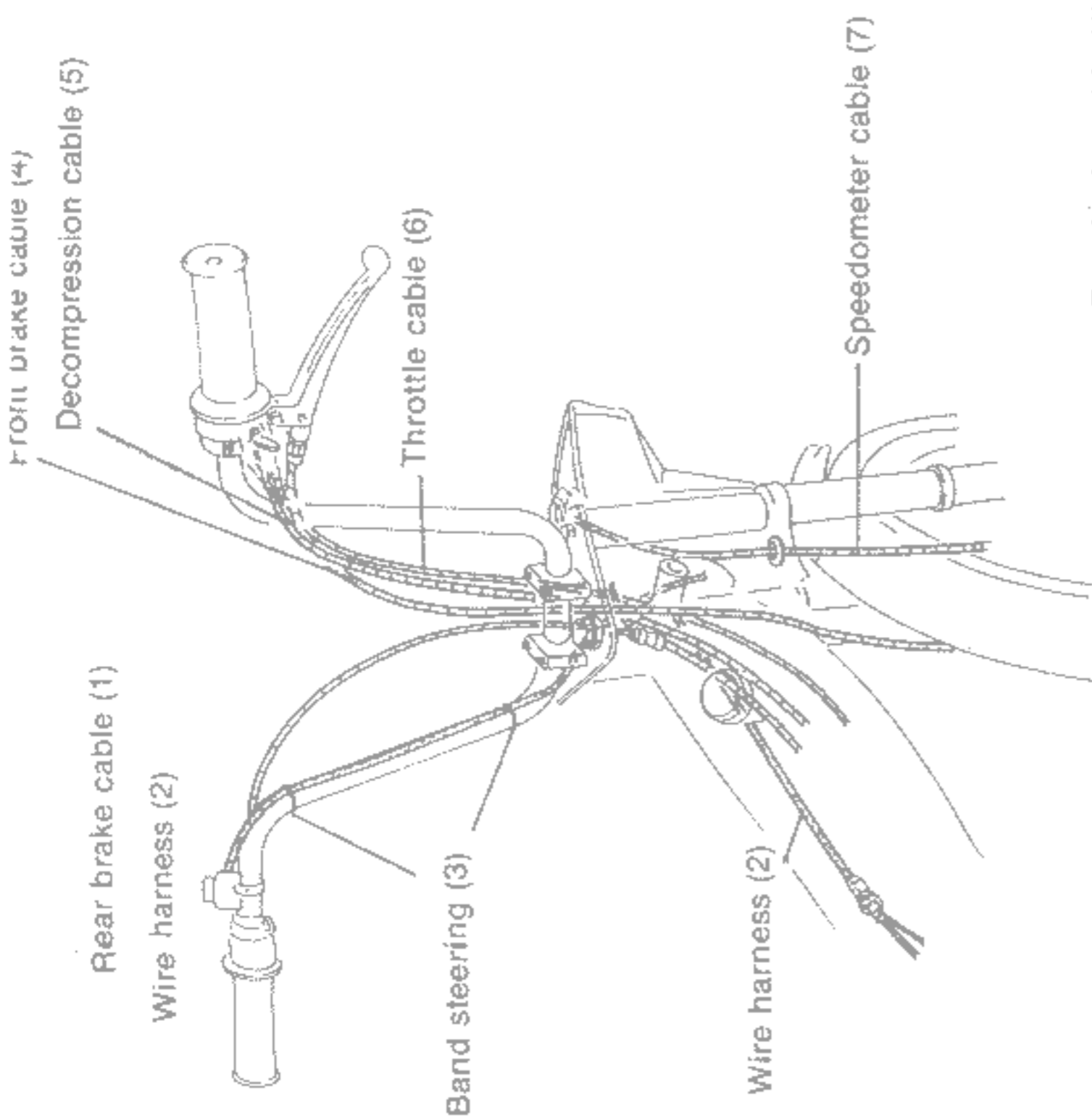
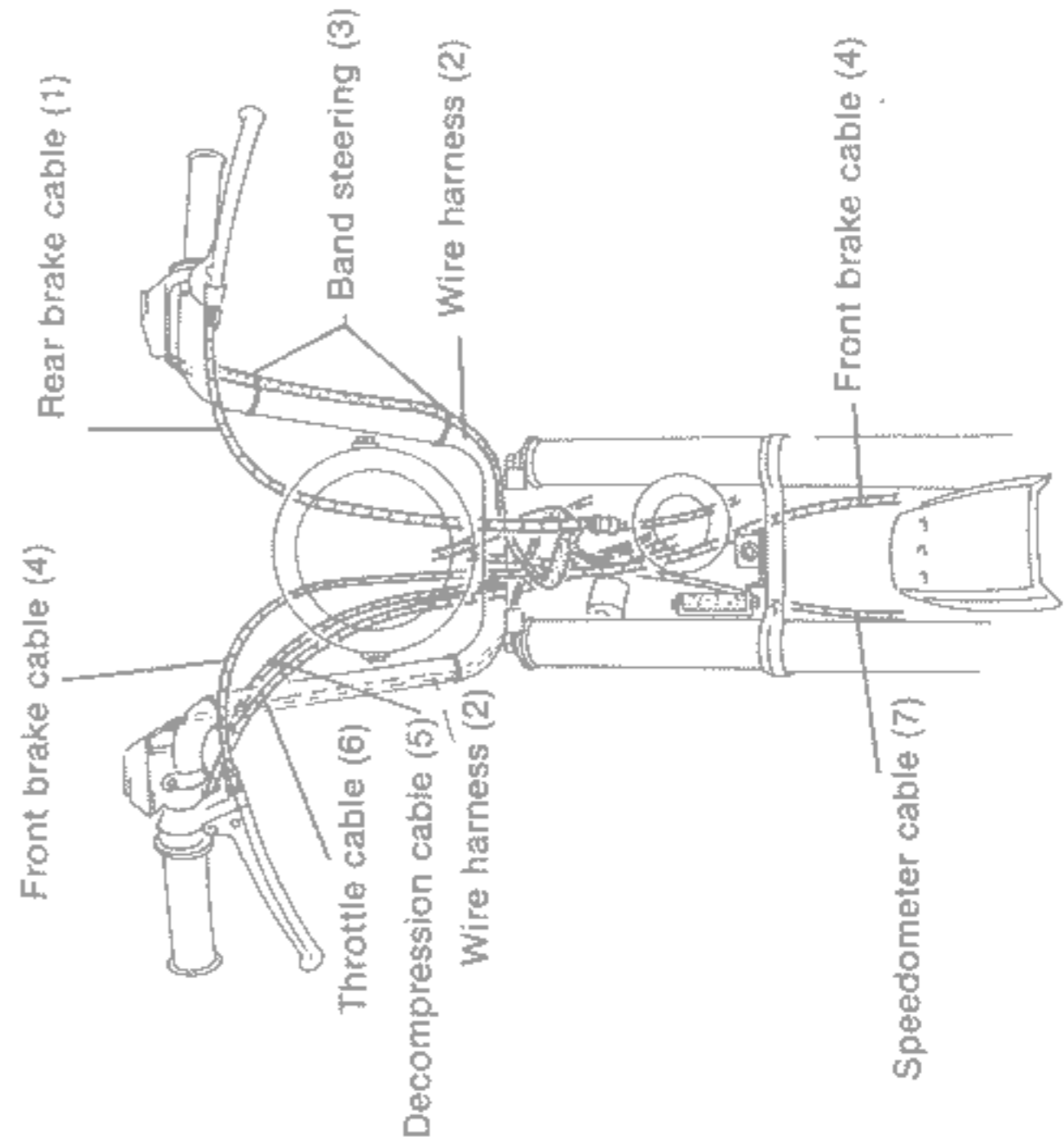
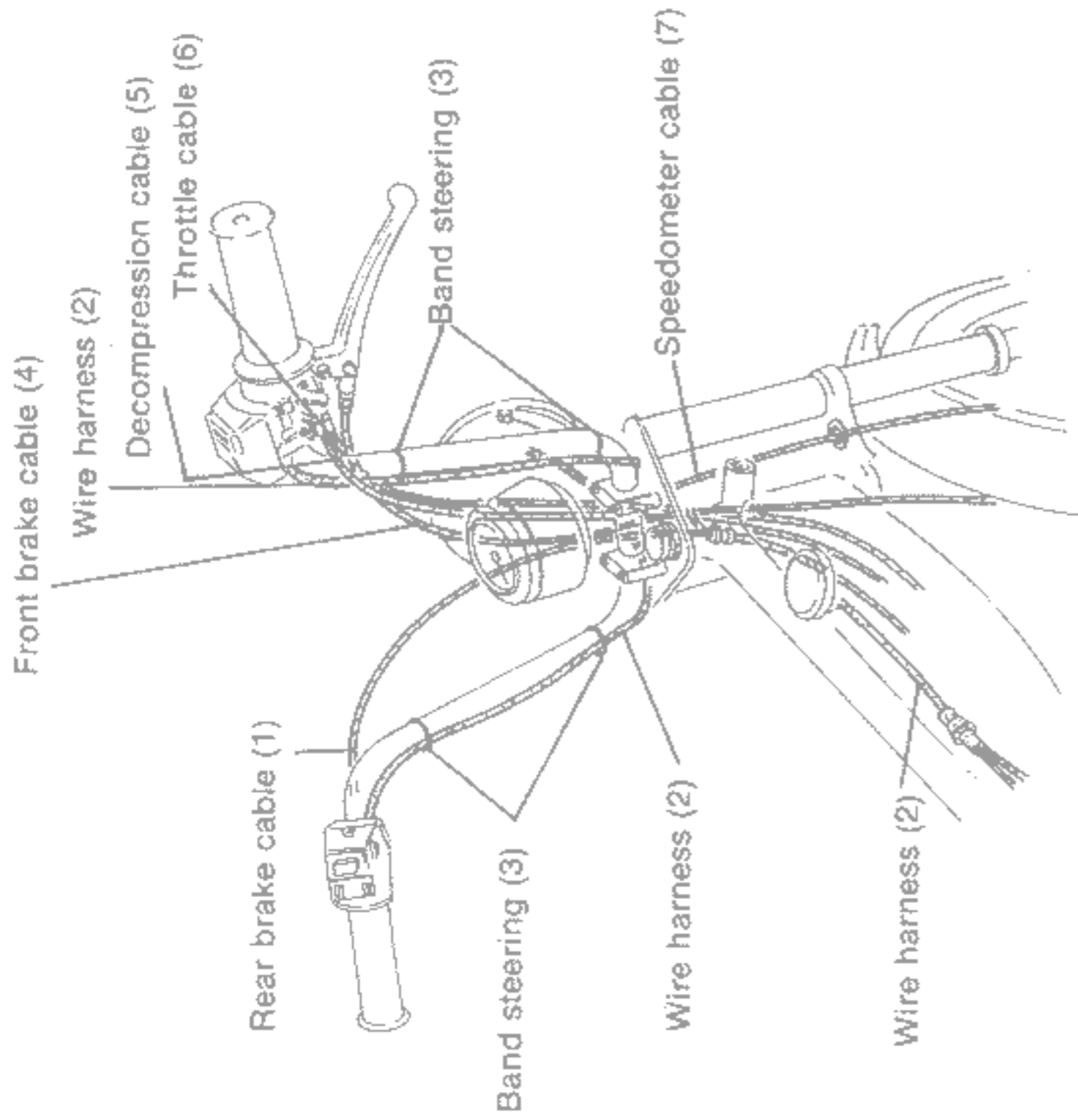



# HONDA PA50

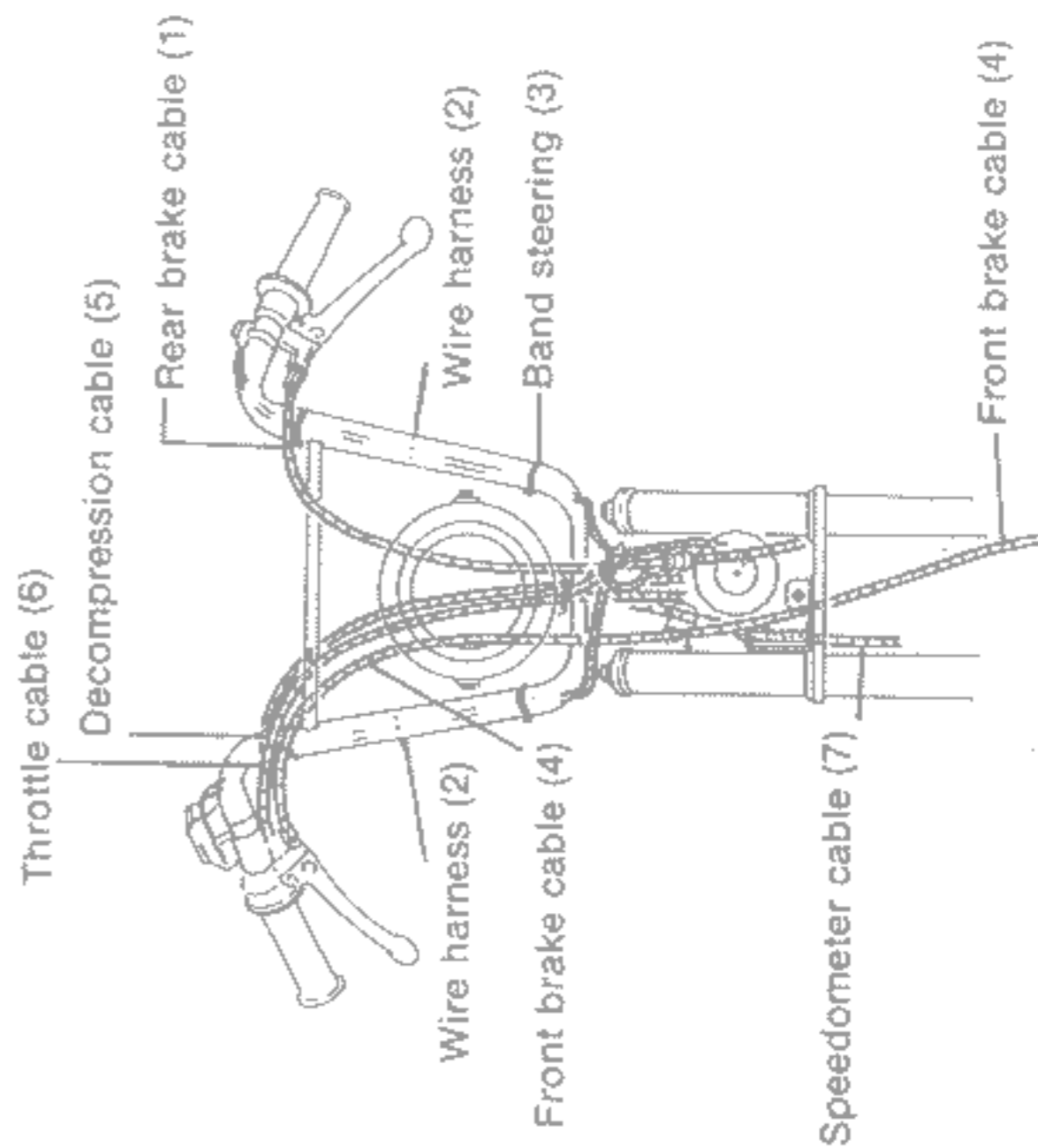
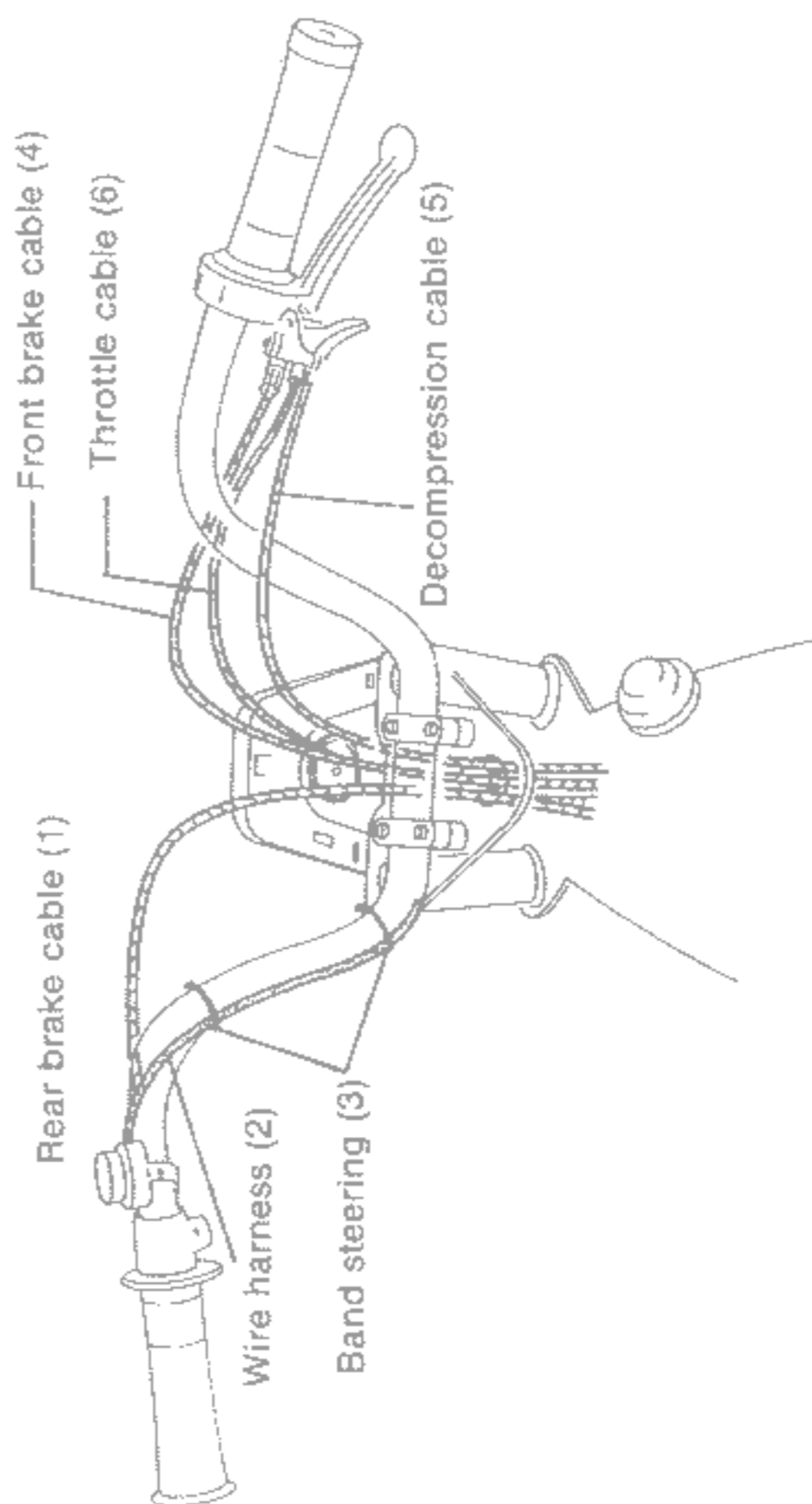
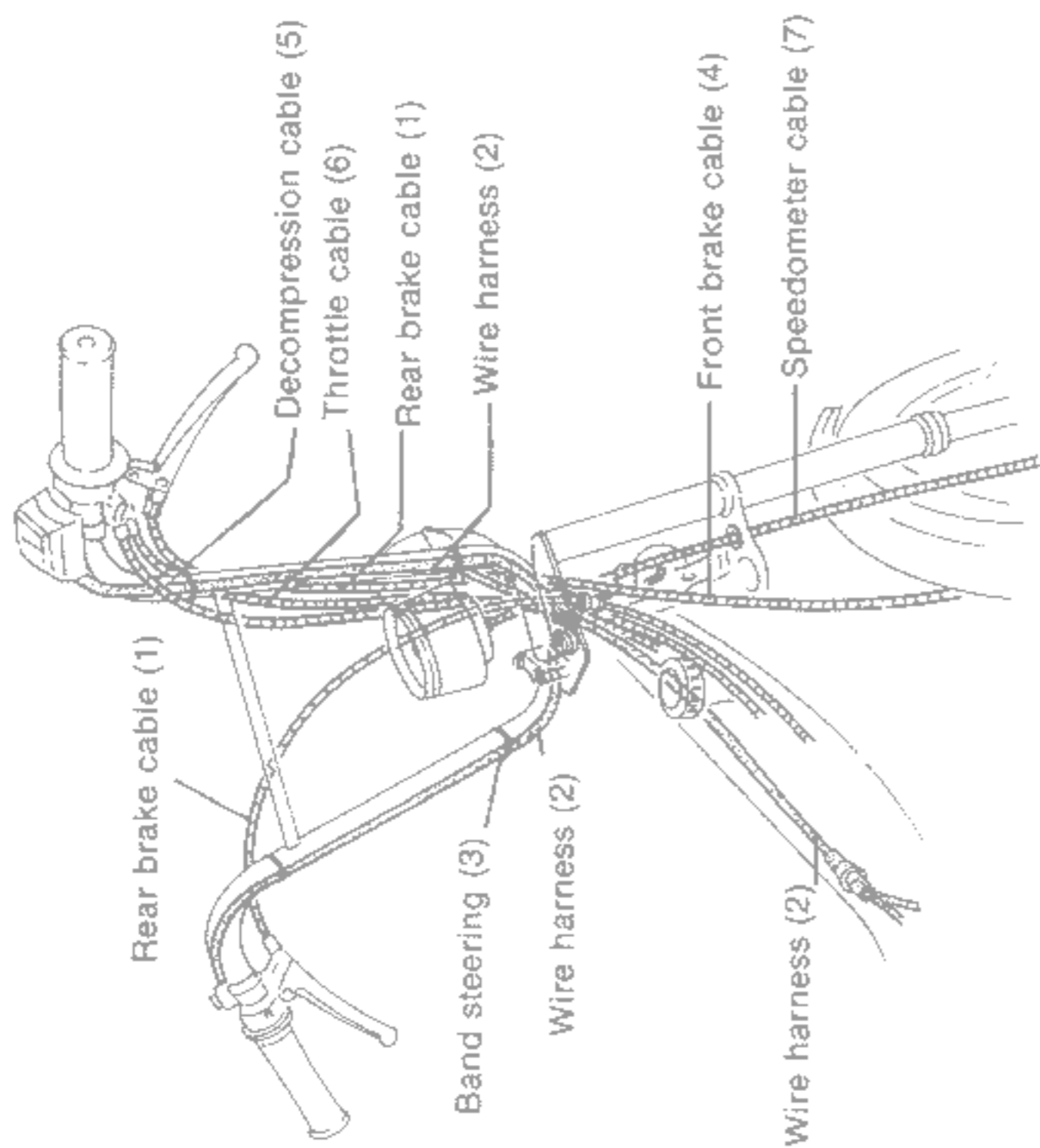
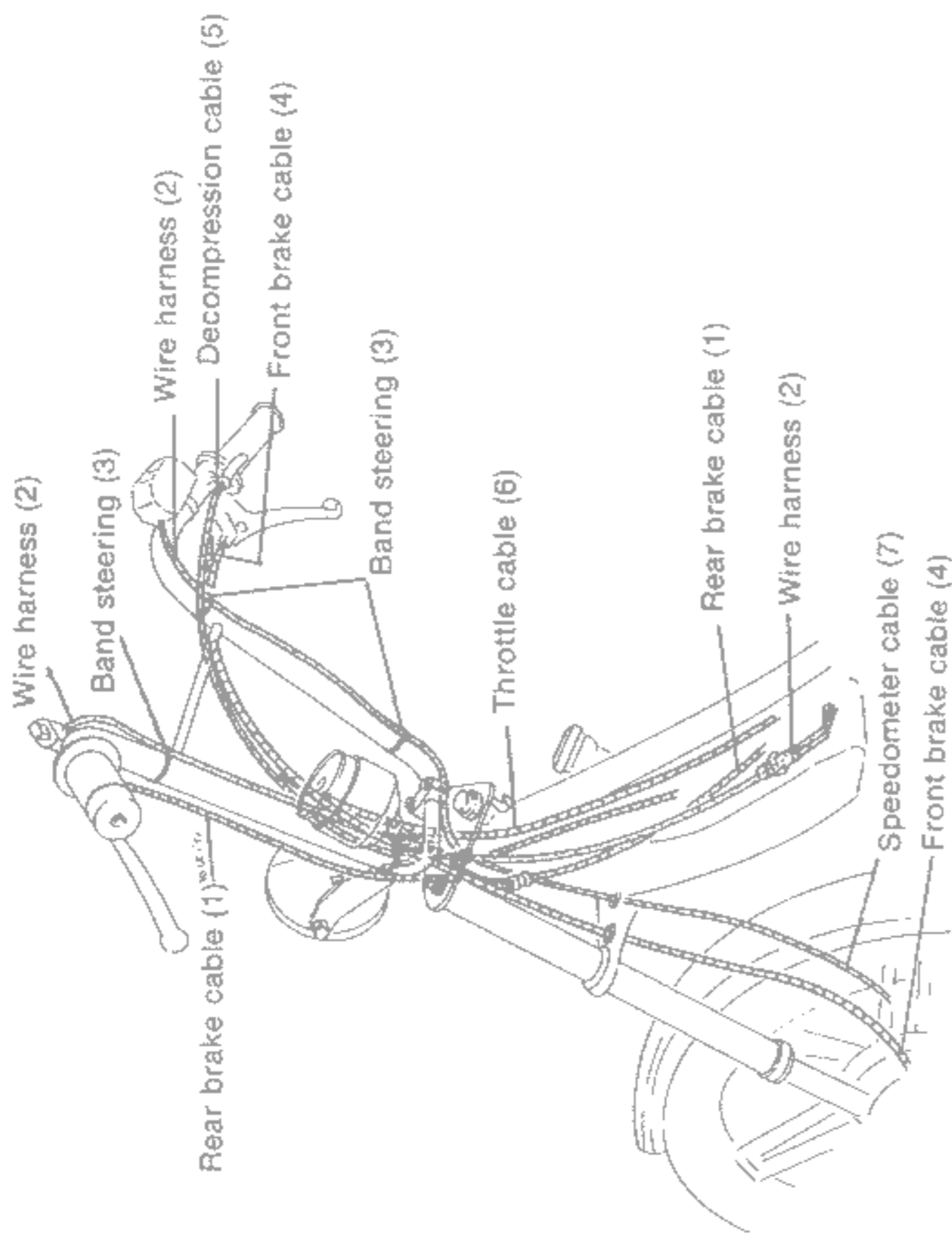



# HONDA PA50

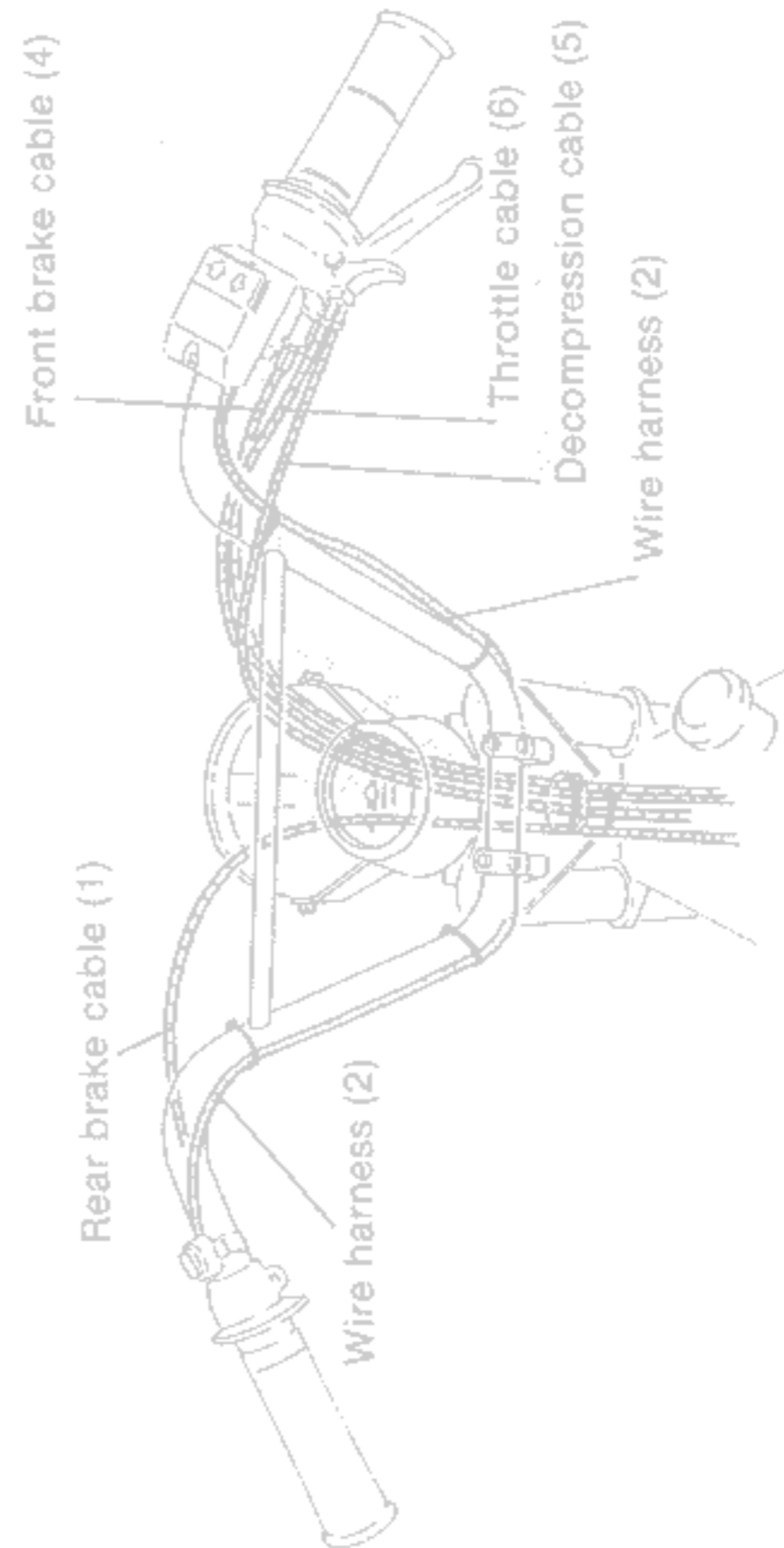
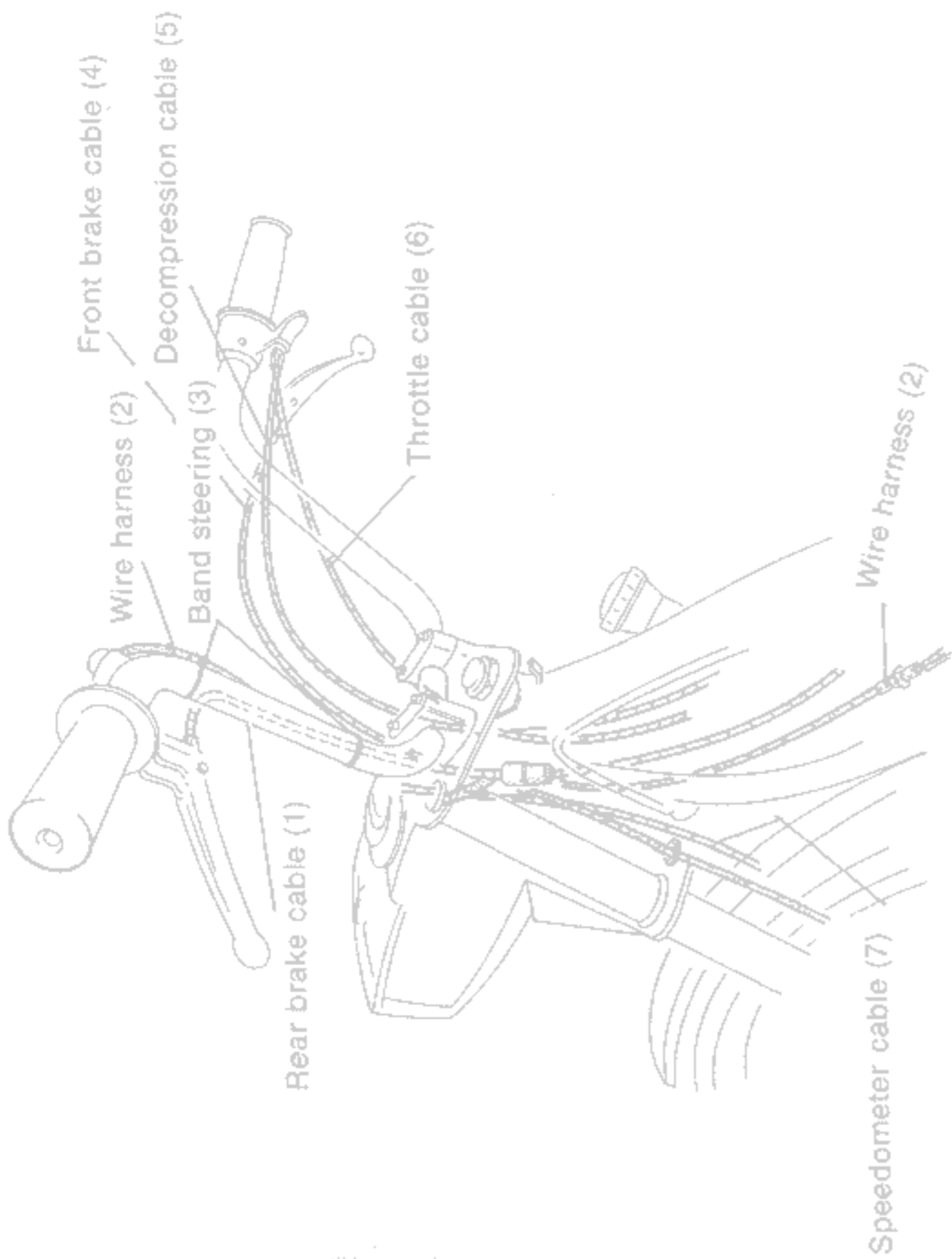
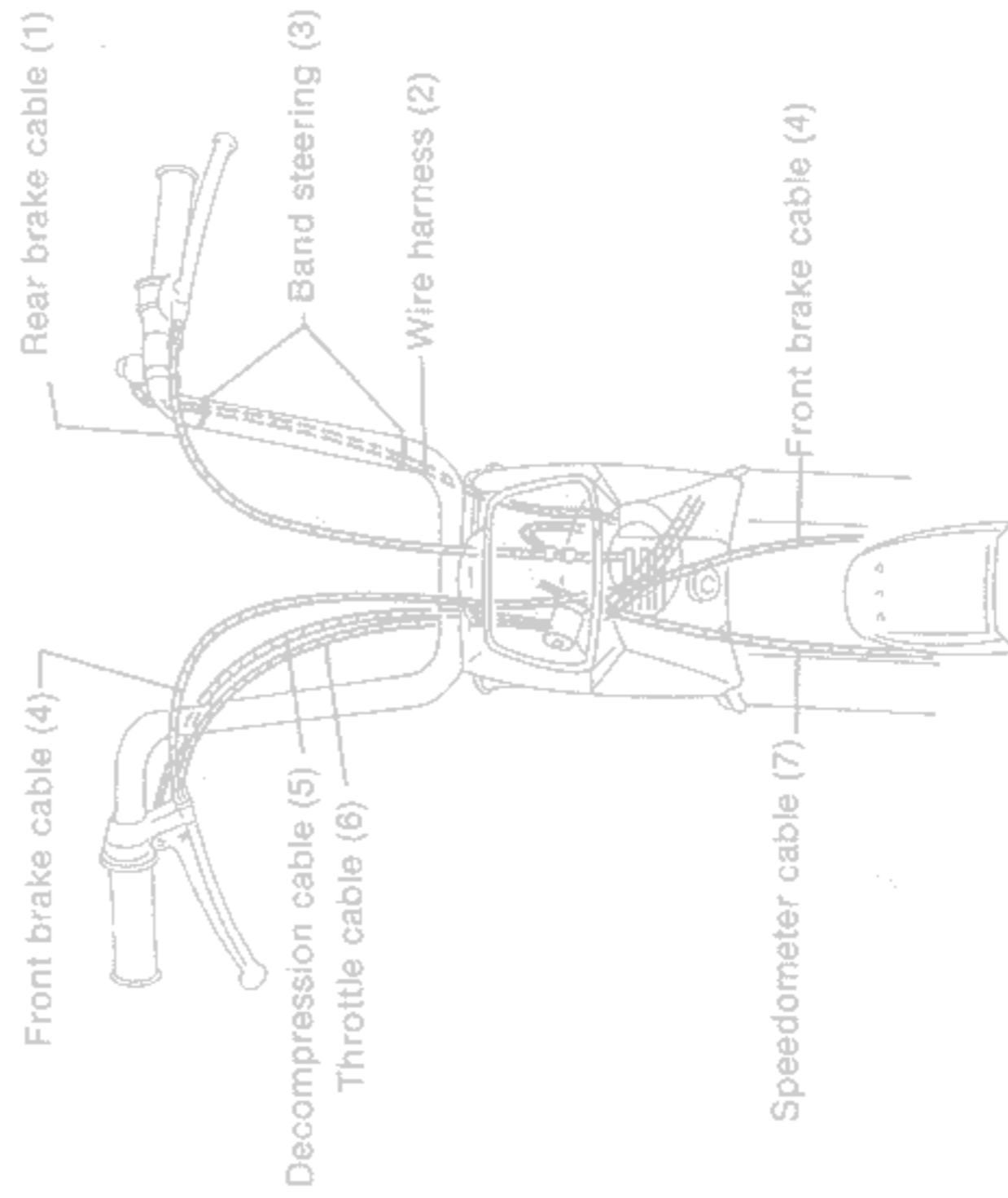
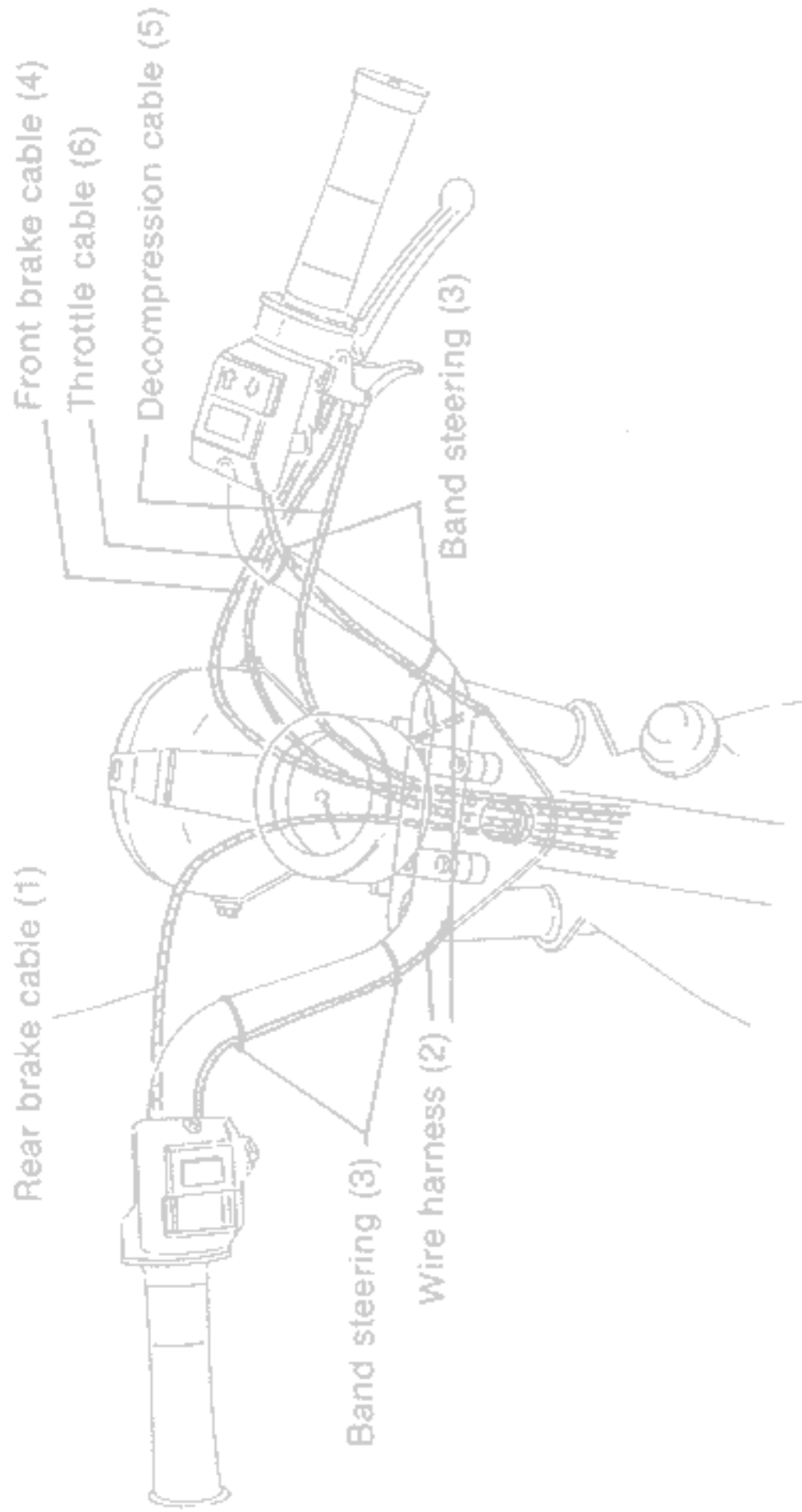





**HONDA<sup>®</sup>**  
**PA50**

---

## MEMO

**MEMO**