

SUZUKI

FZ50

SUPPLEMENTARY SERVICE MANUAL

99000-85057-0E3
(英) SUPPL.

FOREWORD

The FZ50 "T" model was introduced as a new model in 1980. Many innovative refinements were incorporated in the new model. The 1981 FZ50 "X" model utilizes the same technical innovations that were introduced on the "T" model. This supplementary service manual has been produced to aid Suzuki mechanics in properly maintaining and repairing both the 1980 "T" and 1981 "X" models.

This manual has been written primarily for the experienced Suzuki mechanic but will also be very useful even for the amateur, do-it-yourself mechanic. The entire manual should be thoroughly reviewed before any servicing is performed.

Please also refer to the FZ50 "N" MODEL (1979 MODEL) Service Manual for all other areas of information not covered in this publication.

SUZUKI MOTOR CO., LTD.

Service Department
Overseas Operations Division

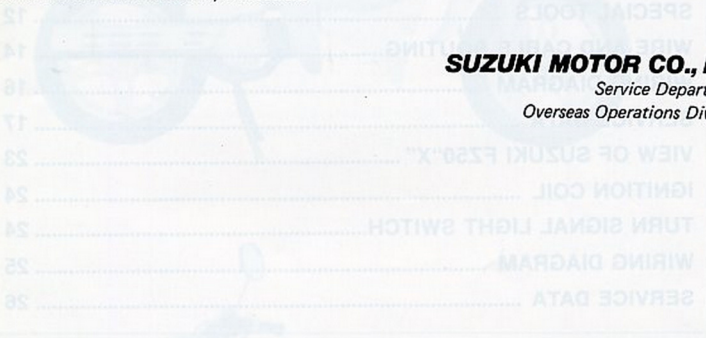

12	SPECIAL TOOLS
13	INDEX
14	WIRING
18	CHASSIS ELECTRICAL
19	VIEW OF SUZUKI FZ50 "X"
23	IGNITION COIL
24	TURN SIGNAL LIGHT SWITCH
25	WIRING DIAGRAM
28	SERVICE DATA

CONTENTS

VIEW OF SUZUKI FZ50“T”	2
SPECIFICATIONS	3
TRANSMISSION OIL	5
“PEI” SYSTEM	6
FLYWHEEL MAGNETO	7
CHASSIS ELECTRICAL	8
SPECIAL MATERIALS	11
SPECIAL TOOLS	12
WIRE AND CABLE ROUTING.....	14
WIRING DIAGRAM	16
SERVICE DATA	17
VIEW OF SUZUKI FZ50“X”	23
IGNITION COIL	24
TURN SIGNAL LIGHT SWITCH.....	24
WIRING DIAGRAM	25
SERVICE DATA	26

SPECIFICATIONS

DIMENSIONS AND WEIGHT

Overall length
Overall width
Overall height
Wheelbase
Ground clearance
Dry mass (weight)

ENGINE

Type
Cylinder
Stroke
Compression ratio
Cooling system
Ignition system
Lubrication system

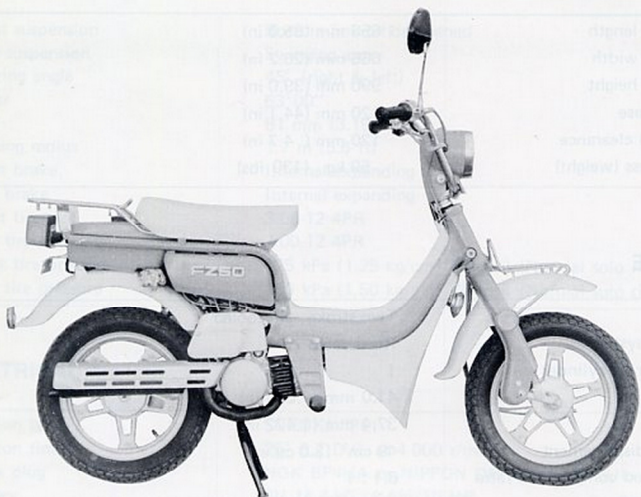

CAPACITIES

TRANSMISSION

Gearbox
Transmission
Gear ratio
Final reduction
Gear ratio
Drive chain



SPECIFICATIONS

DIMENSIONS AND WEIGHT

Overall length	1 650 mm (65.0 in)
Overall width	665 mm (26.2 in)
Overall height	990 mm (39.0 in)
Wheelbase	1 120 mm (44.1 in)
Ground clearance	120 mm (4.7 in)
Dry mass (weight)	59 kg (130 lbs)

ENGINE

Type	Two-stroke, air cooled
Intake system	Reed valve
Number of cylinder	1
Bore	41.0 mm (1.614 in)
Stroke	37.4 mm (1.472 in)
Piston displacement	49 cm ³ (3.0 cu.in)
Corrected compression ratio	6.1 : 1
Carburetor	MIKUNI VM14SH, single
Air cleaner	Polyurethane foam element
Starter system	Primary kick
Lubrication system	SUZUKI "CCI"

TRANSMISSION

Clutch	Wet shoe, automatic, centrifugal type
Transmission	2-speed
Gearshift pattern	Automatic type
Primary reduction	1.000
Final reduction	8.696
(chain)	2.384 (31/13)
(gear)	3.647 (62/17)
Gear ratios, Low	2.137 (62/29)
2nd	1.421 (54/38)
Drive chain	DAIDO D.I.D. 270H, 64 links

CHASSIS

Front suspension	Bottom link oil damped
Rear suspension	Swinging arm
Steering angle	45° (right & left)
Caster	63°00''
Trail	81 mm (3.19 in)
Turning radius	1.7 m (5.6 ft)
Front brake	Internal expanding
Rear brake	Internal expanding
Front tire size	3.00-12 4PR
Rear tire size	3.00-12 4PR
Front tire pressure	125 kPa (1.25 kg/cm ² , 18 psi) (Normal solo riding)
Rear tire pressure	150 kPa (1.50 kg/cm ² , 21 psi) (Normal solo riding)

ELECTRICAL

Ignition type	SUZUKI "PEI"
Ignition timing	25° B.T.D.C. at 4 000 r/min
Spark plug	NGK BP4HA or NIPPON DENSO W14FP-UL
Battery	6V 14.4 kC (4 Ah)/10 HR
Generator	Flywheel magneto
Fuse	10A

CAPACITIES

Fuel tank including reserve reserve	4.5 L (1.2 US gal) 0.2 L (0.2 US qt)
Engine oil tank	1.2 L (1.27 US qt)
Transmission oil	800 ml (0.85 US qt)

* These specifications are subject to change without notice.

TRANSMISSION OIL

Use a good quality SAE 20W/40 multi-grade motor oil.

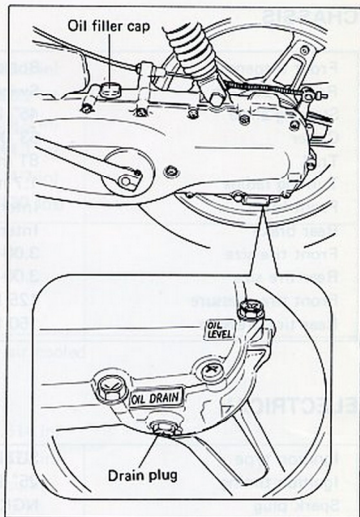

TRANSMISSION		Capacity
Clutch	0.3 L (0.8 US qt)	Engine oil tank
Transmission	1.3 L (1.3 US qt)	Transmission oil
Gearshift pattern	5-speed	
Primary reduction	0.011	
Final reduction	0.008	
	0.113 (48.2)	
	0.129 (56.2)	
Gear ratios: Low	0.028 (12.1)	
2nd	0.047 (14.9)	
Drive chain	0.010 (0.413)	

* These specifications are subject to change without notice.

"PEI" SYSTEM

In the FZ50 ignition system, the PEI system is used.

The PEI system uses a magneto as the power source, and the capacitor (condenser) momentarily stores a charge up to hundreds of volts.

The charge is instantly discharged, at the specified ignition timing, to the ignition coil primary winding, thus inducing a high surge of voltage in the secondary winding. As a result, a spark occurs at the spark plug gap.

The PEI magneto has no breaker points and therefore it is free from mechanical trouble. This ensures a stabler secondary high voltage and better spark performance.

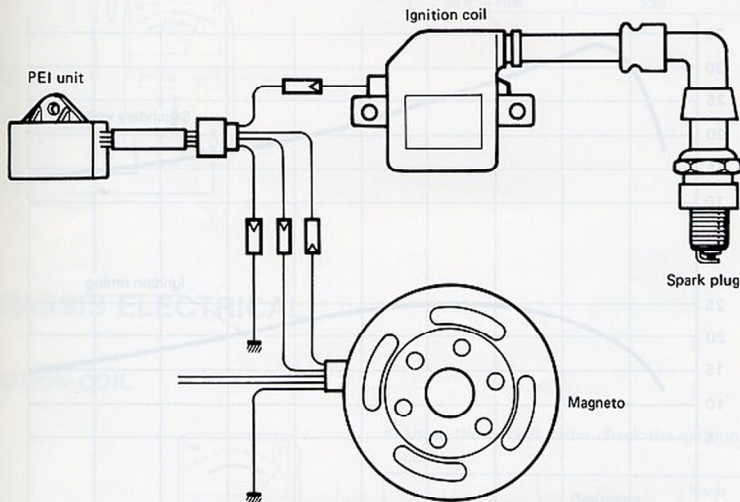

CONNECTING DIAGRAM

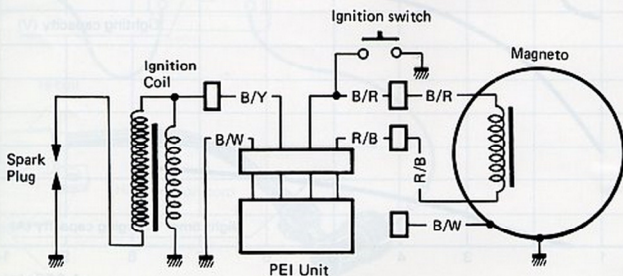

FLYWHEEL MAGNETO

SPECIFICATIONS

- Ignition method:
- Light capacity:
- Charging capacity:
- Secondary voltage:
- Ignition coil resistance:

2 sparks per crankshaft rotation

5.5 V or more at 2 500 r/min

8.5 V or less at 8 000 r/min

0.7 A or more at 4 000 r/min

3.0 A or less at 8 000 r/min

12 kV or more at 500 – 8 000 r/min

Primary Approx. 0 – 1 Ω

Secondary Approx. 15 – 17 k Ω

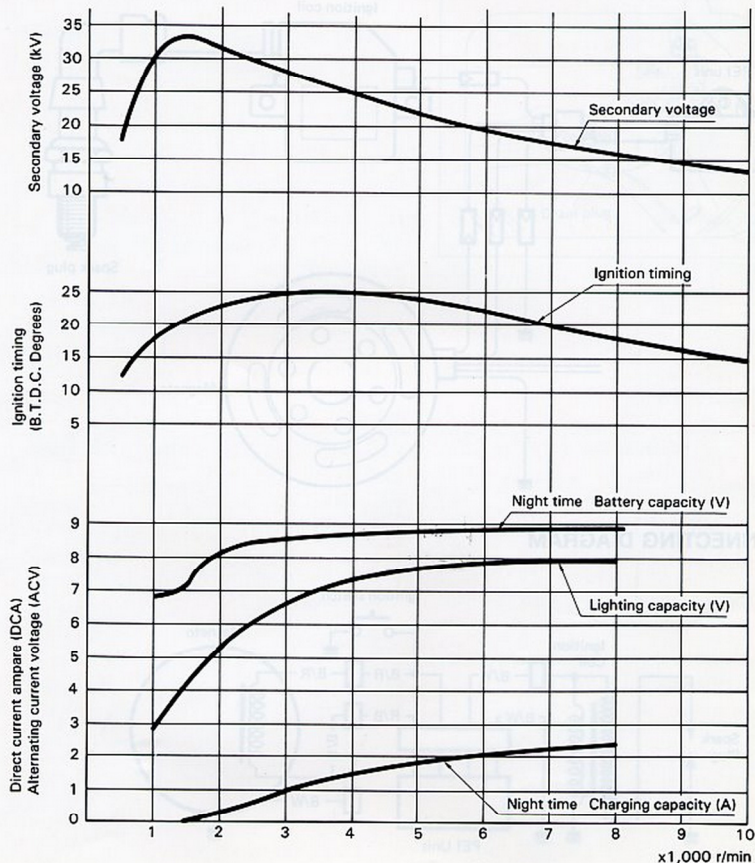

STATOR

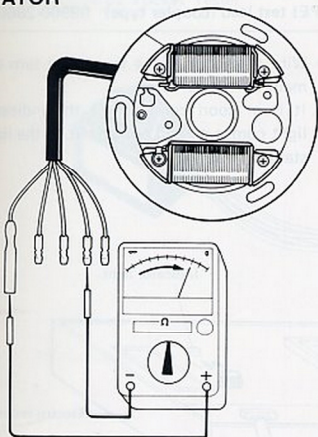

Pocket tester

09900-25002

- Select the knob to RX "x 1".
- Make a following continuity test.

Unit : Approx. (Ω)

COLOR CODE	APPROX. (Ω)
B/W - Y	0.4
B/W - W/R	0.75
B/R - R/B	230

CHASSIS ELECTRICAL

IGNITION COIL

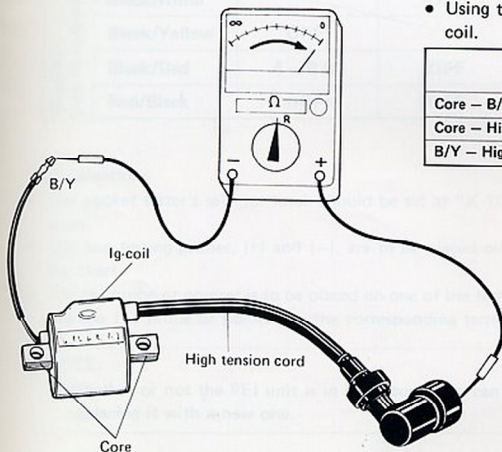

- Using the pocket tester check the ignition coil.

	Resistance	Knob position
Core - B/Y	0 - 1 Ω	x 1 Ω
Core - High tension	Approx. 15-17 k Ω	x k Ω
B/Y - High tension	Approx. 15-17 k Ω	x k Ω

"PEI" UNIT

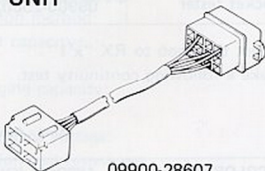

09900-28607

PEI test lead (coupler type)	09900-28607
------------------------------	-------------

- Wire as shown in the figure and turn the main switch to ON.
- It is in good condition if the indicator light comes on and remains lit. If the light stays off, replace it.

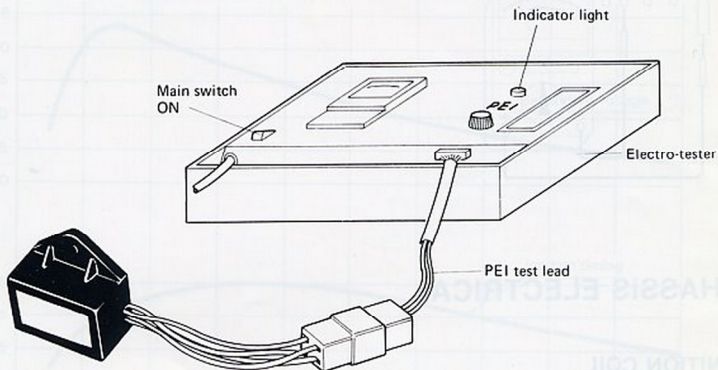

PEI Inspection by Pocket Tester

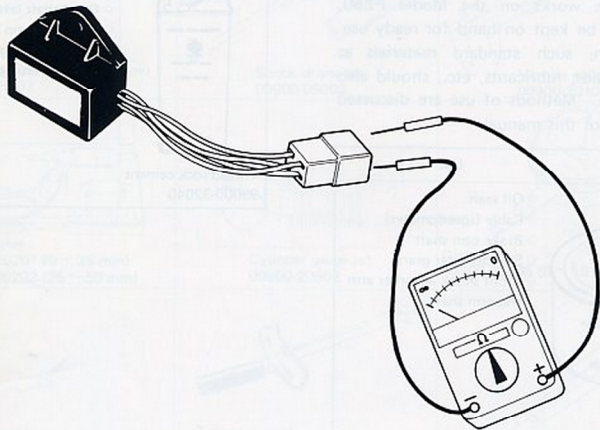

		Positive (+) pointer to touch:			
		Black/White	Black/Yellow	Black/Red	Red/Black
Negative (-) pointer to touch:	Black/White		OFF	5 – 7 Ω	4 – 6 Ω
	Black/Yellow	OFF		OFF	OFF
	Black/Red	4 – 6 Ω	OFF		OFF
	Red/Black	OFF	OFF	15 – 17 Ω	

Test conditions

- The pocket tester's selector knob should be set at "X 1Ω" or "X 1 kΩ" range referring to the chart.
- The two testing probes, (+) and (-), are to be placed on terminals of the PEI unit referring to the chart.
- The (+) probe or pointer is to be placed on one of the terminals listed in the top horizontal row, and the (-) probe or pointer on the corresponding terminal listed in the vertical column.

NOTE:

- Whether or not the PEI unit is in good condition can be determined easily by temporarily replacing it with a new one.

SPECIAL MATERIALS

MATERIAL REQUIRED FOR MAINTENANCE

The materials listed below are required for maintenance works on the Model FZ50, and should be kept on hand for ready use. In addition, such standard materials as cleaning fluids, lubricants, etc., should also be available. Methods of use are discussed in the text of this manual.

Material	Use
<p>Suzuki super grease "A" 99000-25010</p>	<ul style="list-style-type: none"> ○ Oil seals ○ Cable (speedometer) ○ Brake cam shaft ○ Speedometer gears ○ Front shock absorber arm and arm shaft
<p>Suzuki bond 1215 99104-31110</p>	<ul style="list-style-type: none"> ○ Crankcase mating surface
<p>Suzuki lock super "1363C" 99104-32050</p>	<ul style="list-style-type: none"> ○ Muffler fitting bolt



Thread lock cement
99000-32040

- Screws (securing read valve)
- Crankshaft RH oil seal (to outer surface of oil seal)
- Magneto rotor nut
- Crankshaft left end nut
- Muffler clamp bolt
- Horn adjusting screw
- Cylinder stud bolts

SPECIAL TOOLS ROUTING



Snap ring pliers (opening type)
09900-06107

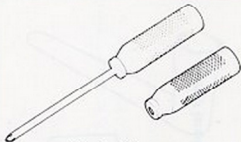

Shock driver set
09900-09002



Vernier calipers
09900-20101

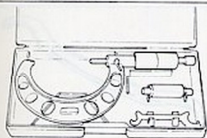

Micrometer
09900-20201 (0 ~ 25 mm)
09900-20202 (25 ~ 50 mm)

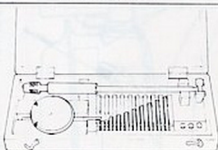

Cylinder gauge set
09900-20508



Dial gauge
09900-20606 (0 ~ 10 mm, $\frac{1}{100}$ mm)



Thickness gauge
09900-20803



Torque wrench
09009-21102 (0 ~ 120 kg-cm)
09900-21103 (100 ~ 900 kg-cm)

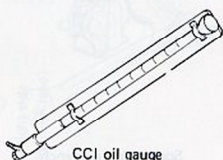

CCI oil gauge
09900-21602



Pocket tester
09900-25002



Electro-tester
09900-28106

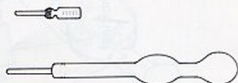

Hydrometer
09900-28403

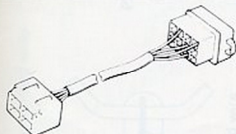

PEI test lead
09900-28607

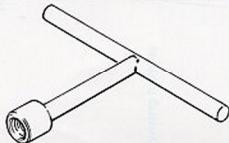

Stud bolt installer
09910-10110

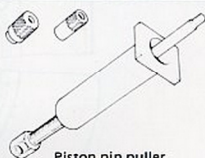

Piston pin puller
09910-34510

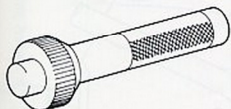



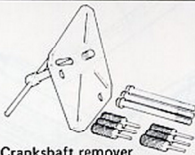



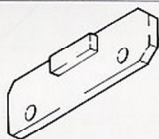

Bearing installer
09913-75820

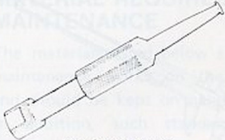

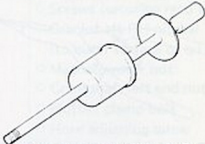
Crankshaft remover
09920-13111

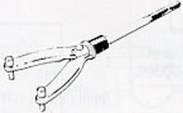
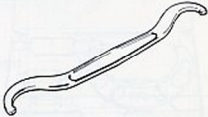
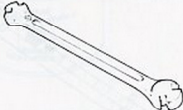

Clutch holder
09920-30220

 <p>Bearing remover 09921-20210</p>	 <p>Spark plug wrench 09930-10111</p>	 <p>Rotor remover slide shaft 09930-30102</p>
 <p>Attachment C (27 mm screw) 09930-30161</p>	 <p>Rotor holder 09930-40113</p>	 <p>Steering stem nut wrench 09940-10122</p>
 <p>Spoke nipple wrench 09940-60113</p>	 <p>Steering race installer 09940-53111</p>	 <p>Steering race and swing arm bearing installer 09941-34511</p>
 <p>Tire pressure gauge 96200-41330</p>		

WIRE AND CABLE ROUTING

WIRE ROUTING

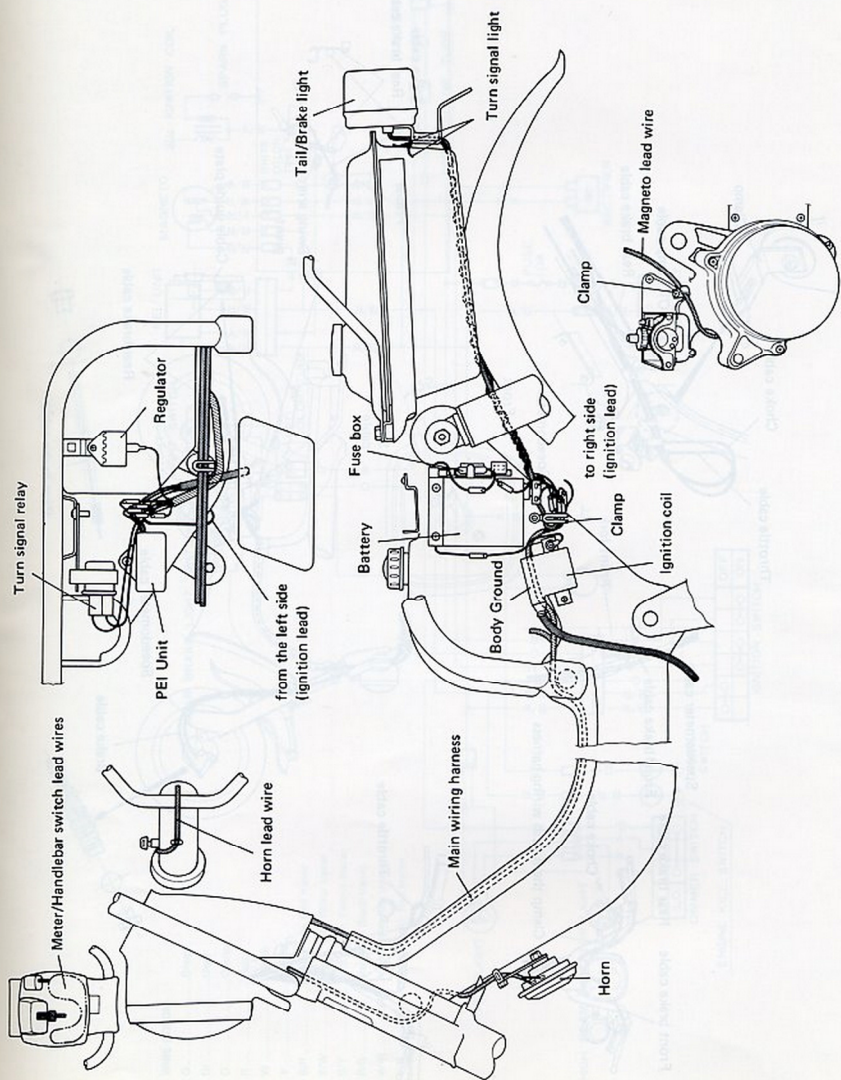

CABLE ROUTING

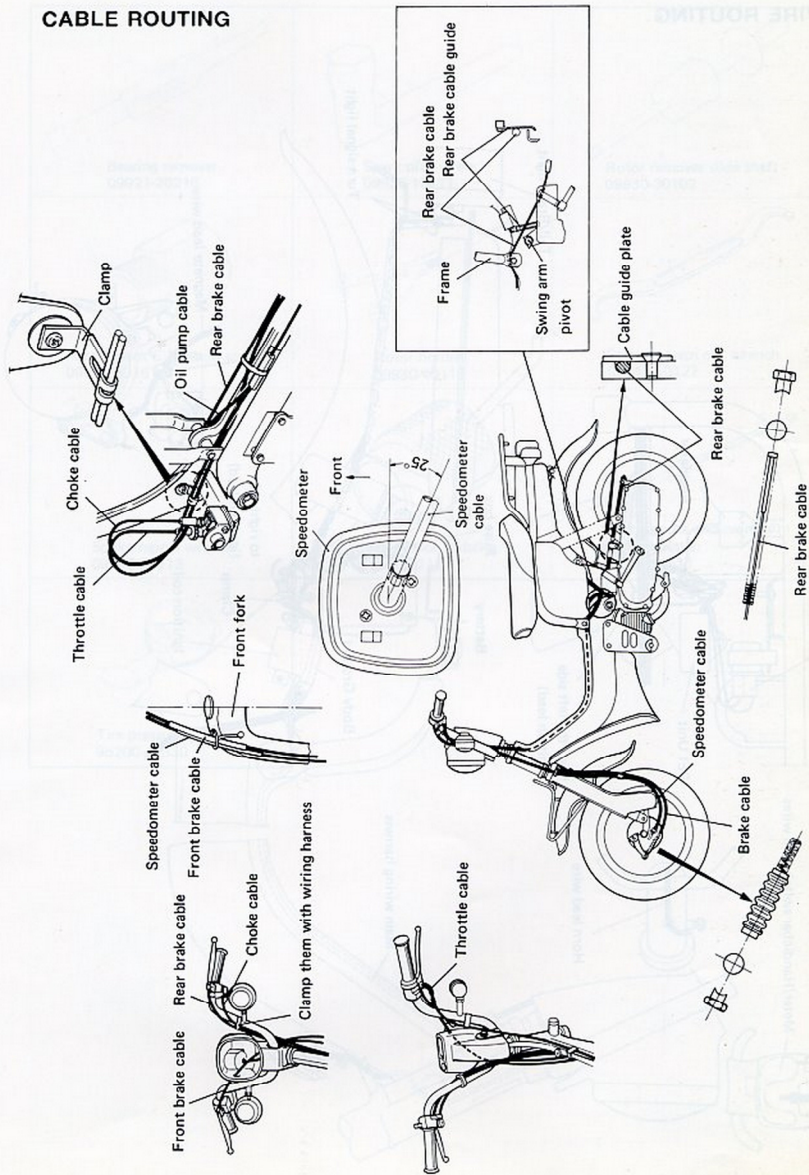

WIRING DIAGRAM

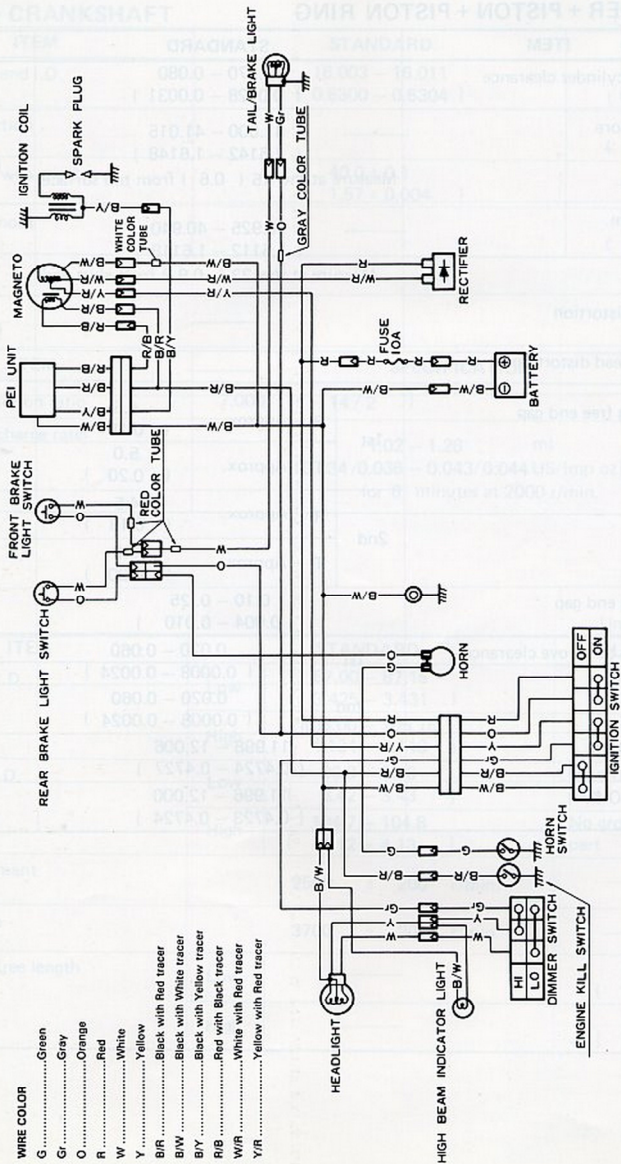

SERVICE DATA

WIRING DIAGRAM

CYLINDER + PISTON + PISTON RING

Unit: mm (in)

ITEM	STANDARD		LIMIT
Piston to cylinder clearance	0.070 – 0.080 (0.0028 – 0.0031)		0.120 (0.0047)
Cylinder bore	41.000 – 41.015 (1.6142 – 1.6148) Measure at the 15 (0.6) from top surface.		41.060 (1.6165)
Piston diam.	40.925 – 40.940 (1.6112 – 1.6118) Measure at the 23 (0.9) from skirt end.		40.880 (1.6094)
Cylinder distortion	—		0.05 (0.002)
Cylinder head distortion	—		0.05 (0.002)
Piston ring free end gap	1st	R Approx. 4.5 (0.18)	3.6 (0.14)
		T Approx. 5.0 (0.20)	4.0 (0.16)
	2nd	R Approx. 4.5 (0.18)	3.6 (0.14)
		T Approx. 5.0 (0.20)	4.0 (0.16)
Piston ring end gap	0.10 – 0.25 (0.004 – 0.010)		0.75 (0.030)
Piston ring to groove clearance	1st	0.020 – 0.060 (0.0008 – 0.0024)	—
	2nd	0.020 – 0.060 (0.0008 – 0.0024)	—
Piston pin bore	11.998 – 12.006 (0.4724 – 0.4727)		12.030 (0.4736)
Piston pin O.D.	11.996 – 12.000 (0.4723 – 0.4724)		11.980 (0.4717)

CONROD + CRANKSHAFT

Unit: mm (in)

ITEM	STANDARD	LIMIT
Conrod small end I.D.	16.003 – 16.011 (0.6300 – 0.6304)	16.040 (0.6315)
Conrod deflection	—	3.0 (0.12)
Crank web to web width	40.0 ± 0.1 (1.57 ± 0.004)	—
Crankshaft runout	—	0.05 (0.002)

OIL PUMP

ITEM	SPECIFICATION
Oil pump reduction ratio	7.000 (14 / 2)
CCI pump discharge rate (Full open)	1.02 – 1.26 ml (0.034/0.036 – 0.043/0.044 US/lmp oz) for 6 minutes at 2000 r/min.

CLUTCH

Unit: mm (in)

ITEM	STANDARD		LIMIT
Clutch wheel I.D.	Low	87.00 – 87.15 (3.425 – 3.431)	87.40 (3.441)
	High	105.00 – 105.15 (4.134 – 4.140)	105.50 (4.154)
Clutch shoe O.D.	Low	86.9 – 87.0 (3.42 – 3.43)	No groove at any part
	High	104.7 – 104.8 (4.12 – 4.13)	No groove at any part
Clutch engagement	2500 ± 200 r/min.		—
Clutch lock-up	3700 ± 300 r/min.		—
Clutch spring free length	Low	—	28 (1.10)
	High	—	33 (1.30)

TRANSMISSION

Unit: mm (in)

ITEM	STANDARD		LIMIT
Primary reduction ratio	1.000		—
Final reduction ratio	8.696 (31 / 13 X 62 / 17)		—
Gear ratios	Low	2.137 (62 / 29)	—
	2nd	1.421 (54 / 38)	—
Shift fork thickness	0.05 – 0.10 (0.002 – 0.004)		0.15 (0.006)

DRIVE CHAIN

Unit: mm (in)

ITEM	STANDARD		LIMIT
Drive chain	Type	D.I.D.: 270 H	—
	Links	64	—
	20 pitch length	170.0 (6.69)	173.0 (6.83)

CARBURETOR

Unit: mm (in)

ITEM	SPECIFICATION	
Carburetor type	MIKUNI VM 14 SH	
Bore size	14 (0.6)	
I.D. No.	02420	
Idle r/min.	1500 ± 150 r/min.	
Float height	22.4 ± 1.0 (0.88 ± 0.04)	
Main jet (M. J.)	# 57.5	
Air jet (A. J.)	2.5	
Jet needle (J. N.)	3D13-3	
Needle jet (N. J.)	E-2	
Cut-away (C. A.)	2.0	
Pilot jet (P. J.)	# 15	
Pilot outlet (P. O.)	0.9	
Air screw (A. S.)	1½	
Valve seat (V. S.)	1.2	
Starter jet (G. S.)	35	
Throttle cable play	0.5 – 1.0 (0.02 – 0.04)	

ELECTRICAL

Unit: mm (in)

ITEM	SPECIFICATION		NOTE
Ignition timing	25° ± 2° B.T.D.C. at 4000 r/min.		
Spark plug	Type	NGK BP4HA or NIPPON DENSO W14FP-UL	
	Gap	0.6 - 0.8 (0.024 - 0.031)	
Ignition coil resistance	Primary	B/Y - Ground Approx. 0 - 1 Ω	
	Secondary	Plug cap - Ground Approx. 15 - 17 kΩ	
Magneto coil resistance	Lighting	Y/R - Ground Approx. 0 - 1 Ω	
	Charge	W/R - Ground Approx. 0 - 1 Ω	
	Primary	B/R - R/B Approx. 180 - 220 Ω	
Charging rate	Night	Above 0.7 A at 4000 r/min. Below 3.0 A at 8000 r/min.	
Lighting coil output	Above 5.5 V at 2500 r/min. Below 8.5 V at 8000 r/min.		
Battery	Type designation	6N4-2A	
	Capacity	6V14.4kC(4Ah)/10HR	
	Standard electrolyte S. G.	1.26 at 20°C (68°F)	
Fuse size		10 A	

BRAKE + WHEEL

Unit: mm (in)

ITEM	STANDARD		LIMIT
Front brake lever distance	20 – 30 (0.8 – 1.2)		_____
Rear brake lever distance	20 – 30 (0.8 – 1.2)		_____
Brake drum I.D.	Front	_____	100.7 (3.96)
	Rear	_____	100.7 (3.96)
Brake lining thickness	_____		1.5 (0.06)
Wheel rim runout	Axial	_____	2.0 (0.08)
	Radial	_____	2.0 (0.08)
Wheel axle runout	Front	_____	0.25 (0.010)
Tire size	Front	3.00 – 12 4PR	_____
	Rear	3.00 – 12 4PR	_____
Tire tread depth	Front	_____	1.6 (0.06)
	Rear	_____	1.6 (0.06)

SUSPENSION

Unit: mm (in)

ITEM	STANDARD	LIMIT	NOTE
Engine mounting pivot shaft runout	82 (3.1)	_____	
Swing arm pivot shaft runout	_____	0.6 (0.02)	

FUEL + OIL

ITEM	SPECIFICATION	NOTE
Fuel type	Use only unleaded or low-lead type gasoline of at least 83 – 95 pump octane ($R + \frac{M}{2}$ method) or 89 octane or higher rated by the Research method.	
Fuel tank including reserve	4.5 L (1.2 / 1.0 US/lmp gal)	
reserve	0.2 L (0.21 / 0.18 US/lmp qt)	
Engine oil type	Use SUZUKI CCI SUPER 2-CYCLE MOTOR LUBRICANT or an equivalent good quality synthetic based 2-cycle oil.	
Engine oil tank capacity	1.2 L (1.3 / 1.1 US/lmp qt)	
Transmission oil type	SAE 20W/40	
Transmission oil capacity	Change 800 ml (0.85 / 0.70 US/lmp qt)	
	Overhaul 850 ml (0.90 / 0.75 US/lmp qt)	

TIRE PRESSURE

COLD INFLATION TIRE PRESSURE	NORMAL RIDING		
	SOLO RIDING		
	kPa	kg/cm ²	psi
FRONT	125	1.25	18
REAR	150	1.50	21

WATTAGE

W (CP)

ITEM		SPECIFICATION
Headlight	HI	20
	LO	20
Tail/Brake light		5.3 / 17 (3 / 21)
High beam indicator light		1.7

VIEW OF SUZUKI FZ50 "X"

RIGHT SIDE VIEW



LEFT SIDE VIEW



IGNITION COIL

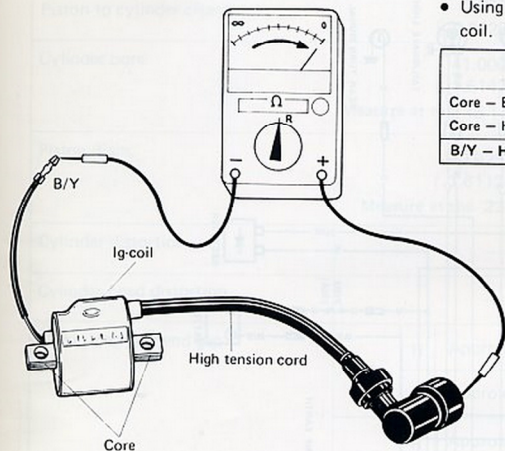

- Using the pocket tester check the ignition coil.

	Resistance	Knob position
Core - B/Y	0 - 1Ω	x 1Ω
Core - High tension	Approx. 4-6kΩ	x kΩ
B/Y - High tension	Approx. 4-6kΩ	x kΩ

TURN SIGNAL LIGHT SWITCH

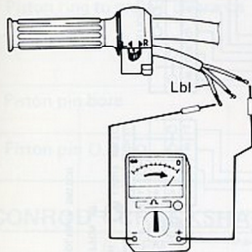

Check the conductivity between the lead terminals on the left handle switch box when the turn signal indicator knob is operated.

If there is conductivity where no connection is shown in the table or no conductivity where a connection is indicated, replace the switch.

	B	Lbl	Lg
Left	○ — ○	○ — ○	○ — ○
Right	○ — ○	○ — ○	○ — ○

WIRING DIAGRAM

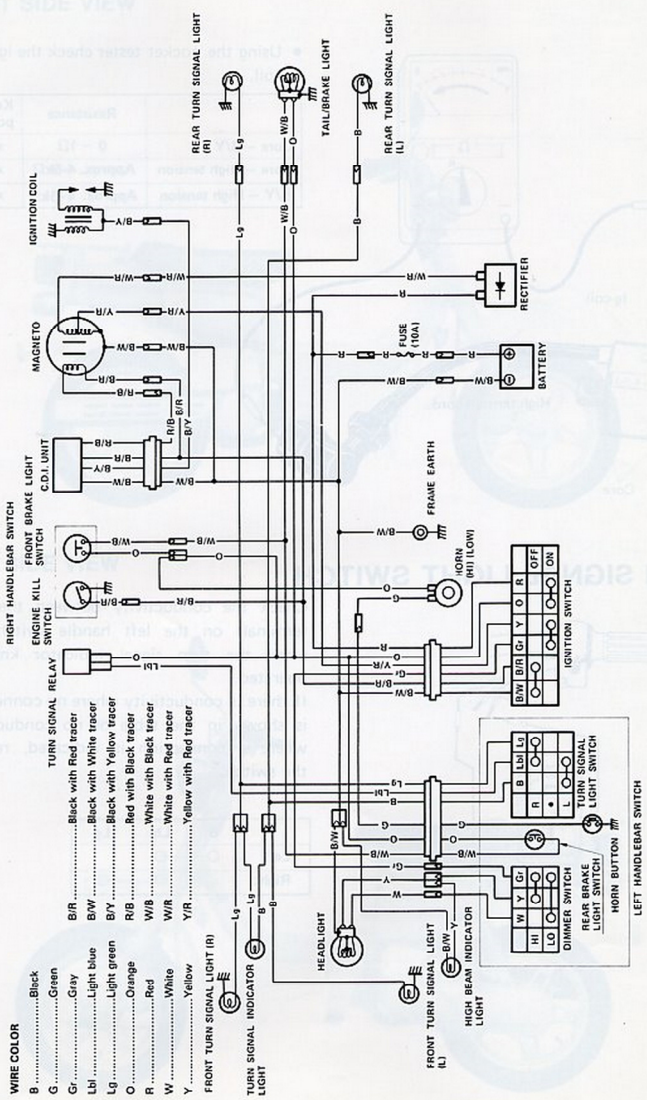

SERVICE DATA

CYLINDER + PISTON + PISTON RING

Unit: mm (in)

ITEM	STANDARD		LIMIT
Piston to cylinder clearance	0.070 – 0.080 (0.0028 – 0.0031)		0.120 (0.0047)
Cylinder bore	41.000 – 41.015 (1.6142 – 1.6148) Measure at the 15 (0.6) from top surface.		41.060 (1.6165)
Piston diam.	40.925 – 40.940 (1.6112 – 1.6118) Measure at the 23 (0.9) from skirt end.		40.880 (1.6094)
Cylinder distortion	—		0.05 (0.002)
Cylinder head distortion	—		0.05 (0.002)
Piston ring free end gap	1st	R Approx. 4.5 (0.18)	3.6 (0.14)
		T Approx. 5.0 (0.20)	4.0 (0.16)
	2nd	R Approx. 4.5 (0.18)	3.6 (0.14)
		T Approx. 5.0 (0.20)	4.0 (0.16)
Piston ring end gap	0.10 – 0.25 (0.004 – 0.010)		0.75 (0.030)
Piston ring to groove clearance	1st	0.020 – 0.060 (0.0008 – 0.0024)	—
	2nd	0.020 – 0.060 (0.0008 – 0.0024)	—
Piston pin bore	11.998 – 12.006 (0.4724 – 0.4727)		12.030 (0.4736)
Piston pin O.D.	11.996 – 12.000 (0.4723 – 0.4724)		11.980 (0.4717)

CONROD + CRANKSHAFT

Unit: mm (in)

ITEM	STANDARD	LIMIT
Conrod small end I.D.	16.003 – 16.011 (0.6300 – 0.6304)	16.040 (0.6315)
Conrod deflection	—	3.0 (0.12)
Crank web to web width	40.0 ± 0.1 (1.57 ± 0.004)	—
Crankshaft runout	—	0.05 (0.002)

OIL PUMP

ITEM	SPECIFICATION
Oil pump reduction ratio	7.000 (14 / 2)
CCI pump discharge rate (Full open)	1.02 – 1.26 ml (0.034/0.036 – 0.043/0.044 US/lmp oz) for 6 minutes at 2000 r/min.

CLUTCH

Unit: mm (in)

ITEM	STANDARD		LIMIT
Clutch wheel I.D.	Low	87.00 – 87.15 (3.425 – 3.431)	87.40 (3.441)
	High	105.00 – 105.15 (4.134 – 4.140)	105.50 (4.154)
Clutch shoe O.D.	Low	86.9 – 87.0 (3.42 – 3.43)	No groove at any part
	High	104.7 – 104.8 (4.12 – 4.13)	No groove at any part
Clutch engagement	2500 ± 200 r/min.		—
Clutch lock-up	3700 ± 300 r/min.		—
Clutch spring free length	Low	—	28 (1.10)
	High	—	33 (1.30)

TRANSMISSION

Unit: mm (in)

ITEM	STANDARD		LIMIT
Primary reduction ratio	1.000		—
Final reduction ratio	8.696 (31 / 13 X 62 / 17)		—
Gear ratios	Low	2.137 (62 / 29)	—
	2nd	1.421 (54 / 38)	—
Shift fork thickness	0.05 – 0.10 (0.002 – 0.004)		0.15 (0.006)

DRIVE CHAIN

Unit: mm (in)

ITEM	STANDARD		LIMIT
Drive chain	Type	D.I.D.: 270 H	—
	Links	64	—
	20 pitch length	170.0 (6.69)	173.0 (6.83)

CARBURETOR

Unit: mm (in)

ITEM	SPECIFICATION
Carburetor type	MIKUNI VM 14 SH
Bore size	14 (0.6)
I.D. No.	02421
Idle r/min.	1500 ± 150 r/min.
Float height	22.4 ± 1.0 (0.88 ± 0.04)
Main jet (M. J.)	# 57.5
Air jet (A. J.)	2.5
Jet needle (J. N.)	3D13-3
Needle jet (N. J.)	E-2
Cut-away (C. A.)	2.0
Pilot jet (P. J.)	# 15
Pilot outlet (P. O.)	0.9
Air screw (A. S.)	1%
Valve seat (V. S.)	1.5
Starter jet (G. S.)	35
Throttle cable play	0.5 - 1.0 (0.02 - 0.04)

ELECTRICAL

Unit: mm (in)

ITEM	SPECIFICATION		NOTE
Ignition timing	25° ± 2° B.T.D.C. at 4000 r/min.		
Spark plug	Type	NGK BP4HA or NIPPON DENSO W14FP-UL	
	Gap	0.6 - 0.8 (0.024 - 0.031)	
Ignition coil resistance	Primary	B/Y - Ground, Approx. 0 - 1 Ω	
	Secondary	Plug cap - Ground Approx. 4 - 6 kΩ	
Magneto coil resistance	Lighting	B/W - Y Approx. 0.4 Ω	
	Charge	B/W - W/R Approx. 0.75 Ω	
	Primary	B/R - R/B Approx. 230 Ω	
Charging rate	Night	Above 0.7 A at 4000 r/min. Below 3.0 A at 8000 r/min.	
Lighting coil output	Above 5.5 V at 2500 r/min. Below 8.5 V at 8000 r/min.		
Battery	Type designation	6N4-2A	
	Capacity	6V14.4kC(4Ah)/10HR	
	Standard electrolyte S. G.	1.26 at 20°C (68°F)	
Fuse size	10 A		

BRAKE + WHEEL

Unit: mm (in)

ITEM	STANDARD		LIMIT
Front brake lever distance	20 – 30 (0.8 – 1.2)		—
Rear brake lever distance	20 – 30 (0.8 – 1.2)		—
Brake drum I.D.	Front	—	100.7 (3.96)
	Rear	—	100.7 (3.96)
Brake lining thickness	—		1.5 (0.06)
Wheel rim runout	Axial	—	2.0 (0.08)
	Radial	—	2.0 (0.08)
Wheel axle runout	Front	—	0.25 (0.010)
Tire size	Front	3.00 – 12 4PR	—
	Rear	3.00 – 12 4PR	—
Tire tread depth	Front	—	1.6 (0.06)
	Rear	—	1.6 (0.06)

SUSPENSION

Unit: mm (in)

ITEM	STANDARD	LIMIT	NOTE
Engine mounting pivot shaft runout	82 (3.1)	—	
Swing arm pivot shaft runout	—	0.6 (0.02)	

FUEL + OIL

ITEM	SPECIFICATION	NOTE
Fuel type	Use only unleaded or low-lead type gasoline of at least 83 – 95 pump octane ($\frac{R+M}{2}$ method) or 89 octane or higher rated by the Research method.	
Fuel tank including reserve	4.5 L (1.2 / 1.0 US/Imp gal)	
reserve	0.2 L (0.21 / 0.18 US/Imp qt)	
Engine oil type	Use SUZUKI CCI SUPER 2-CYCLE MOTOR LUBRICANT or an equivalent good quality synthetic based 2-cycle oil.	
Engine oil tank capacity	1.2 L (1.3 / 1.1 US/Imp qt)	
Transmission oil type	SAE 20W/40	
Transmission oil capacity	Change 800 ml (0.85 / 0.70 US/Imp qt)	
	Overhaul 850 ml (0.90 / 0.75 US/Imp qt)	

TIRE PRESSURE

COLD INFLATION TIRE PRESSURE	NORMAL RIDING		
	SOLO RIDING		
	kPa	kg/cm ²	psi
FRONT	125	1.25	18
REAR	150	1.50	21

WATTAGE

ITEM		SPECIFICATION	W (CP)
Headlight	HI	20	
	LO	20	
Tail/Brake light		5.3 / 17 (3 / 21)	
Turn signal light		17	
Turn signal indicator light		3	
High beam indicator light		1.7	

Prepared by

SUZUKI MOTOR CO., LTD.

Service Department
Overseas Operations Division

December, 1980

Manual No. 99000-85057-0E3 (英) SUPPL.
Printed in Japan

SUZUKI MOTOR CO., LTD.

T. X

Suzuki FZ50 Supplementary Service Manual

This manual was provided by Donald Small